

**INDEX**

<u>Description</u>	<u>Page</u>
A Series, C Series and D Series ( <i>Data Page</i> )	4
A1-A8 Pump, Bi-Directional	5
A21-A27 Pump Bi-Directional	7
C1-C8 Pump, Bi-Directional	9
C21-C27 Pump, Bi-Directional	11
C41-C49 Pump, Bi-Directional	13
D1-D8 Pump, Bi-Directional	15
D21-D27 Pump, Bi-Directional	17
D41-D49 Pump, Bi-Directional	19
L Series 2 Stage HI-LOW Pumps ( <i>Data Page</i> )	21
L6 and L8 Series 2 Stage HI-LOW Pumps	23
L24 and L26 Series 2 Stage HI-LOW Pumps	25

**WARNING:** The specifications/application data shown in our catalogs and data sheets are intended only as a general guide for the product described (herein). Any specific application should not be undertaken without independent study, evaluation, and testing for suitability.

**A Series, C Series, and D Series Fixed Clearance Pumps**

**A Series**  
Tang Drive



4F17 Mtg.  
Shown

**C Series**  
Extended Shaft



SAE A Mtg.  
Shown

**D Series**  
Ext. Shaft  
w/Outboard Bearing

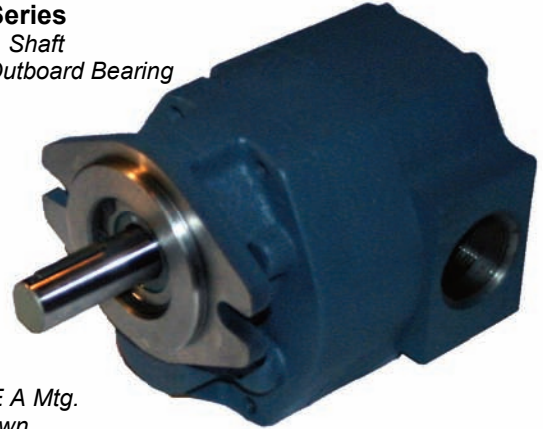

SAE A Mtg.  
Shown

Delta's fixed clearance gear pumps are offered in three series A, C, and D with flows ranging from 0.5 GPM to 35 GPM. Delta pumps are designed to provide greater torque efficiencies – especially at high speeds. Numerous shaft, bearing, mounting and seal options are available. Each model is designed to operate as either a single rotation or bi-rotational pump, depending on the application.

A Series, C Series, and D Series hydraulic pumps are designed with long term performance in mind, including: high-strength cast iron bodies, hardened alloy gears and shafts, bronze bearings, and Buna-N sealing members. Integral check valves permit bi-directional rotation to simplify plumbing. The D Series pumps incorporate drive shaft thrust ball bearings to facilitate thrust and radial shaft loads.

Because of their long proven construction, these pumps are found in every type of mobile and industrial applications. They can be expected to perform for the life expectancy of the equipment on which installed.

**Installation Notes**

On models A1-A8, C1-C8, and D1-D8 be especially careful since these units require that the mounting bolts are installed to complete the assembly. The two shipping bolts are not sufficient to make the assembly intact and care should be exercised while handling in that condition. Bolt torque requirements are 13 to 17 ft-lbs.

	MODEL	GPM AT 1750 RPM	DISPLACEMENT		SLIP GPM PER 100 PSI	MAX. PSI		MAX. RPM	Page
			GAL./REV	IN <sup>3</sup> /REV		INT. DUTY	CONT. DUTY		
TANG DRIVE	A1	0.49	0.00028	0.065	0.015	2500	1500	5000	5
	A2	0.82	0.00047	0.108	0.017	2500	1500	5000	5
	A4	1.41	0.00081	0.187	0.020	2250	1500	4000	5
	A6	2.39	0.00137	0.316	0.025	1650	950	3600	5
	A8	3.53	0.00202	0.468	0.030	1250	650	2500	5
	A21	3.10	0.00178	0.411	0.040	2000	1500	5000	7
	A23	5.30	0.00304	0.702	0.045	1600	1200	4000	7
	A25	7.42	0.00425	0.981	0.055	1000	850	3500	7
A27	11.10	0.00633	1.460	0.075	750	550	2400	7	
EXTENDED SHAFT	C1	0.49	0.00028	0.065	0.015	2500	1500	5000	9
	C2	0.82	0.00047	0.108	0.017	2500	1500	5000	9
	C4	1.41	0.00081	0.187	0.020	2500	1500	4000	9
	C6	2.39	0.00137	0.316	0.025	1850	1100	3000	9
	C8	3.53	0.00202	0.468	0.030	1500	750	1800	9
	C21	3.10	0.00178	0.411	0.040	2500	1500	5000	11
	C23	5.30	0.00304	0.702	0.045	2350	1500	4000	11
	C25	7.42	0.00425	0.981	0.055	1500	1500	3000	11
	C27	11.10	0.00633	1.460	0.075	1200	1100	1800	11
	C41	11.90	0.0068	1.570	0.070	2500	1500	4000	13
EXT. SHAFT W/OUTBOARD BEARING	D1	0.49	0.00028	0.065	0.015	2500	1500	5000	15
	D2	0.82	0.00047	0.108	0.017	2500	1500	5000	15
	D4	1.41	0.00081	0.187	0.020	2500	1500	4000	15
	D6	2.39	0.00137	0.316	0.025	1850	1100	3000	15
	D8	3.53	0.00202	0.468	0.030	1500	750	1800	15
	D21	3.10	0.00178	0.411	0.040	2500	1500	5000	17
	D23	5.30	0.00304	0.702	0.045	2350	1500	4000	17
	D25	7.42	0.00425	0.981	0.055	1500	1500	3000	17
	D27	11.10	0.00633	1.460	0.075	1200	1100	1800	17
D41	11.90	0.0068	1.570	0.070	2500	1500	4000	19	
D43	17.80	0.0102	2.350	0.090	2450	1500	3000	19	
D45	23.10	0.0132	3.040	0.110	1850	1500	2300	19	
D47	29.50	0.0169	3.900	0.140	1500	1200	1800	19	
D49	33.60	0.0192	4.430	0.180	1000	700	1800	19	

**WARNING:** The specifications/application data shown in our catalogs and data sheets are intended only as a general guide for the product described (herein). Any specific application should not be undertaken without independent study, evaluation, and testing for suitability.

**A1-A8 Pump, Bi-Directional**

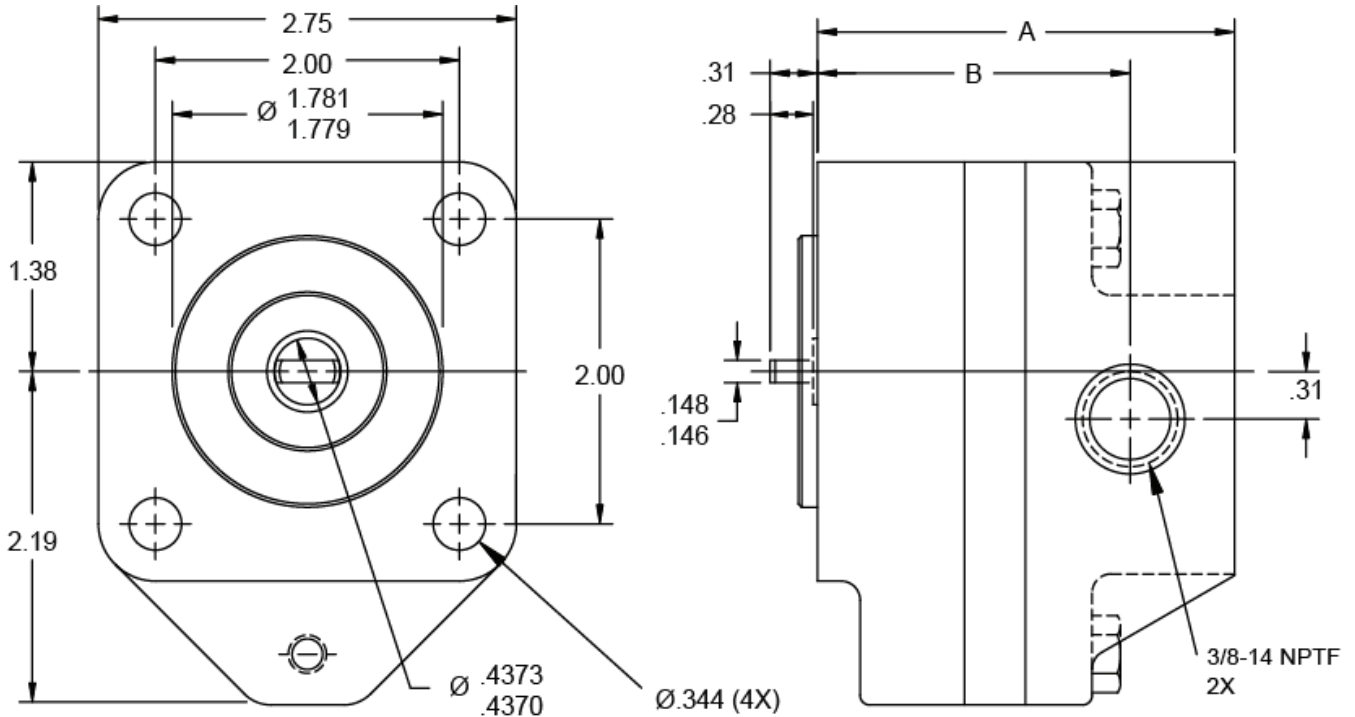

For best performance: Inlet pressure should not exceed 10 PSI and vacuum should be limited to 8 inches of mercury at the pump. Inlet lines always must be large, straight, short and absolutely leak-proof, even more so as RPM increases. Suggested maximum inlet velocity is 6 feet per second.

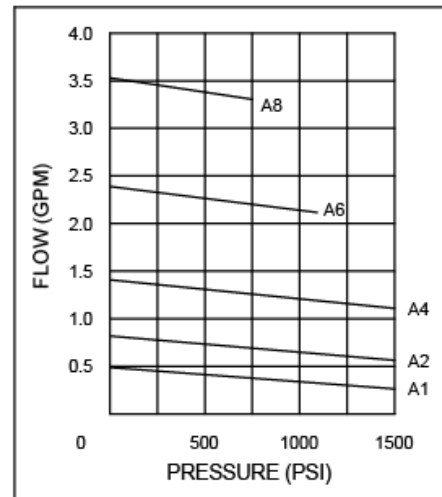
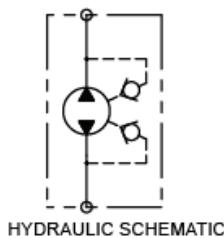

MODEL	GPM AT 1750 RPM	0 PSI DISP. GAL./REV.	DISP. CU. IN./REV.	SLIP GPM PER 100 PSI	MAX. RPM	PRESS. MAX. CONTINUOUS	A	B
A1	0.49	0.00028	0.065	0.015	5000	1500	2.48	1.79
A2	0.82	0.00047	0.108	0.017	5000	1500	2.57	1.88
A4	1.41	0.00081	0.187	0.020	4000	1500	2.74	2.05
A6	2.39	0.00137	0.316	0.025	3600	1100	3.02	2.33
A8	3.53	0.00202	0.468	0.030	2500	750	3.34	2.65

**WARNING:** The specifications/application data shown in our catalogs and data sheets are intended only as a general guide for the product described (herein). Any specific application should not be undertaken without independent study, evaluation, and testing for suitability.

A1-A8 Pump, Bi-Directional

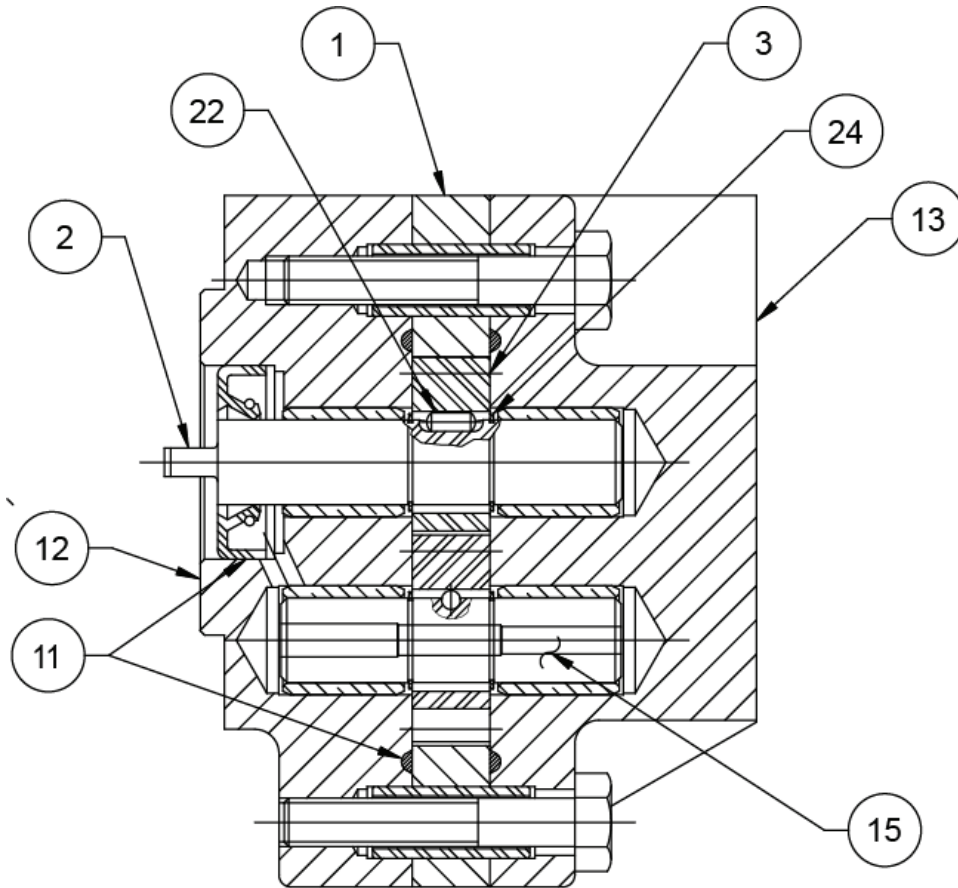

SECTION A-A

ITEM #	DESCRIPTION	QTY.
1	GEAR CASE	1
2	DRIVE SHAFT	1
3	GEAR	1
11	SEAL KIT	1
12	DRIVE PLATE ASS'Y	1
13	END PLATE ASS'Y	1
15	IDLER SHAFT ASS'Y	1
22	GEAR PIN	1
24	RETAINING RING	2

**WARNING:** The specifications/application data shown in our catalogs and data sheets are intended only as a general guide for the product described (herein). Any specific application should not be undertaken without independent study, evaluation, and testing for suitability.



**A21-A27 Pump, Bi-Directional**

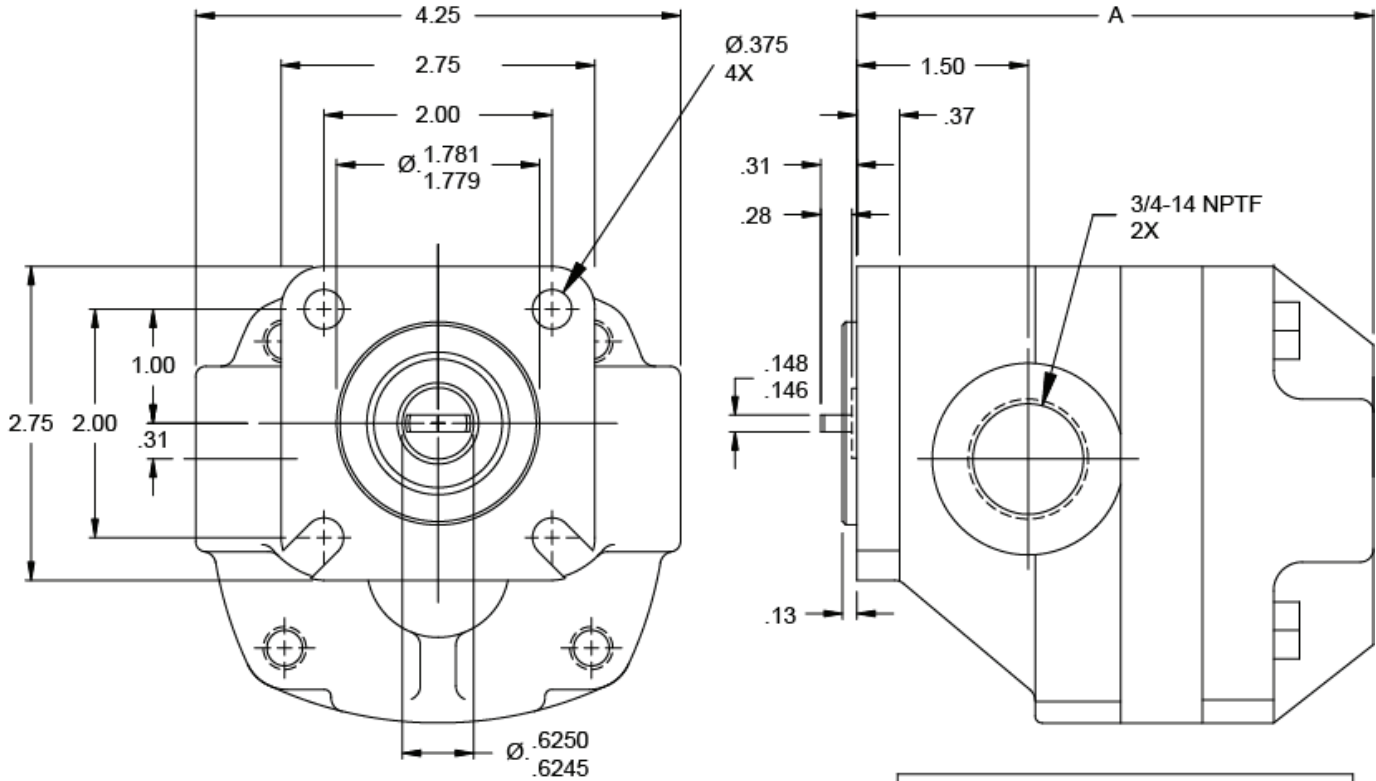

For best performance: Inlet pressure should not exceed 10 PSI and vacuum should be limited to 8 inches of mercury at the pump. Inlet lines always must be large, straight, short and absolutely leak-proof, even more so as RPM increases. Suggested maximum inlet velocity is 6 feet per second.

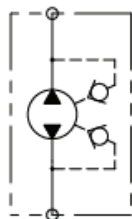
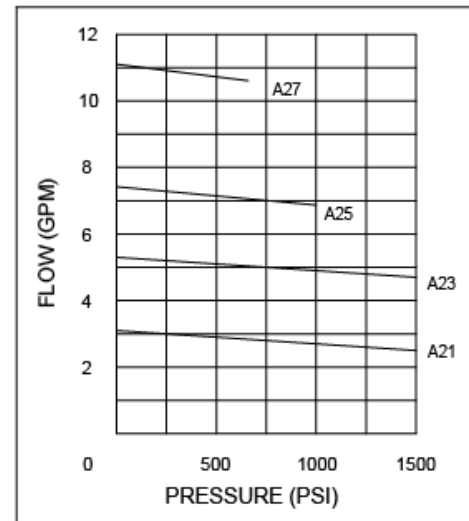

HYDRAULIC SCHEMATIC

MODEL	GPM AT 1750 RPM	0 PSI DISP. GAL./REV.	DISP. CU. IN./REV.	SLIP GPM PER 100 PSI	MAX. RPM	PRESS. MAX. CONTINUOUS	A
A21	3.10	0.00178	0.411	0.040	5000	1500	4.24
A23	5.30	0.00304	0.702	0.045	4000	1500	4.54
A25	7.42	0.00425	0.981	0.055	3500	1000	4.76
A27	11.10	0.00633	1.460	0.075	2400	700	5.32

**WARNING:** The specifications/application data shown in our catalogs and data sheets are intended only as a general guide for the product described (herein). Any specific application should not be undertaken without independent study, evaluation, and testing for suitability.

A21-A27 Pump, Bi-Directional

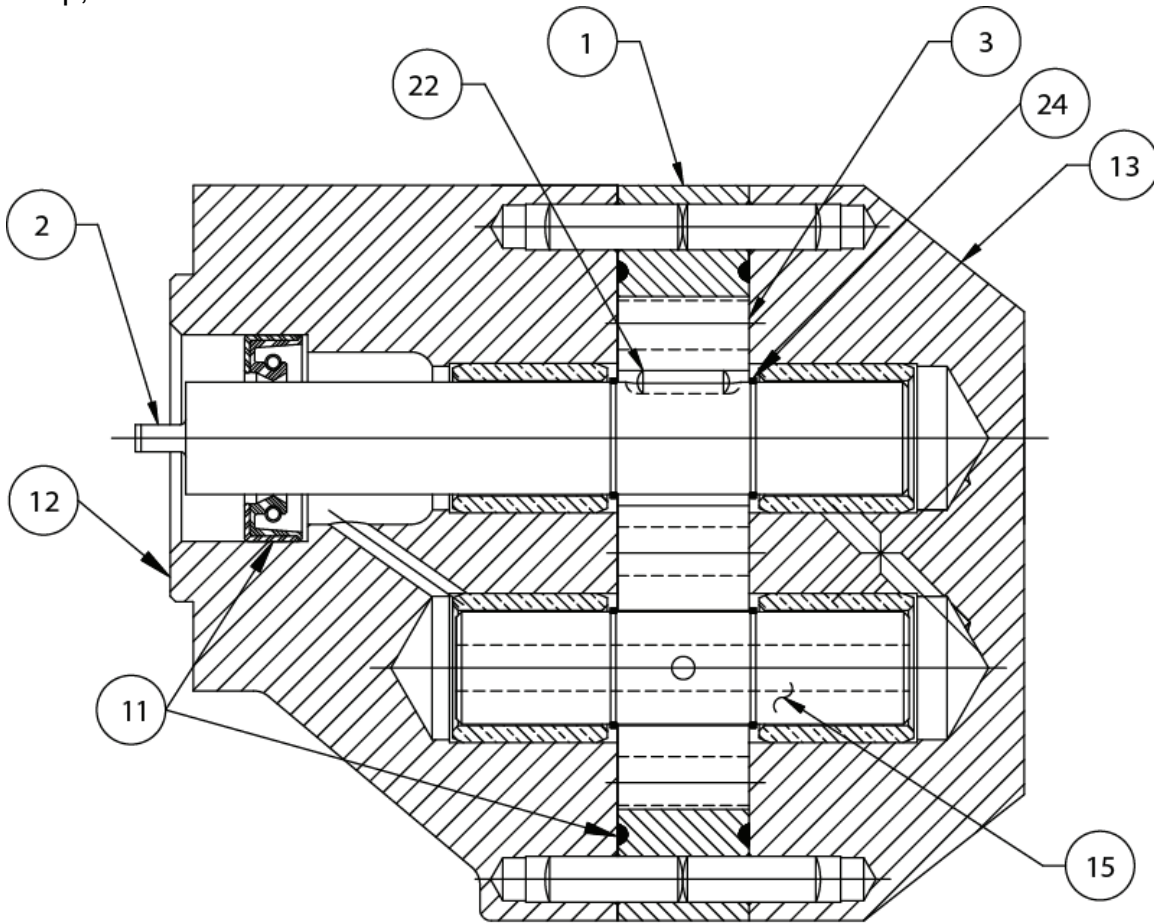

SECTION A-A

ITEM #	DESCRIPTION	QTY.
1	GEAR CASE	1
2	DRIVE SHAFT	1
3	GEAR	1
11	SEAL KIT	1
12	DRIVE PLATE ASS'Y	1
13	END PLATE ASS'Y	1
15	IDLER SHAFT ASS'Y	1
22	GEAR PIN	1
24	RETAINING RING	2

**WARNING:** The specifications/application data shown in our catalogs and data sheets are intended only as a general guide for the product described (herein). Any specific application should not be undertaken without independent study, evaluation, and testing for suitability.

**C1-C8 Pump, Bi-Directional**

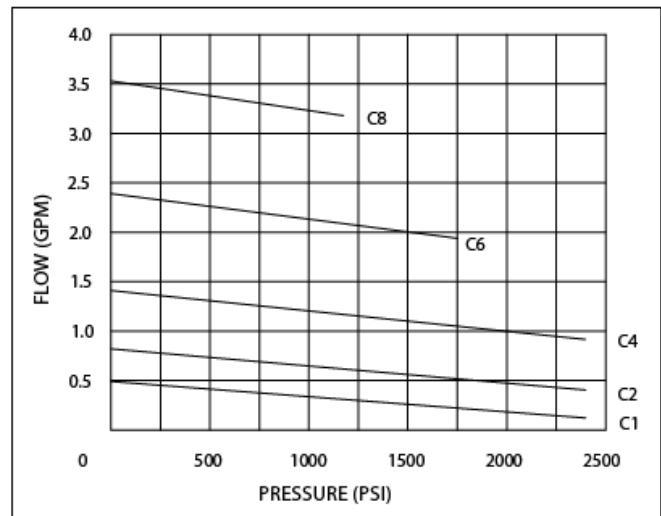
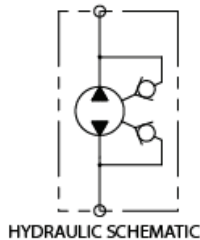
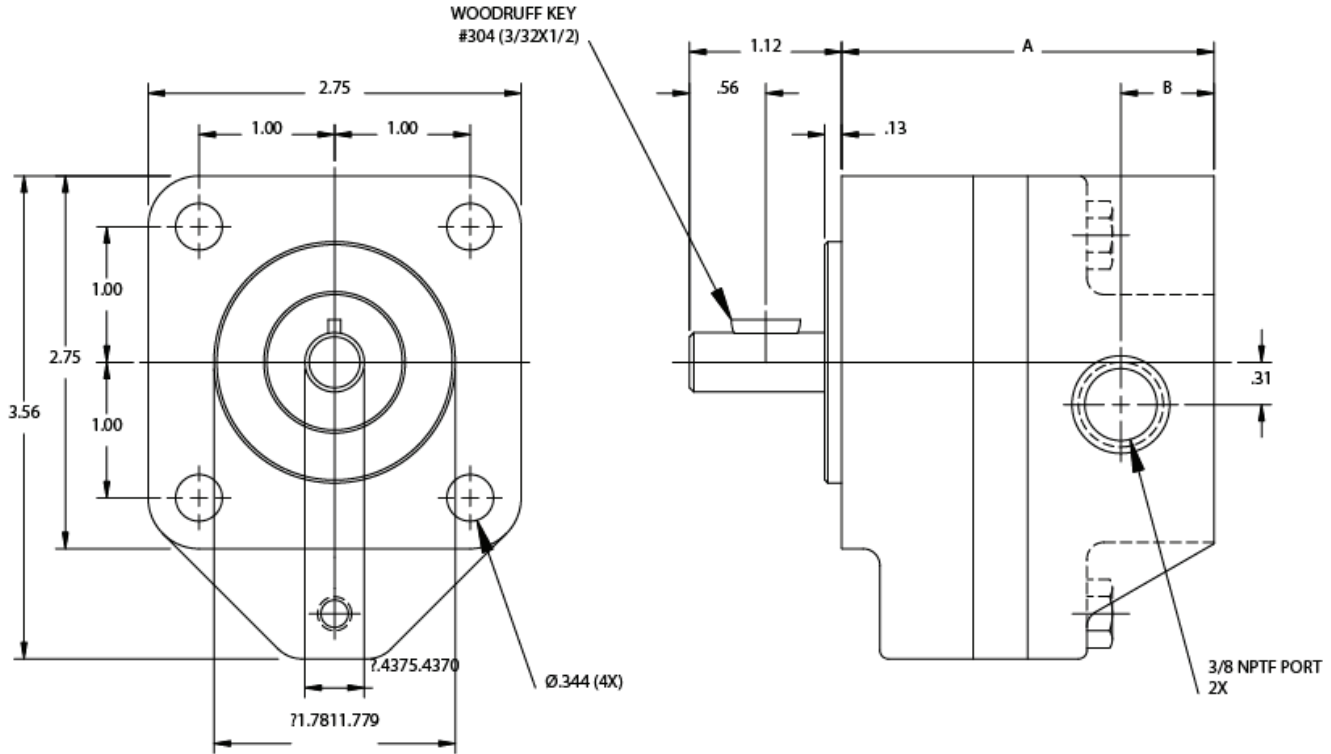

MODEL	GPM AT 1750 RPM	0 PSI DISP. GAL./REV.	DISP. CU. IN./REV.	SLIP GPM PER 100 PSI	MAX. PUMP PRESSURE INTERMITTENT DUTY	MAX. PUMP PRESSURE CONTINUOUS DUTY	SPEED MAX. RPM	A	B
C1	0.49	0.00028	0.065	0.015	2400	1500	5000	2.48	0.69
C2	0.82	0.00047	0.108	0.017	2400	1500	5000	2.57	0.69
C4	1.41	0.00081	0.187	0.020	2400	1500	4000	2.74	0.69
C6	2.39	0.00137	0.316	0.025	1750	1100	3000	3.02	0.69
C8	3.53	0.00202	0.468	0.030	1200	750	1800	3.34	0.69

**WARNING:** The specifications/application data shown in our catalogs and data sheets are intended only as a general guide for the product described (herein). Any specific application should not be undertaken without independent study, evaluation, and testing for suitability.

C1-C8 Pump, Bi-Directional

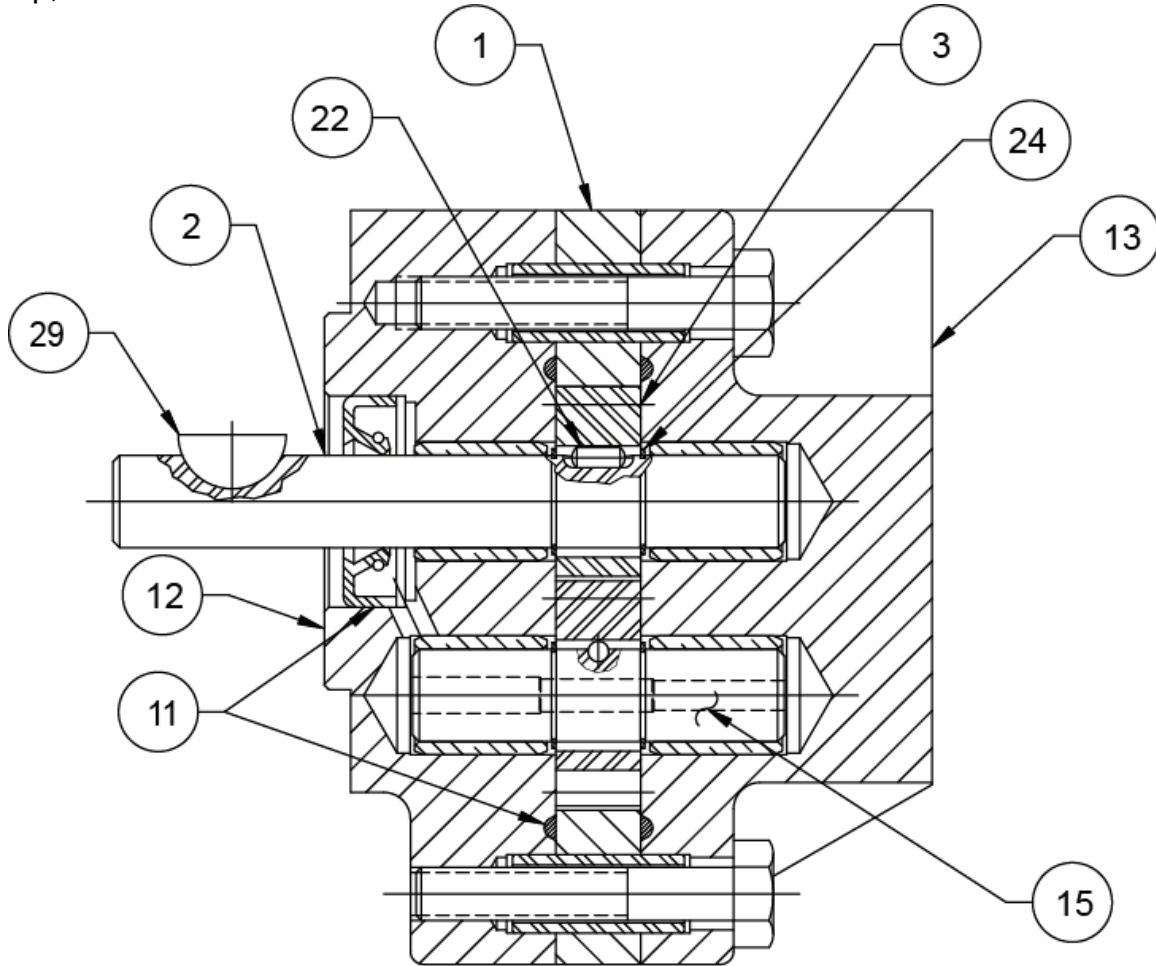

SECTION A-A

ITEM #	DESCRIPTION	QTY.
1	GEAR CASE	1
2	DRIVE SHAFT	1
3	GEAR	1
11	SEAL KIT	1
12	DRIVE PLATE ASS'Y	1
13	END PLATE ASS'Y	1
15	IDLER SHAFT ASS'Y	1
22	GEAR PIN	1
24	RETAINING RING	2
29	DRIVE KEY	1

**WARNING:** The specifications/application data shown in our catalogs and data sheets are intended only as a general guide for the product described (herein). Any specific application should not be undertaken without independent study, evaluation, and testing for suitability.



**C21-C27 Pump, Bi-Directional**

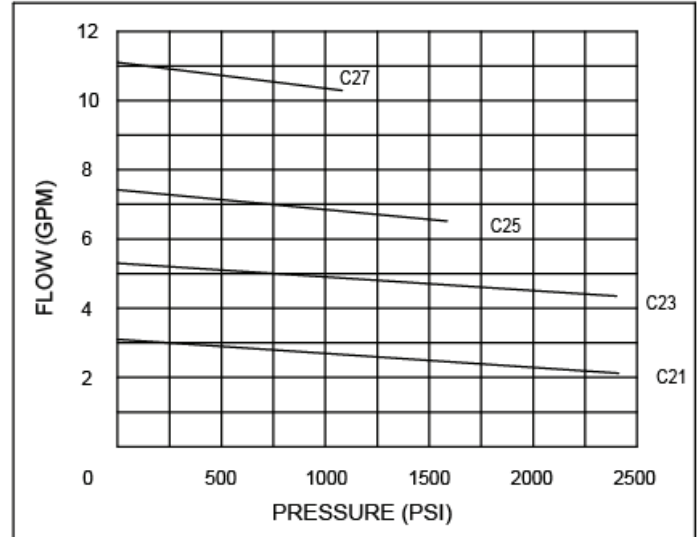
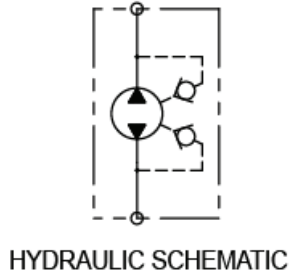
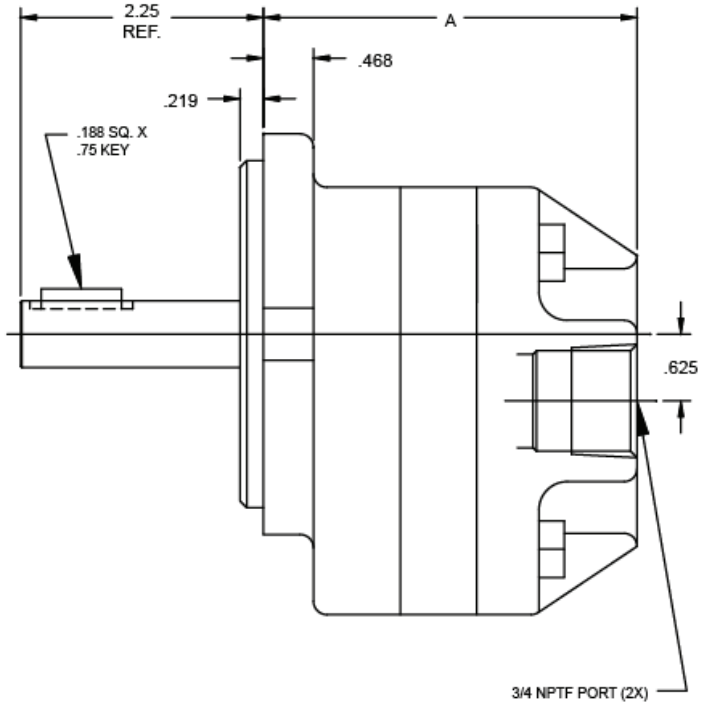
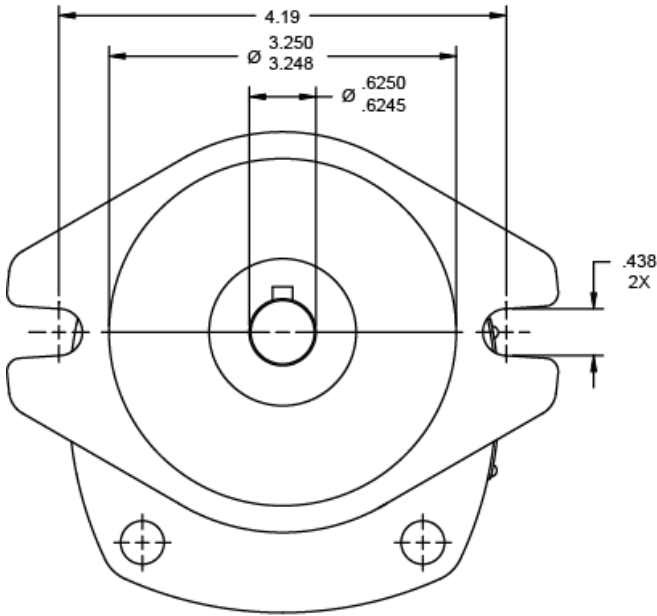

MODEL	GPM AT 1750 RPM	0 PSI DISP. GAL./REV.	DISP. CU. IN./REV.	SLIP GPM PER 100 PSI	MAX. PUMP PRESSURE INTERMITTENT DUTY	MAX. PUMP PRESSURE CONTINUOUS DUTY	SPEED MAX. RPM	A
C21	3.10	0.00178	0.411	0.040	2400	1500	5000	3.21
C23	5.30	0.00304	0.702	0.045	2400	1500	4000	3.56
C25	7.42	0.00425	0.981	0.055	1600	1000	3000	3.78
C27	11.10	0.00633	1.460	0.075	1100	700	1800	4.21

**WARNING:** The specifications/application data shown in our catalogs and data sheets are intended only as a general guide for the product described (herein). Any specific application should not be undertaken without independent study, evaluation, and testing for suitability.

C21-C27 Pump, Bi-Directional

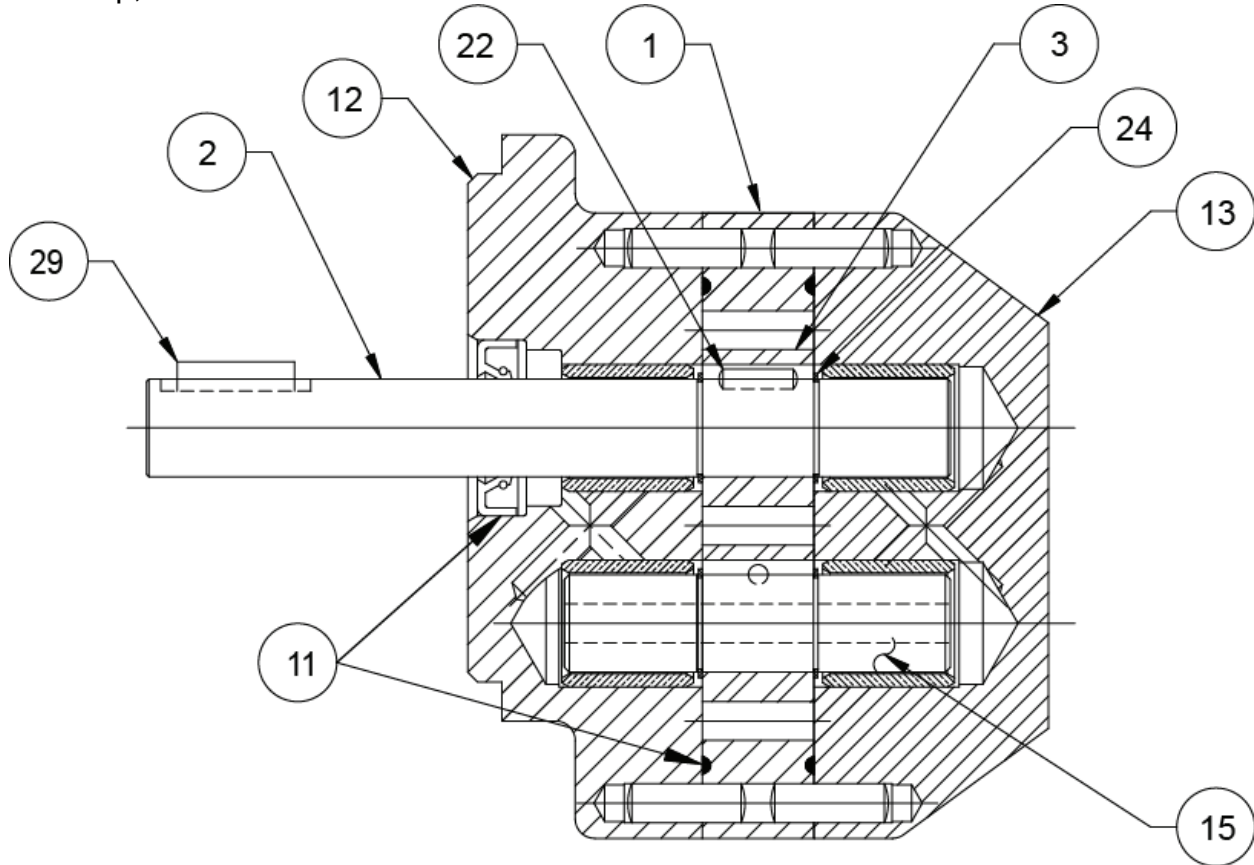

SECTION A-A

ITEM #	DESCRIPTION	QTY.
1	GEAR CASE	1
2	DRIVE SHAFT	1
3	GEAR	1
11	SEAL KIT	1
12	DRIVE PLATE ASS'Y	1
13	END PLATE ASS'Y	1
15	IDLER SHAFT ASS'Y	1
22	GEAR PIN	1
24	RETAINING RING	2
29	DRIVE KEY	1

**WARNING:** The specifications/application data shown in our catalogs and data sheets are intended only as a general guide for the product described (herein). Any specific application should not be undertaken without independent study, evaluation, and testing for suitability.

**C41-C49 Pump, Bi-Directional**

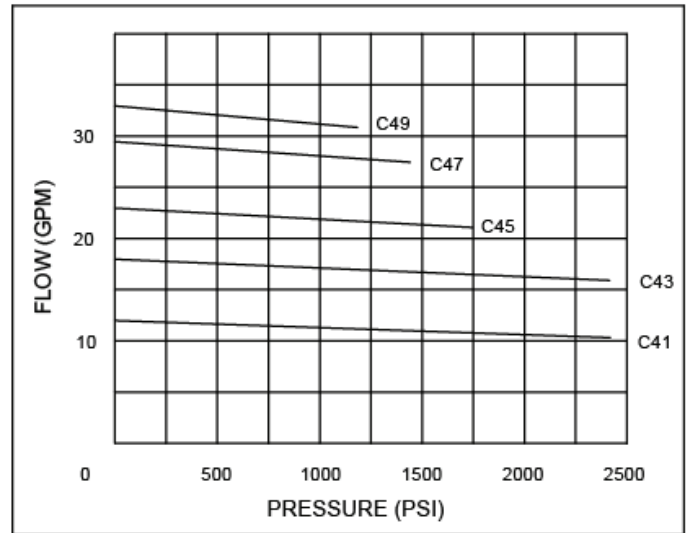
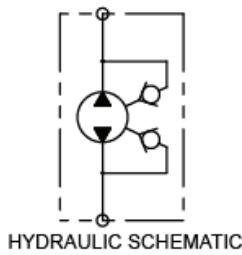
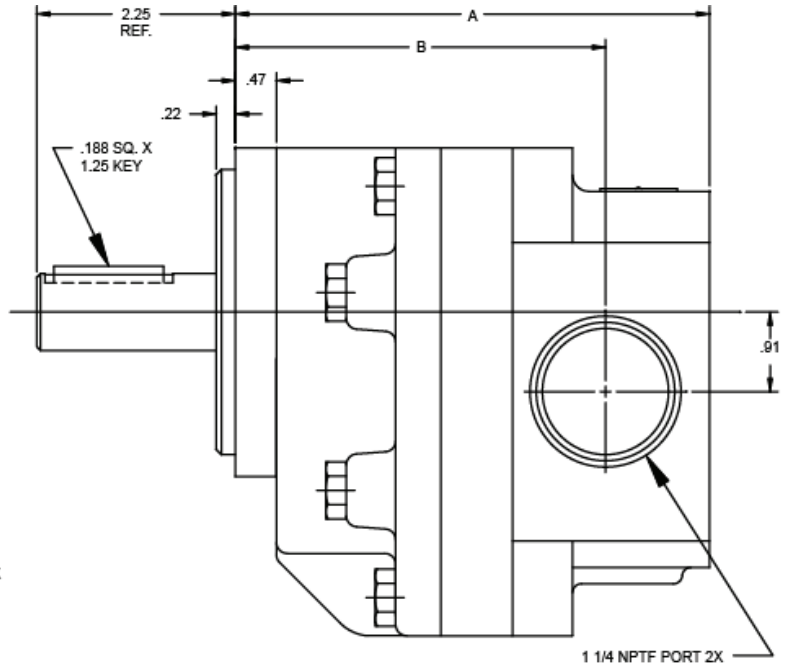
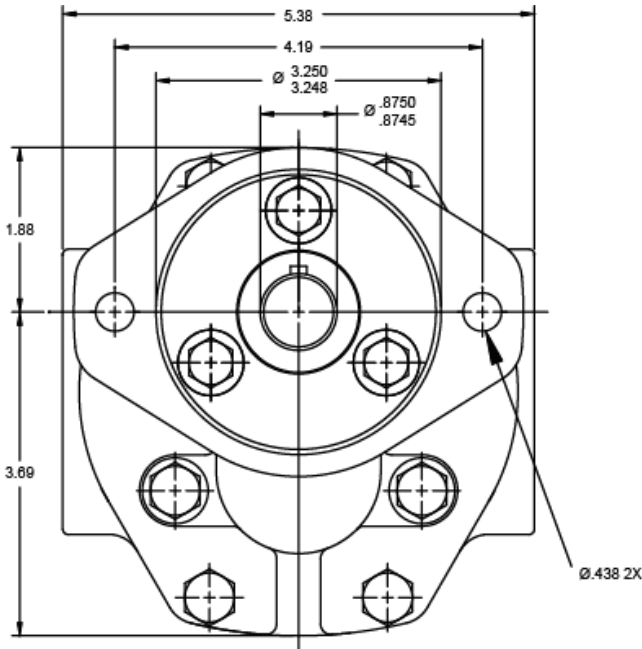

MODEL	GPM AT 1750 RPM	0 PSI DISP. GAL./REV.	DISP. CU. IN./REV.	SLIP GPM PER 100 PSI	MAX. PUMP PRESSURE INTERMITTENT DUTY	MAX. PUMP PRESSURE CONTINUOUS DUTY	SPEED MAX. RPM	A	B
C41	11.90	0.0068	1.570	0.070	2400	1500	4000	5.41	4.22
C43	17.80	0.0102	2.350	0.090	2400	1500	3000	5.72	4.59
C45	23.10	0.0132	3.040	0.110	1750	1100	2300	6.06	4.94
C47	29.50	0.0169	3.900	0.140	1450	900	1800	6.47	5.41
C49	33.60	0.0192	4.430	0.180	1200	750	1800	6.72	5.59

**WARNING:** The specifications/application data shown in our catalogs and data sheets are intended only as a general guide for the product described (herein). Any specific application should not be undertaken without independent study, evaluation, and testing for suitability.

Phone: (815) 397-6628

Fax: (815) 397-2526

E-mail: [delta@delta-power.com](mailto:delta@delta-power.com)

C41-C49 Pump, Bi-Directional

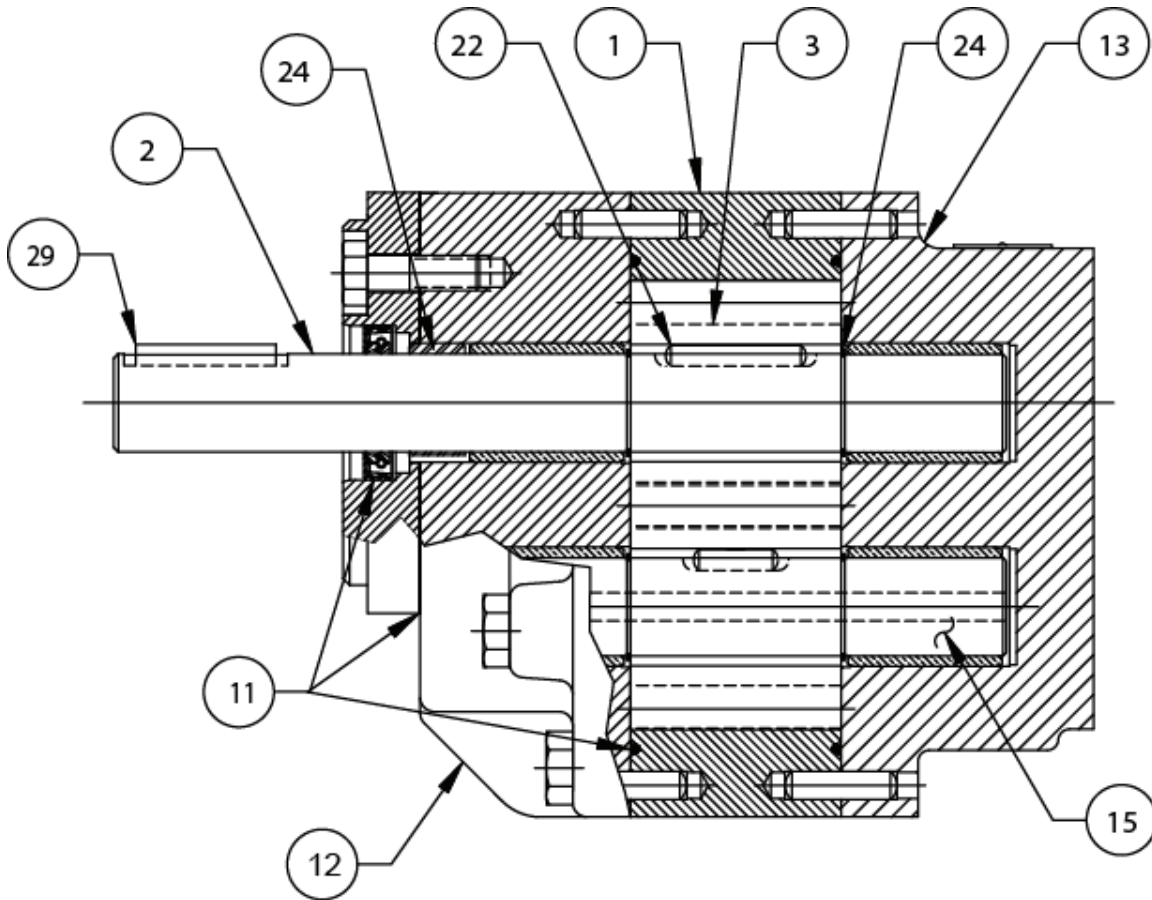

SECTION A-A

ITEM #	DESCRIPTION	QTY.
1	GEAR CASE	1
2	DRIVE SHAFT	1
3	GEAR	1
11	SEAL KIT	1
12	DRIVE PLATE ASS'Y	1
13	END PLATE ASS'Y	1
15	IDLER SHAFT ASS'Y	1
22	GEAR PIN	1
24	RETAINING RING	2
29	DRIVE KEY	1

**WARNING:** The specifications/application data shown in our catalogs and data sheets are intended only as a general guide for the product described (herein). Any specific application should not be undertaken without independent study, evaluation, and testing for suitability.

**D1-D8 Pump, Bi-Directional**

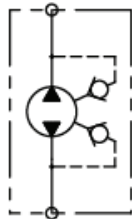
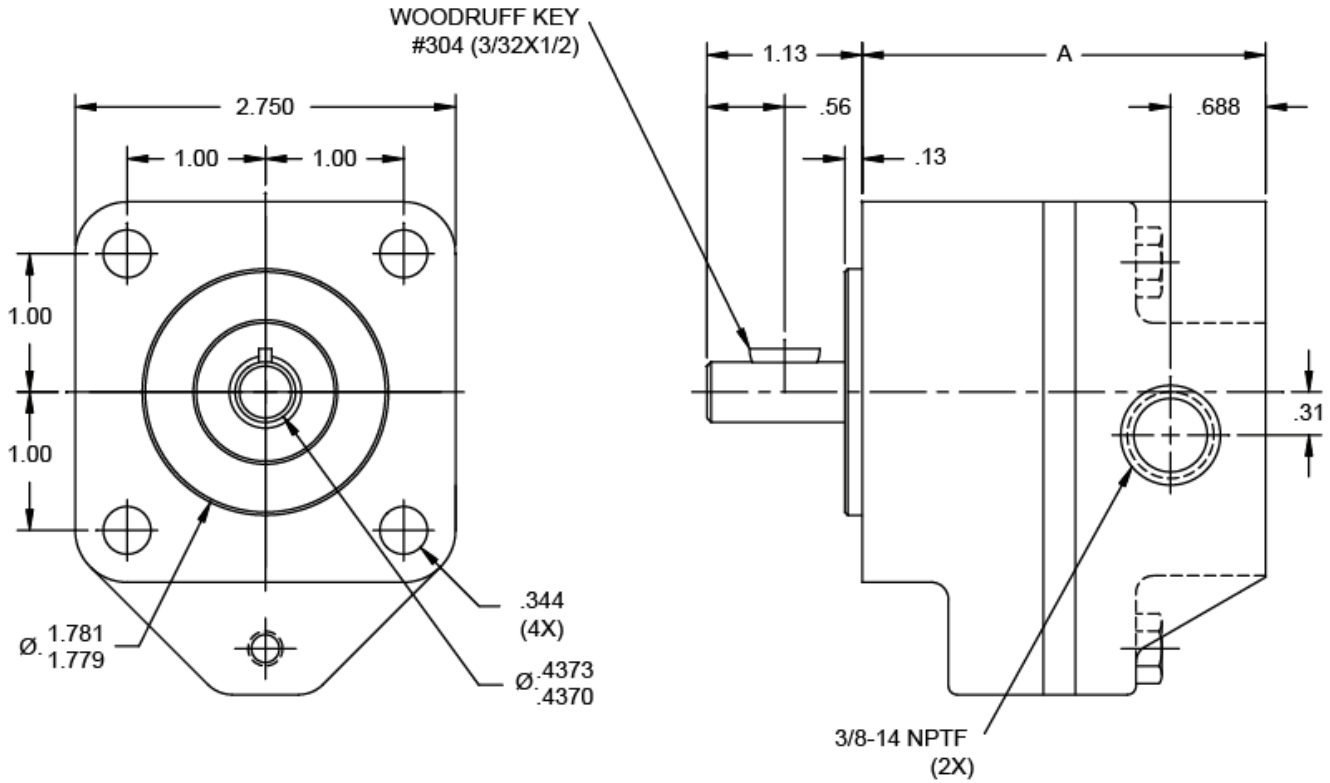

HYDRAULIC SCHEMATIC

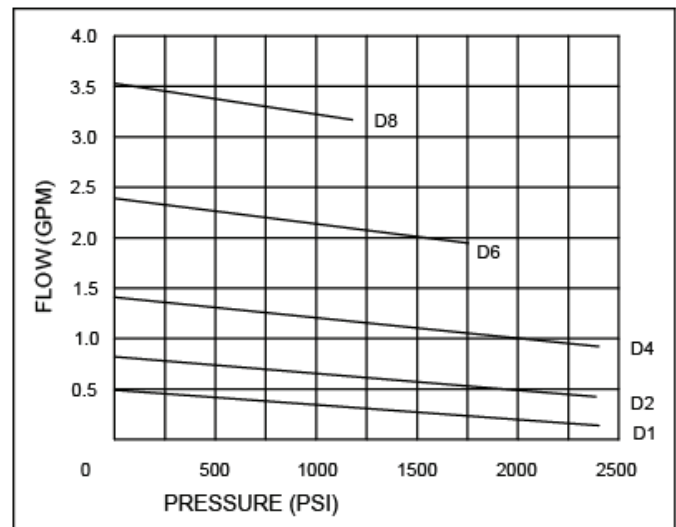

MODEL	GPM AT 1750 RPM	0 PSI DISP. GAL./REV.	DISP. CU. IN./REV.	SLIP GPM PER 100 PSI	MAX. PUMP PRESSURE INTERMITTENT DUTY	MAX. PUMP PRESSURE CONTINUOUS DUTY	SPEED MAX. RPM	A
D1	0.49	0.00028	0.065	0.015	2400	1500	5000	2.82
D2	0.82	0.00047	0.108	0.017	2400	1500	5000	2.91
D4	1.41	0.00081	0.187	0.020	2400	1500	4000	3.08
D6	2.39	0.00137	0.316	0.025	1750	1100	3000	3.36
D8	3.53	0.00202	0.468	0.030	1200	750	1800	3.68

**WARNING:** The specifications/application data shown in our catalogs and data sheets are intended only as a general guide for the product described (herein). Any specific application should not be undertaken without independent study, evaluation, and testing for suitability.

Phone: (815) 397-6628

Fax: (815) 397-2526

E-mail: [delta@delta-power.com](mailto:delta@delta-power.com)

D1-D8 Pump, Bi-Directional

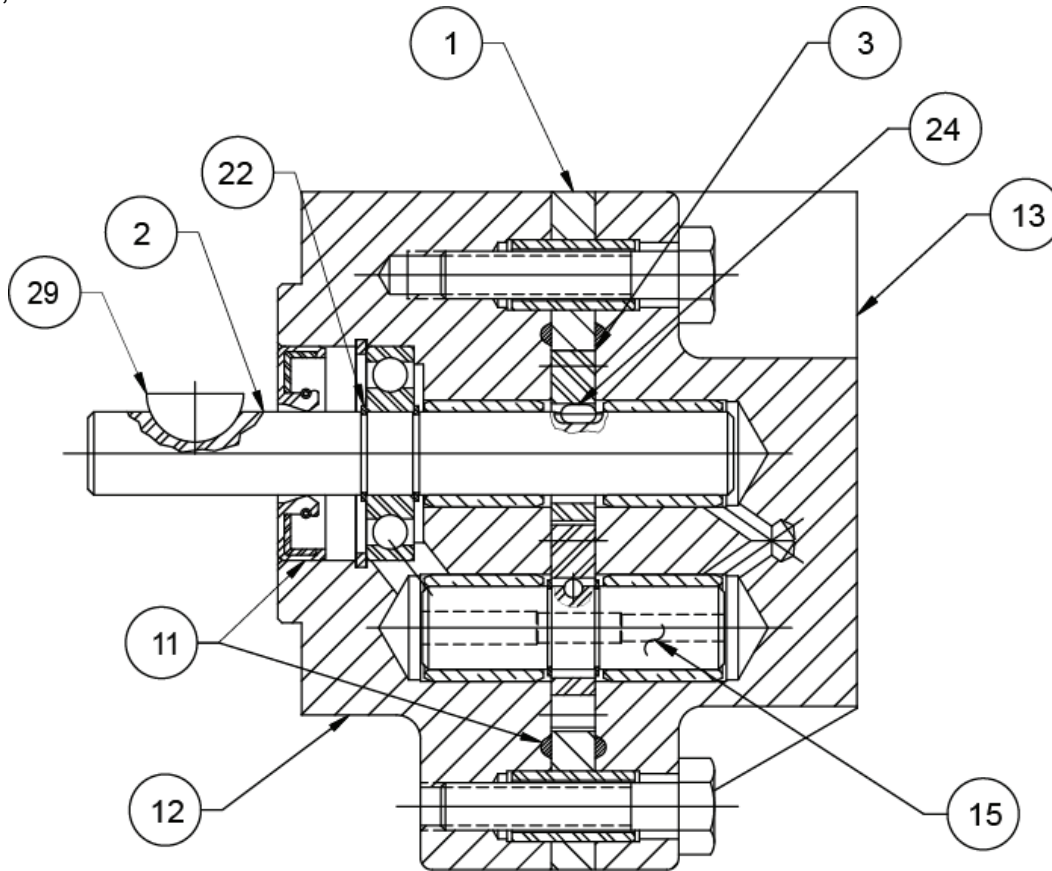

SECTION A-A

ITEM #	DESCRIPTION	QTY.
1	GEAR CASE	1
2	DRIVE SHAFT	1
3	GEAR	1
11	SEAL KIT	1
12	DRIVE PLATE ASS'Y	1
13	END PLATE ASS'Y	1
15	IDLER SHAFT ASS'Y	1
22	GEAR PIN	1
24	RETAINING RING	2
28	OUTBOARD BEARING	1
29	DRIVE KEY	1
31	SNAP RING	1

**WARNING:** The specifications/application data shown in our catalogs and data sheets are intended only as a general guide for the product described (herein). Any specific application should not be undertaken without independent study, evaluation, and testing for suitability.

**D21-D27 Pump, Bi-Directional**

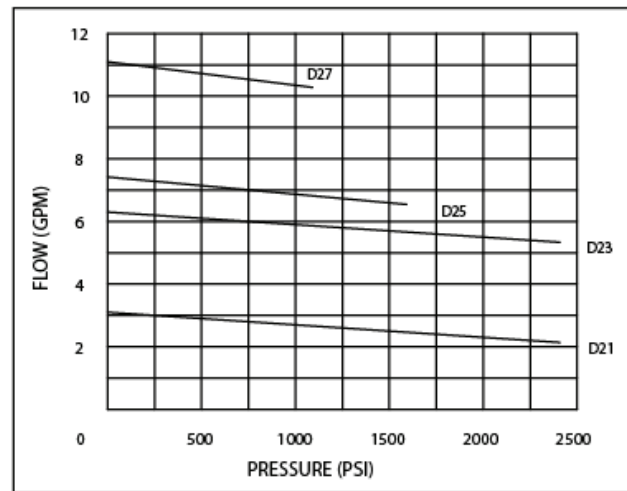
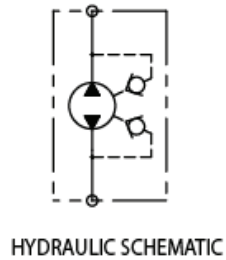
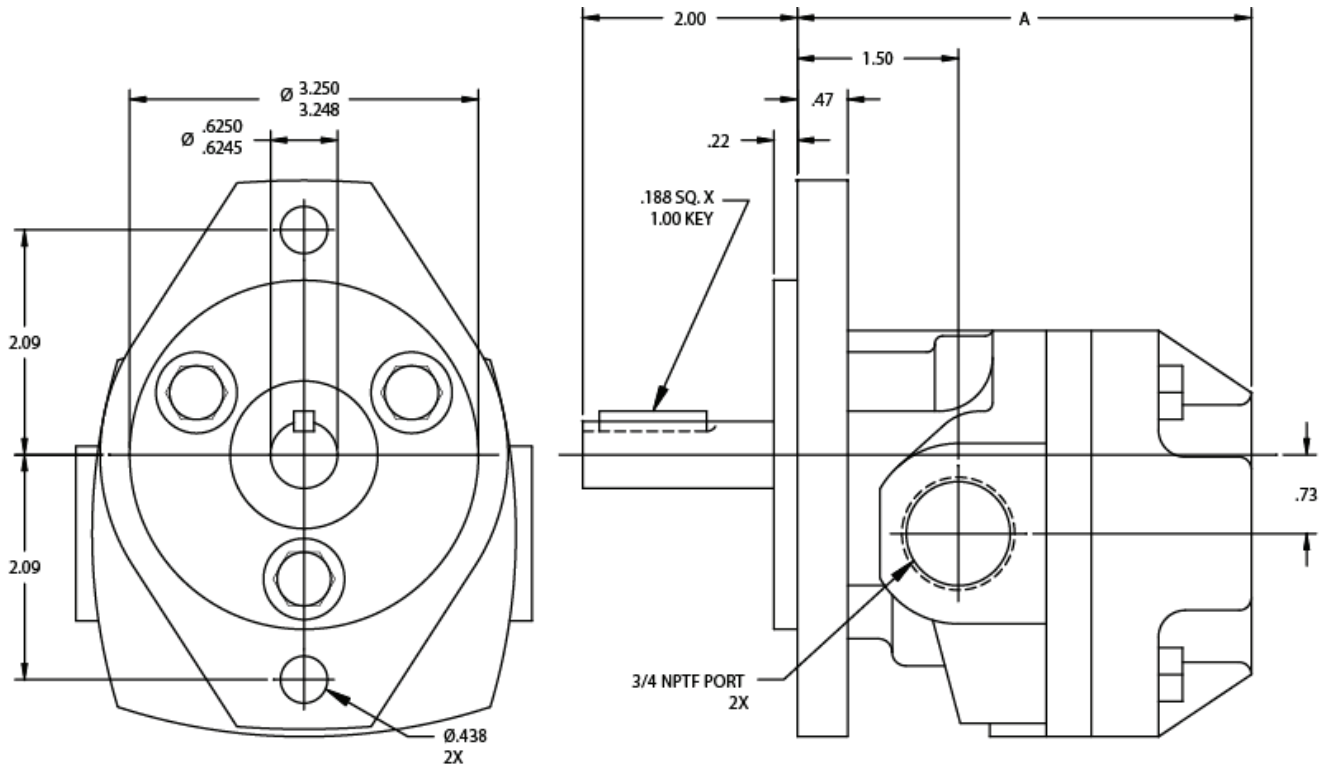

MODEL	GPM AT 1750 RPM	0 PSI DISP. GAL./REV.	DISP. CU. IN./REV.	SLIP GPM PER 100 PSI	MAX. PUMP PRESSURE INTERMITTENT DUTY	MAX. PUMP PRESSURE CONTINUOUS DUTY	SPEED MAX. RPM	A
D21	3.10	0.00178	0.411	0.040	2400	1500	5000	3.21
D23	5.30	0.00304	0.702	0.045	2400	1500	4000	3.56
D25	7.42	0.00425	0.981	0.055	1600	1000	3000	3.78
D27	11.10	0.00633	1.460	0.075	1100	700	1800	4.21

**WARNING:** The specifications/application data shown in our catalogs and data sheets are intended only as a general guide for the product described (herein). Any specific application should not be undertaken without independent study, evaluation, and testing for suitability.

Phone: (815) 397-6628

Fax: (815) 397-2526

E-mail: [delta@delta-power.com](mailto:delta@delta-power.com)

D21-D27 Pump, Bi-Directional

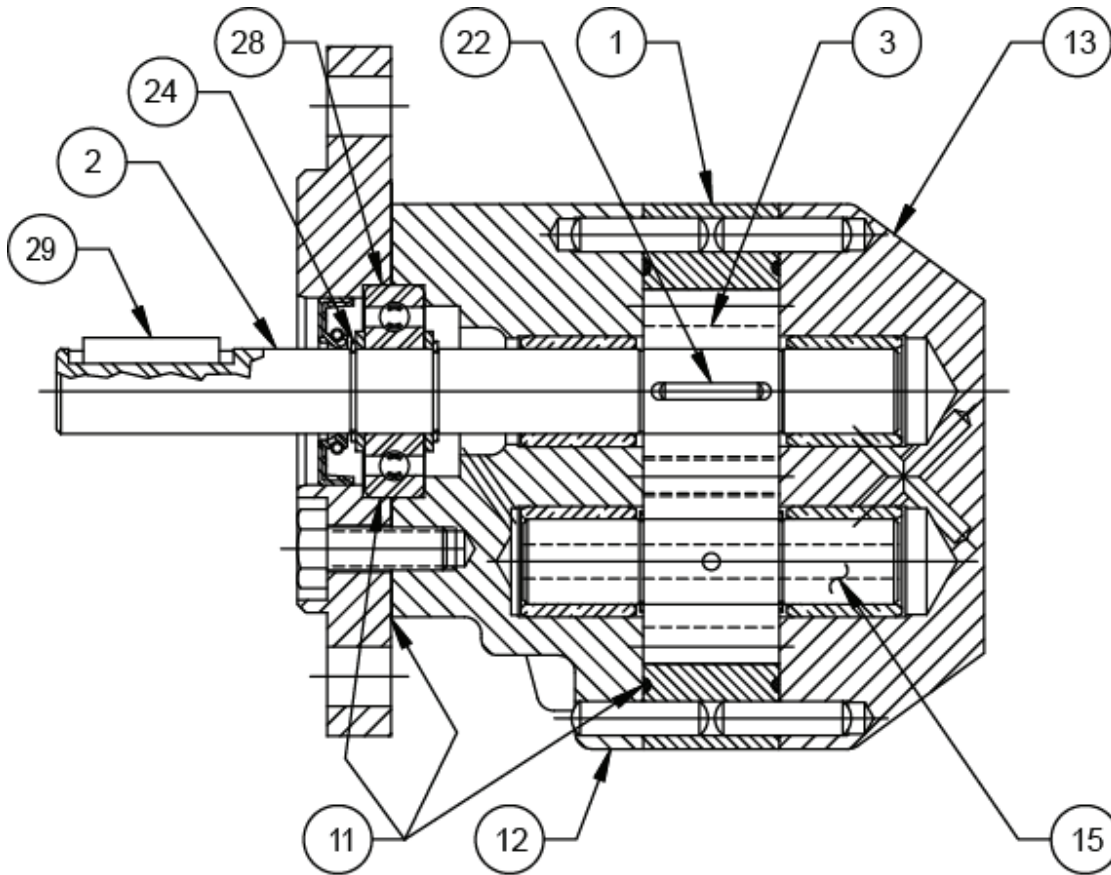

SECTION A-A

ITEM #	DESCRIPTION	QTY.
1	GEAR CASE	1
2	DRIVE SHAFT	1
3	GEAR	1
11	SEAL KIT	1
12	DRIVE PLATE ASS'Y	1
13	END PLATE ASS'Y	1
15	IDLER SHAFT ASS'Y	1
22	GEAR PIN	1
24	RETAINING RING	2
28	OUTBOARD BEARING	1
29	DRIVE KEY	1

**WARNING:** The specifications/application data shown in our catalogs and data sheets are intended only as a general guide for the product described (herein). Any specific application should not be undertaken without independent study, evaluation, and testing for suitability.



**D41-D49 Pump, Bi-Directional**

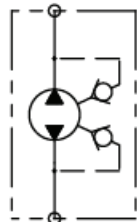
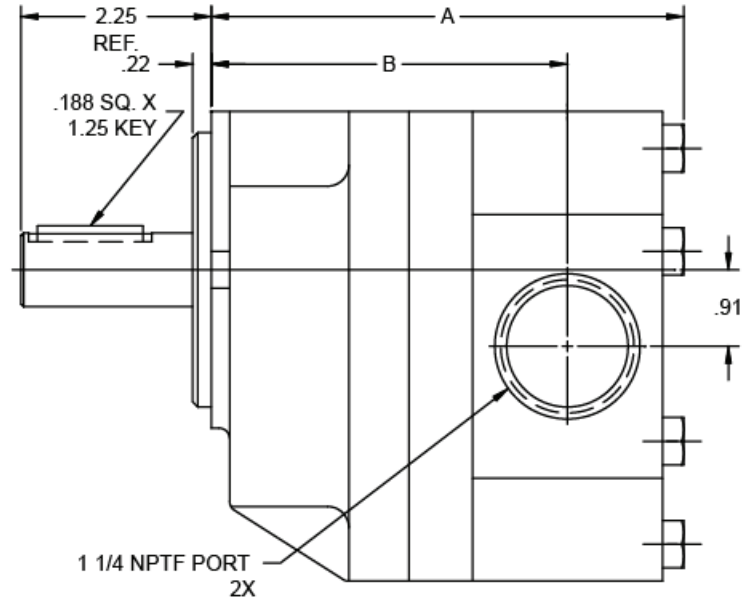
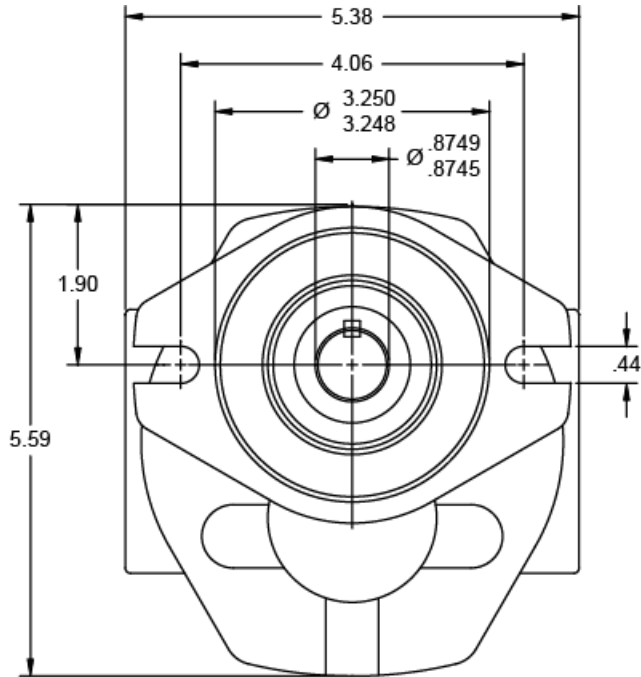

HYDRAULIC SCHEMATIC

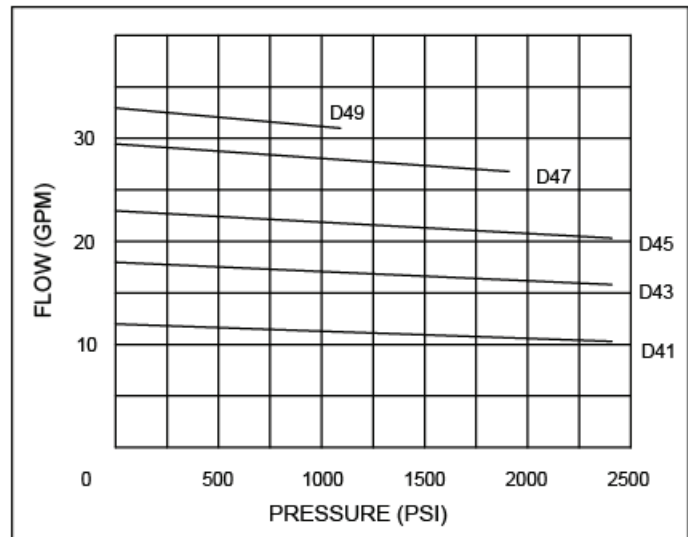

MODEL	GPM AT 1750 RPM	0 PSI DISP. GAL./REV.	DISP. CU. IN./REV.	SLIP GPM PER 100 PSI	MAX. PUMP PRESSURE INTERMITTENT DUTY	MAX. PUMP PRESSURE CONTINUOUS DUTY	SPEED MAX. RPM	A	B
D41	11.90	0.0068	1.570	0.070	2400	1500	4000	5.34	4.22
D43	17.80	0.0102	2.350	0.090	2400	1500	3000	5.72	4.59
D45	23.10	0.0132	3.040	0.110	2400	1500	2300	6.06	4.94
D47	29.50	0.0169	3.900	0.140	1900	1200	1800	6.47	5.34
D49	33.60	0.0192	4.430	0.180	1100	700	1800	6.72	5.59

**WARNING:** The specifications/application data shown in our catalogs and data sheets are intended only as a general guide for the product described (herein). Any specific application should not be undertaken without independent study, evaluation, and testing for suitability.

D41-D49 Pump, Bi-Directional

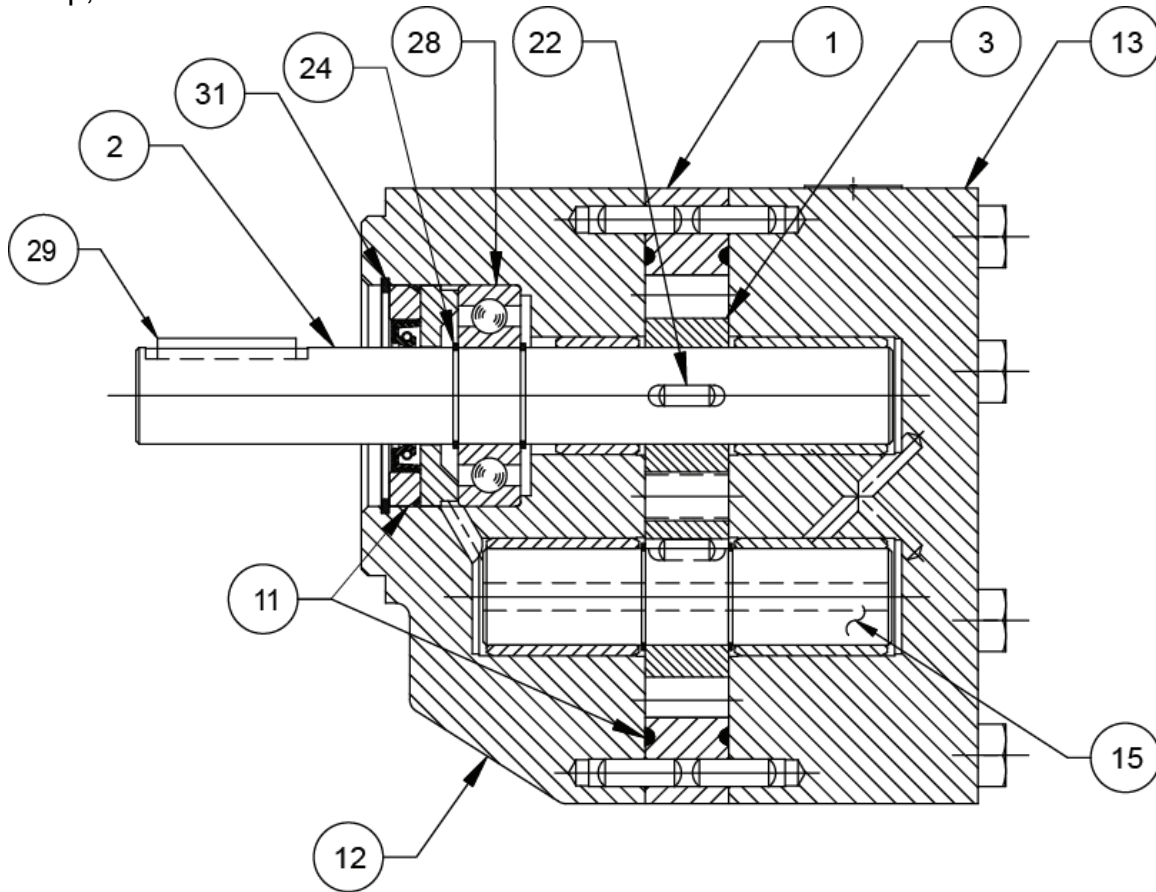

SECTION A-A

ITEM #	DESCRIPTION	QTY.
1	GEAR CASE	1
2	DRIVE SHAFT	1
3	GEAR	1
11	SEAL KIT	1
12	DRIVE PLATE ASS'Y	1
13	END PLATE ASS'Y	1
15	IDLER SHAFT ASS'Y	1
22	GEAR PIN	1
24	RETAINING RING	2
28	OUTBOARD BEARING	1
29	DRIVE KEY	1
31	SNAP RING	1

**WARNING:** The specifications/application data shown in our catalogs and data sheets are intended only as a general guide for the product described (herein). Any specific application should not be undertaken without independent study, evaluation, and testing for suitability.

**L Series 2 Stage HI-LO Pumps**

**L6 and L8 Series**



4F17 Mtg.  
Shown

**L24 and L26 Series**



4F17 Mtg.  
Shown

**While originally designed for log splitters, our enterprising distributors have found other unique applications.**

Two pump sections with different size gear sets in a single housing that provides, high speed positioning capabilities with efficient working pressures.

With multi circuit integration through internal valving to provide low pressure, high volume flow in the first stage and high pressure, low volume flow in the second stage.

- Direct couple to gas engines or AC electric motors at approx (3600 RPM).
- Require only a fraction of the engine horsepower that would be necessary with single stage pumps while providing much higher overall efficiency.

To adapt to a variety of applications, all pumps have an SAE 4F17 mounting flange plus an optional K4 mounting bracket for foot mounting.

MODEL	0 PSI DISP. IN <sup>3</sup> /REV	MAX. PSI	MAX. RPM	~GPM AT 3450 RPM	HP REQUIRED	INLET	OUTLET	PAGE
L6-2	.316 +.108	3000	3600	6.0\1.0	4	3/4 NPTF	1/2 NPTF	23
L8-4	.468 + .187	3000	3600	9.0\2.0	6	3/4 NPTF	1/2 NPTF	23
L24-2	.880 + .222	3000	3600	16\2.5	10	1" TUBE	3/4 NPTF	25
L26-2	1.000 + .416	3000	3600	20\5.0	12	1.25 " TUBE	3/4 NPTF	25

Note: Displacement given as larger gear set + smaller gear set.

~ GPM given as combined flow\sequenced flow.

Operation @1725 RPM will give ~ 50% of combined flow and ~ 40% of sequenced flow.

Unloading Valve Settings: Factory set at 500 PSI for L6 and L8 models; 600 PSI for L24 and L26 models.

Rotation: All models rotate clockwise facing pump shaft.

Mounting: 4F17 four bolt all models.

**WARNING:** The specifications/application data shown in our catalogs and data sheets are intended only as a general guide for the product described (herein). Any specific application should not be undertaken without independent study, evaluation, and testing for suitability.

**L6 and L8 Series 2 Stage HI-LO Pumps**

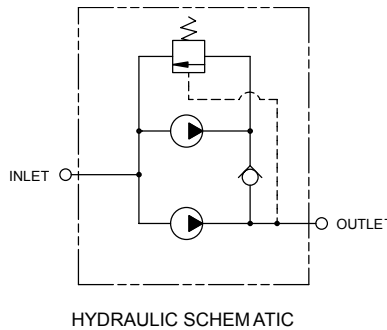
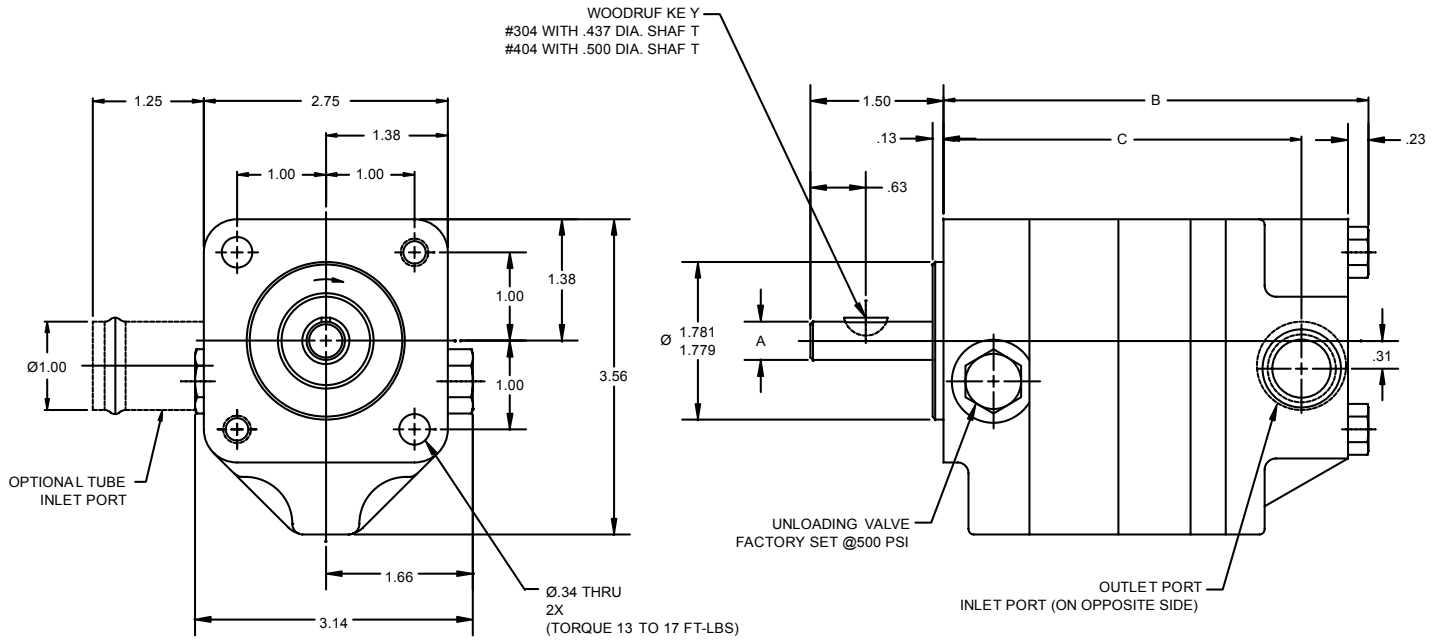

Unloading Valve is factory set at 500 PSI.  
 Rotation: All models rotate clockwise facing pump shaft or drive end (CWDE).  
 Mounting: 4F17 four bolt all models.

MODEL	0 PSI DISP. IN <sup>3</sup> /REV	MAX. PSI	MAX. RPM	~GPM AT 3450 RPM	HP REQUIRED	INLET	OUTLET	A	B	C
L6-2	.316 +.108	3000	3600	6.0\1.0	4	3/4 NPTF	1/2 NPTF	0.437	4.29	3.37
L8-4	.468 + .187	3000	3600	9.0\2.0	6	3/4 NPTF	1/2 NPTF	0.437	4.79	3.87

Note: Displacement given as larger gear set + smaller gear set.  
 ~ GPM given as combined flow\sequenced flow.  
 Operation @1725 RPM will give ~ 50% of combined flow and ~ 40% of sequenced flow.

**WARNING:** The specifications/application data shown in our catalogs and data sheets are intended only as a general guide for the product described (herein). Any specific application should not be undertaken without independent study, evaluation, and testing for suitability.

L6 and L8 Series 2 Stage HI-LO Pumps

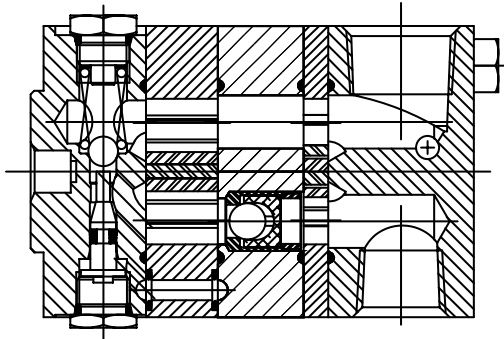

SECTION B-B

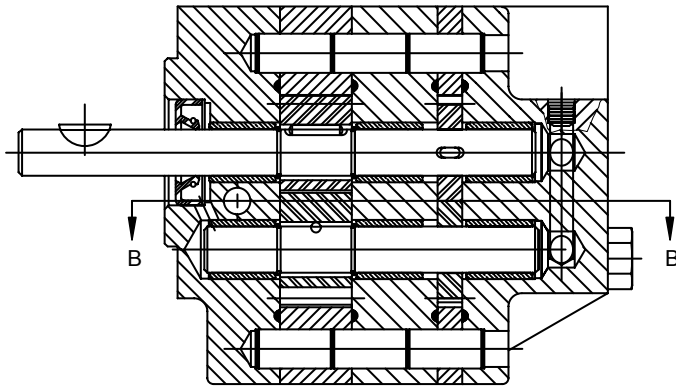

SECTION A-A

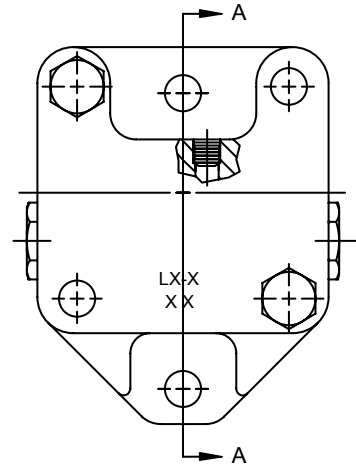

**WARNING:** The specifications/application data shown in our catalogs and data sheets are intended only as a general guide for the product described (herein). Any specific application should not be undertaken without independent study, evaluation, and testing for suitability.

**L24 and L26 Series 2 Stage HI-LO Pumps**

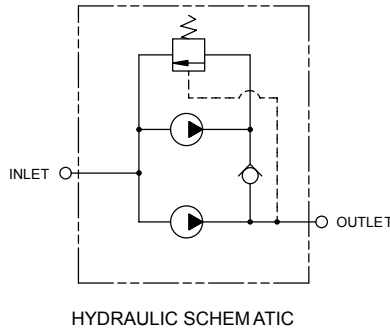
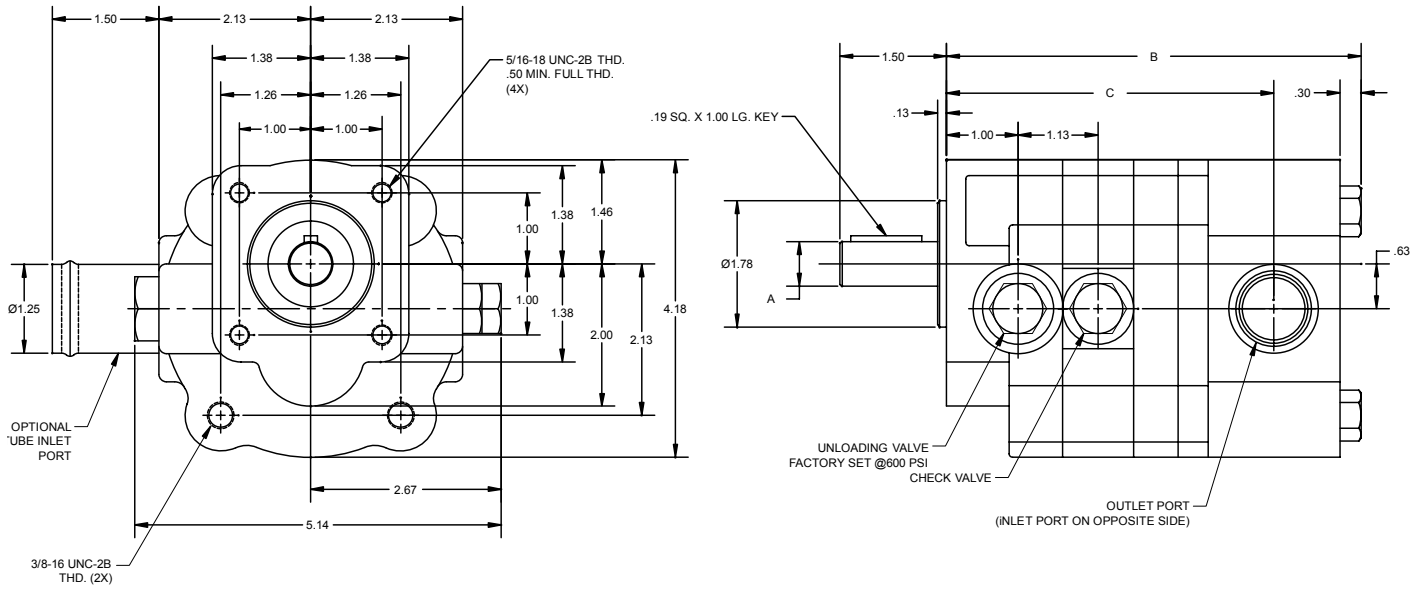

Unloading Valve is factory set at 600 PSI.  
 Rotation: All models rotate clockwise facing pump shaft or drive end (CWDE).  
 Mounting: 4F17 four bolt all models.

MODEL	0 PSI DISP. IN <sup>3</sup> /REV	MAX. PSI	MAX. RPM	~GPM AT 3450 RPM	HP REQUIRED	INLET	OUTLET	A	B	C
L24-2	.880 + .222	3000	3600	16\2.5	10	1 NPTF	3/4 NPTF	0.625	5.52	4.30
L26-2	1.000 + .416	3000	3600	20\5.0	12	1.25 " TUBE	3/4 NPTF	0.625	5.82	4.59

Note: Displacement given as larger gear set + smaller gear set.  
 ~ GPM given as combined flow\sequenced flow.  
 Operation @1725 RPM will give ~ 50% of combined flow and ~ 40% of sequenced flow.

**WARNING:** The specifications/application data shown in our catalogs and data sheets are intended only as a general guide for the product described (herein). Any specific application should not be undertaken without independent study, evaluation, and testing for suitability.

L24 and L26 Series 2 Stage HI-LO Pumps

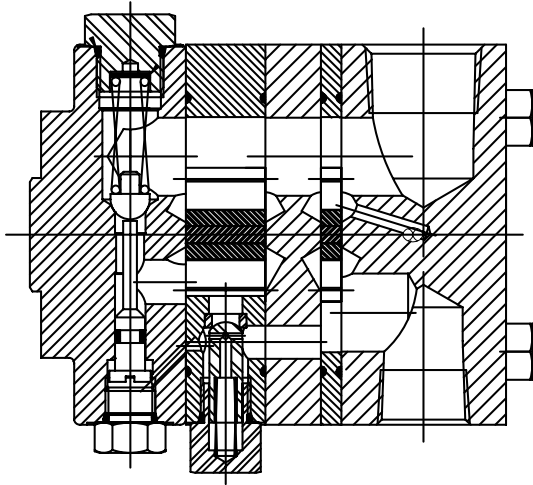

SECTION B-B

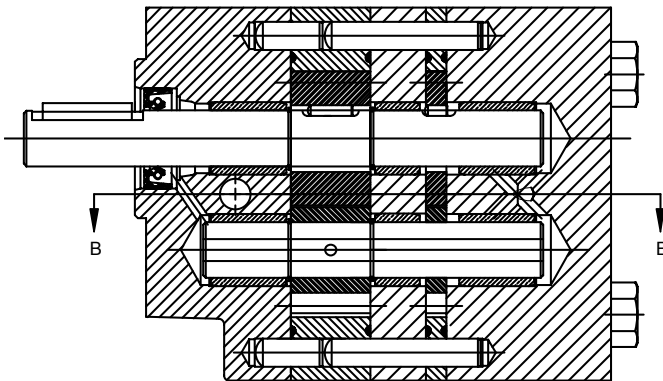

SECTION A-A

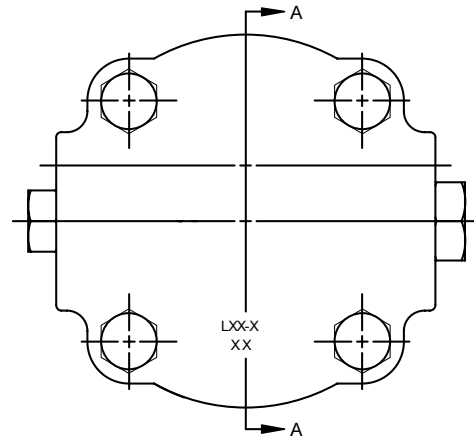

**WARNING:** The specifications/application data shown in our catalogs and data sheets are intended only as a general guide for the product described (herein). Any specific application should not be undertaken without independent study, evaluation, and testing for suitability.