



G-04

GREENCO

CABLE CYLINDERS

CABLE-TROL®
TRAC-TROL®
POWR-TUBE®
AIR-OIL TANK

Serving
Industry
For Over
25 Years.

ISO 9001:2000
CERTIFICATION
No. 5047 1494

GREENCO

LEADERS IN RODLESS CYLINDERS™

QUALITY CONSTRUCTION THROUGHOUT

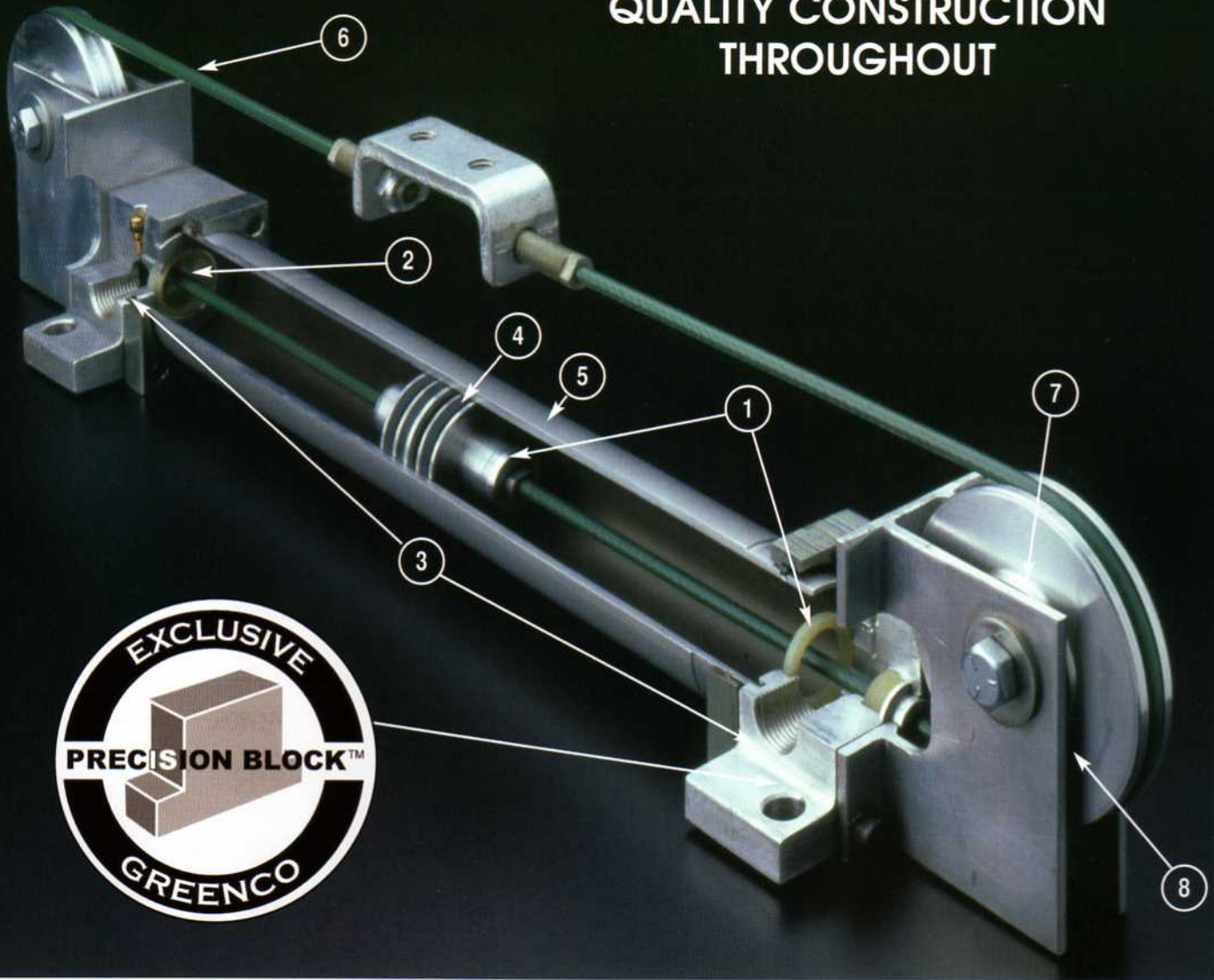

- 1. QUALITY PNEUMATIC CUSHIONING** – The fully adjustable cushioning brings the piston to a gentle stop at the end of each stroke. Rate of deceleration is controlled by a self-locking needle adjustment valve. Models 07 and 10 have fixed cushioning.
- 2. FAST BREAKAWAY** with quality pneumatic cushioning. A flexible polyurethane cushion seal allows faster break-away on models 15 - 50.
- 3. EXCLUSIVE PRECISION BLOCK** provides the strongest possible bridge between sheave bracket and tube. N.F.P.A. specifications for foot, flange or tapped hole mounting.
- 4. HIGH STRENGTH ALUMINUM PISTON** – Low friction aluminum piston has greater impact strength than ordinary cast iron type. Provides excellent wearing and corrosion resistant qualities. Each piston is precision machined, polished and securely fastened to the cable.
- 5. PRECISION CYLINDER TUBE** – Standard in hard-coated aluminum. Also available in steel with painted exterior or plated steel providing rugged strength, low friction and corrosion resistance.

- 6. NYLON COATED STEEL CABLES** – An aircraft-type steel cable replaces the piston rod. A nylon coating acts as a smooth sealing surface. Cylinder always "pulls" the load through tension on the cable.
- 7. PRECISION SHEAVES** – These guide the cable through the seal in accurate alignment. The precision sheaves also protect the cable coating for longer seal-cable life. Exclusive symmetrical bolt-on construction allows the sheave to be located in any of four positions (90° apart) with respect to the mounting.
- 8. FACTORY-LUBRICATED NEEDLE BEARINGS** – Precision, pre-lubricated needle bearings can be repacked in the field.
- 9. EQUAL FORCE IN BOTH DIRECTIONS** – Since the cable area is relatively small the "push" and "pull" forces and volume displacement are approximately equal for either single or double ended styles.
- 10. SAVE SPACE – REDUCE UNIT WEIGHT** – The length of a cable cylinder is little more than half that of a conventional piston rod cylinder. Length is always constant, providing the designer with new freedom of arrangement. There is no extended or retracted length. The extra weight of the piston rod is also eliminated by using cable cylinders.

**NOTE: SPECIFICATIONS & DIMENSIONS
MAY BE CHANGED WITHOUT NOTICE.****DESCRIPTION, APPLICATION & ORDERING INFORMATION**

Applications	2, 3
How To Order	4
Engineering Specifications	5, 6, 7
Automatic Tensioner & Optional Accessories	8, 9
Reed Switches & Repair Kits	10
Air/Oil Tank	11

FEATURES & DIMENSIONS CABLE-TROL®

Models 07, 10	12, 13
Models 15-50, 20P & 25P Features	14
Models 15-40 Dimensions	15
Models CS 15-40 & Tube Support Dimensions	16
Models 50 Dimensions	17

FEATURES & DIMENSIONS TRAC-TROL®

Trac-Trol® Features	18
Trac-Trol® & Model TS10 Supported Dimensions	19
Trac-Trol® Supported Dimensions	20
Trac-Trol® Shock Absorber Package	21
Powr-Tube®	22, 23
Typical Control Circuits	24
Rodless Cylinder Comparison	Inside Back Cover
Other Greenco Products	Back Cover

PRECAUTIONS

Greenco Manufacturing Corporation ("Greenco") products are manufactured exclusively for use in industrial applications by trained personnel who possess the experience necessary to provide adequate safeguards to prevent injury or damage. The products must not be subjected to abuse, misuse, or overuse. The products must be periodically inspected and maintained properly, including but not limited to cable inspection and replacement upon first signs of fatigue, fraying, or damage. The products must not be used in applications that could subject a user to risk of death or injury, nor in applications where pressure, temperature, or load exceed maximum operating conditions. Refer to product specifications.

In lubrication applications, some oil mist may escape from the point of use into the surrounding atmosphere. Users are referred to OSHA safety and health standards for limiting oil mist contamination and utilization of protecting equipment.

In reed switch applications, be sure to connect the reed switch to the power source through a load. Direct connection of the switch may cause damage to the internal elements of the switch. To prevent electric shock, always shut off power supply before handling electric wire leads.

LIMITED WARRANTY

Greenco products are warranted for a period of one (1) year from the date of shipment from the factory to be free from defects in material and workmanship under correct use, normal operating conditions, and proper applications. The company will repair or replace, at its option, any product found to be defective after inspection. Greenco shall not be liable or responsible for injuries or damage to persons or property arising out of the use or operation of Greenco products. This warranty does not apply to goods damaged, abused, or misused after shipment from Greenco.

Customer must obtain a Return Goods Authorization from Greenco prior to shipping product for warranty evaluation, and the product must be returned within ten (10) working days of the return authorization date. A written explanation of the complaint must accompany the product, and it must be marked with the return authorization number. Product must be returned freight prepaid. Greenco shall not be liable for material returned without prior authorization. Following a repair of returned products, the product will be covered for the remainder, if any, of the original warranty period on the date it was returned.

THIS WARRANTY IS IN LIEU OF ALL OTHER WARRANTIES, EXPRESS OR IMPLIED, INCLUDING ANY IMPLIED WARRANTY OF MERCHANTABILITY OR FITNESS FOR A PARTICULAR PURPOSE, NOTWITHSTANDING ANY DISCLOSURE TO GREENCO OF THE USE TO WHICH THE PRODUCT IS TO BE PUT. THE BUYER'S SOLE AND EXCLUSIVE REMEDY ON ANY CLAIM OF ANY KIND FOR ANY LOSS OR DAMAGE ARISING OUT OF THE MANUFACTURE, SALE, DELIVERY OR USE OF GREENCO'S PRODUCTS SHALL BE FOR THE REPAIR OR REPLACEMENT OF ANY DEFECTIVE PRODUCTS AS PROVIDED HEREIN.

In no event shall Greenco be liable for any special, incidental or consequential damages. There are no warranties, express or implied, made by Greenco other than the warranty against defects in material and workmanship set forth above, and Greenco neither assumes nor authorizes any other person or firm to assume for it any other obligations or liability.

If any portion of this Limited Warranty is deemed unenforceable under any applicable law, the remainder of this Limited Warranty shall nevertheless be in full force and effect.

GOODS NOT MANUFACTURED by Greenco are furnished subject only to the manufacturer's warranties, if any, and without warranties, express or implied, by Greenco.

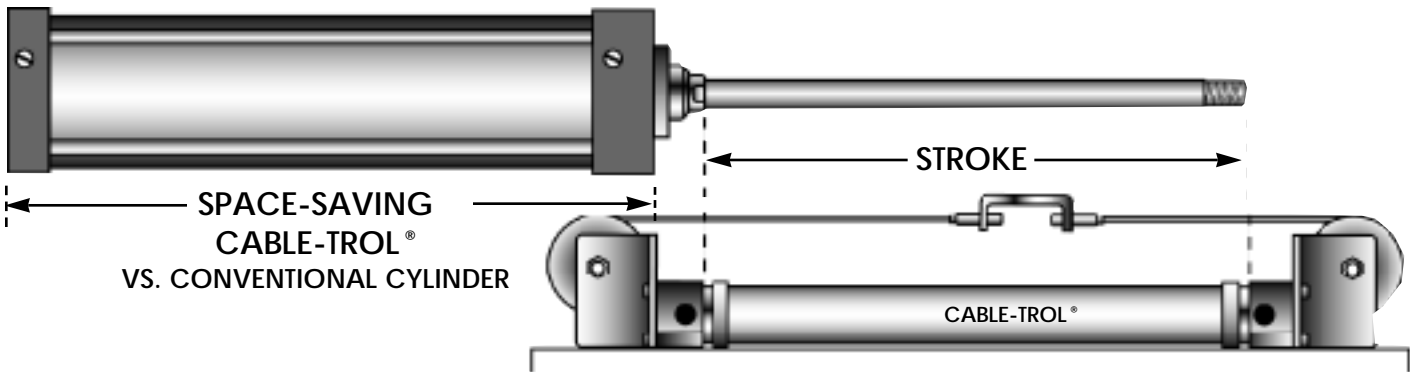

CABLE-TROL® cylinders provide the same stroke as conventional cylinders with about **50% SPACE SAVINGS**. As the piston is pushed in one direction, the load is pulled in

the opposite direction, within the length of the cylinder. Effective piston area is greater than in conventional rod cylinders, and there is equal force in both directions.

Requirement	Conventional Piston Rod Cylinder	CABLE-TROL®
LONG STROKE	HIGH COST SPECIAL	EVERYDAY STANDARD
LIMITED SPACE	CAN'T REDUCE - MUST ALLOW FOR TUBE PLUS STROKE	SAVES SPACE - STROKE PARALLELS TUBE
PUSH-PULL LOAD AROUND CORNERS	CAN'T DO	JUST UTILIZE STANDARD SHEAVE ACCESSORIES WITH CABLE-TROL®
ROTARY MOTIONS	CAN'T DO	NO PROBLEM - USE EXTRA CABLE & WRAP AROUND DRUM
CONCEALED LOCATION	REAL PROBLEM	IDEAL - SIMPLY EXTEND CABLE THROUGH COVER PLATE AND CONNECT TO LOAD

TYPICAL APPLICATIONS

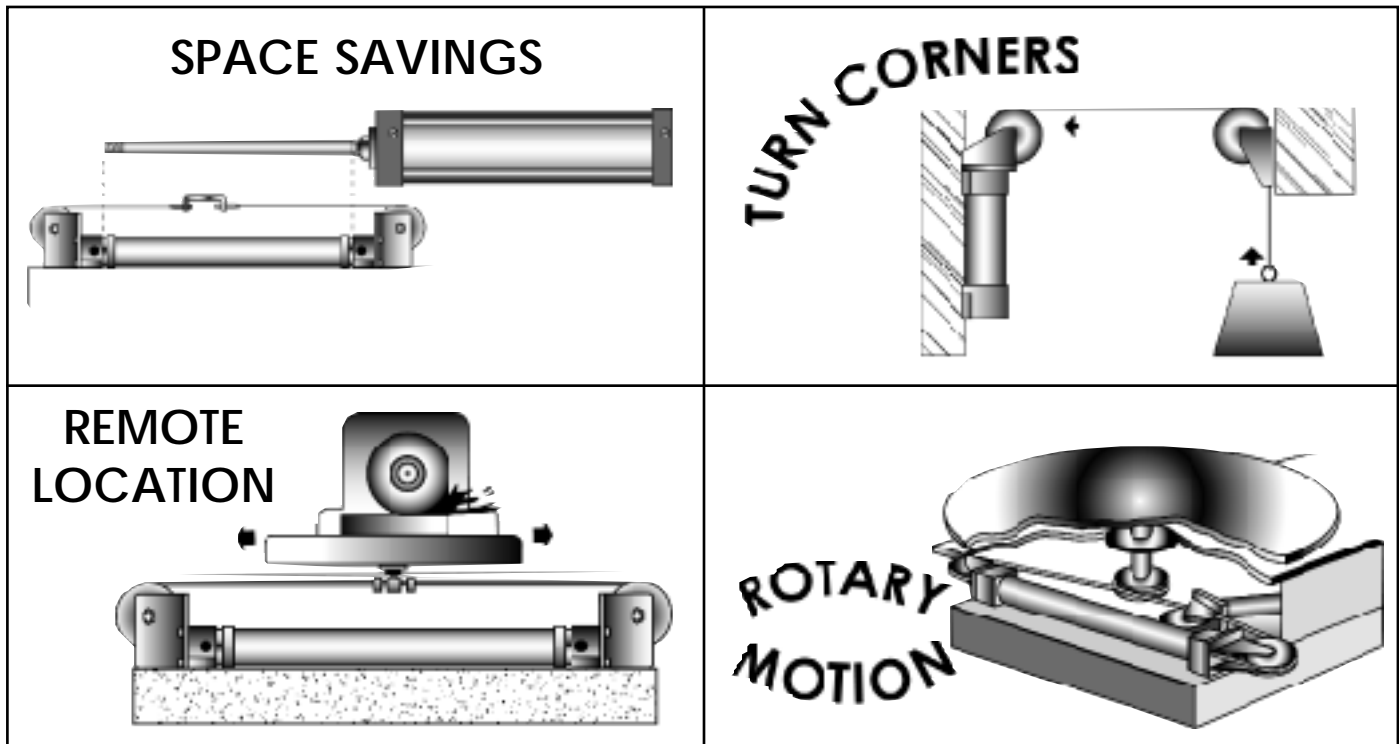

REMOTE LOCATION

CABLE-TROL® sheave assemblies can be ordered separately, as can additional cable. This allows the cylinder to be mounted remotely from where the load is to be moved. This is especially useful in harsh environments.

ROTARY MOTION

The cable can be attached to virtually anything. CABLE-TROLS® have been used to rotate valves, loading chutes, even amusement park displays.

SLIDING DOORS OR WINDOWS

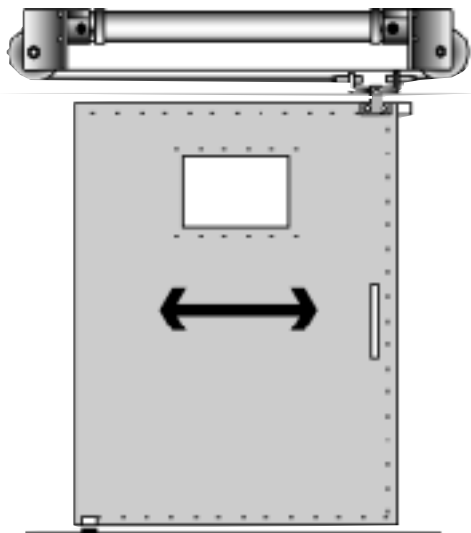

SWITCHING CONVEYOR LINES

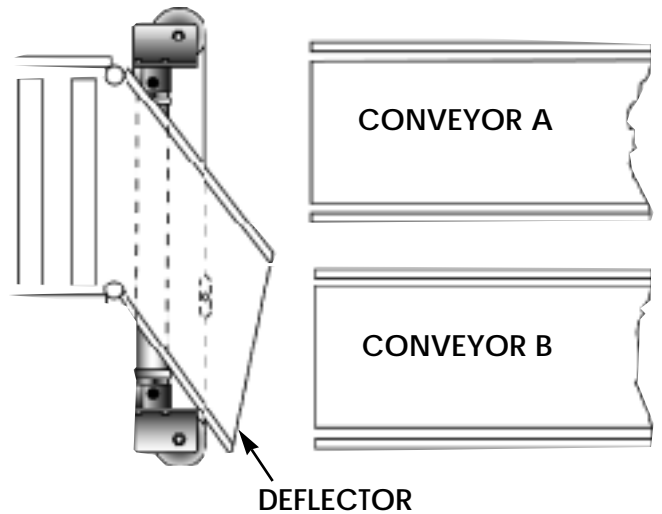

FEED PUNCH PRESS WITH STOCK AND TRANSFER FINISHED PIECE

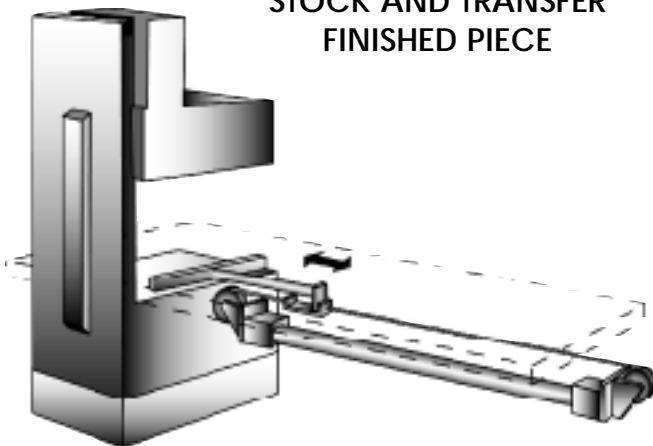

AUTOMATE SPRAY PAINT RIG, ROTATE TABLE AND RECIPROCATATE NOZZLE

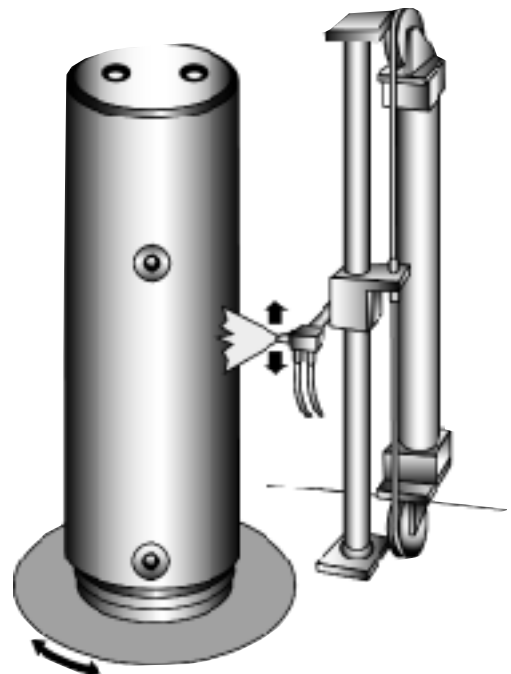

Unless otherwise specified all units are

1) base mounted (precision block except models 07, 10, 40 & 50), 2) side ports, and 3) Sheave/Trolleys at position 1.

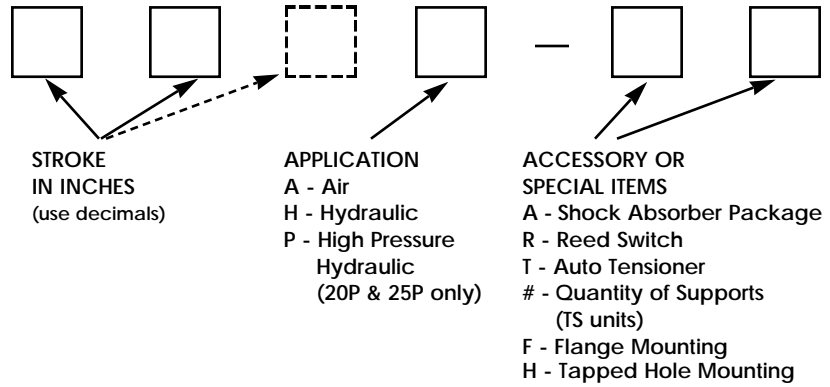
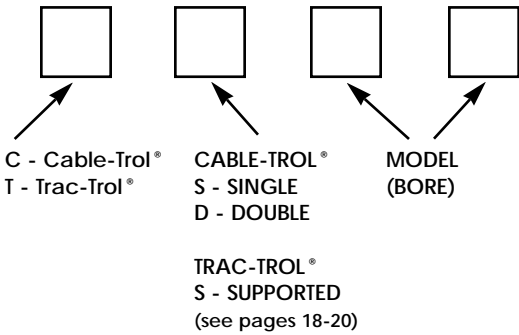

EXAMPLES:

CD20156A-T - Cable-Trol®, double end, 2" bore x 156" stroke, air service, automatic tensioner.

T1524H - Trac-Trol®, 1 ½" bore, 24" stroke, hydraulic service.

TS2548.75A-2 - Supported Trac-Trol®, 2 ½" bore, 48.75" stroke, air service, 2 supports.

CD40132H-TR - Cable-Trol®, double ended, 4" bore, 132" stroke, hydraulic service, automatic tensioner, reed switch package.

TS15108A-AR-4 - Supported Trac-Trol®, 1 ½" bore, 108" stroke, air service, shock absorber package, reed switch package, 4 supports.

PORT, CUSHION & SHEAVE POSITIONS FOR MODELS 15 THROUGH 50.

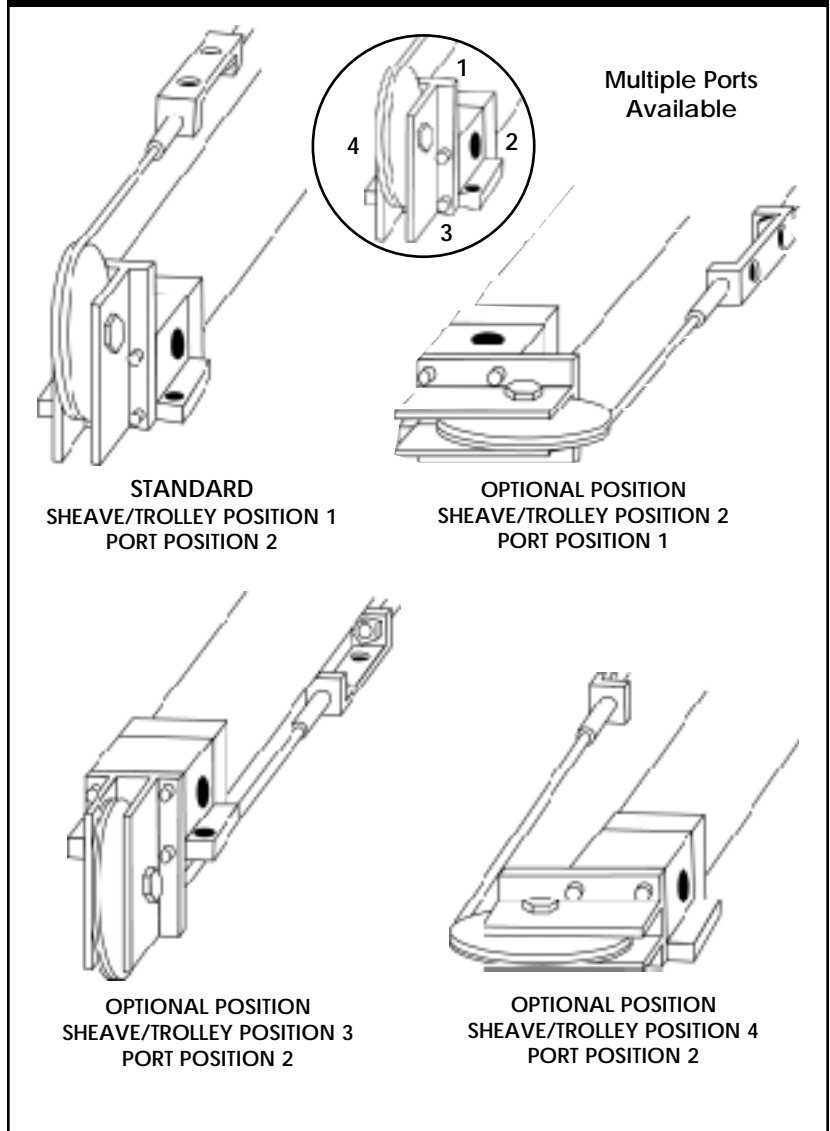

PORT POSITIONS FOR MODELS 07 & 10

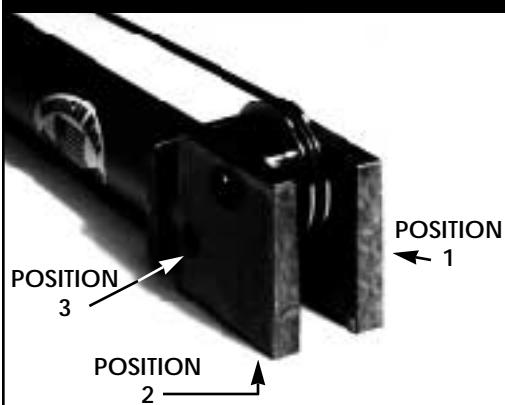

Side ports are standard on models 07 & 10.

MODEL SELECTION INFORMATION

The correct bore size of the cable cylinder can be determined in much the same manner in which a rod cylinder would be chosen. The fact that the effective area is

equal on both sides of the piston makes sizing a cable cylinder even easier. Table 1 gives the forces developed by each model at standard shop pressures.

TABLE 1

CYLINDER DATA					CABLE & CUSHION DATA						
(C) CABLE-TROL (T) TRAC-TROL MODEL	BORE (in.)	EFFECTIVE AREA (sq. in.)	FORCE (T & C) CAPACITY		WIRE DIA.	CABLE SPECIFICATIONS			CABLE FITTING (in)	INTERNAL CUSHION LENGTH (in.)	MAX INERTIA W/INTERNAL CUSHIONS (lbs.)
			80 PSI	150 PSI		NYLON O.D.	STRAND CONFIG.	TENSILE STGH. (lbs.)			
(C) 07	.75	.4348	34.7	65.2	3/64" std.* 1/16" opt.	3/32" 3/32"	7 x 7 7 x 7	270 480	1/4-28 x .82	.375 .375	11 19
(T & C) 10	1.00	.7785	62.3	116.8	3/64" std.* 1/16" opt.	3/32" 3/32"	7 x 7 7 x 7	270 480	1/4-28 x .82	.375 .375	27 47
(T & C) 15	1.50	1.7395	139.2	260.9	1/8"	3/16"	7 x 19	2000	3/8-24 x 1 11/16	.75	205
(T & C) 20	2.00	3.0925	247.4	463.9	5/32"	1/4"	7 x 19	2800	5/8-18 x 1 5/8	.75	357
(T & C) 25	2.50	4.8597	388.8	728.9	5/32"	1/4"	7 x 19	2800	5/8-18 x 1 5/8	.75	463
(T & C) 32	3.25	8.2191	657.5	1232.9	3/16"	5/16"	7 x 19	4200	3/4-16 x 2 1/4	.88	862
(T & C) 40	4.00	12.4560	996.5	1868.4	1/4"	3/8"	7 x 19	7000	3/4-16 x 2 1/2	.88	1410
(T & C) 50	5.00	19.5246	1562.	2928.7	1/4"	3/8"	7 x 19	7000	3/4-16 x 2 1/2	.88	1410
High Pressure Hydraulic			300 PSI	500 PSI **							
(T & C) 20P**	2.00	3.0925	927.7	1546.3	5/32"	1/4"	7 x 19	2800	5/8-18 x 2	.75	357**
(T & C) 25P**	2.50	4.7983	1439.5	2399.2	1/4"	3/8"	7 x 19	7000	3/4-16 x 2 1/2	.75	1158**

(1) To figure forces at other psi, multiply psi x effective area.

Example: model 15 at 50 psi equals 1.74 x 50.

* 3/64 cable is standard, 1/16 is optional.

** Model 20P & 25P - 300 PSI maximum for shock or pressure spike applications, 500 PSI non-shock.

Standard breakaway is 6 to 10 psi - low breakaway available upon request.

MODELS 07-50 - 150 psi max. Pneumatic or Hydraulic.

MODELS 20P-25P - 500 psi max. Hydraulic.

(T) Note - Force capacity does not indicate load capacity. See pages 18 & 20.

NOMENCLATURE

F = Inertia force in cable (lbs) must be less than 60% of cable tensile strength.

W = Maximum weight of load (lbs).

V = Maximum velocity of load (in/sec).

s = Stopping distance or cushion length (Table 1)

g = 386.4 in/sec²

f = Coefficient of friction between all sliding parts

- .10 ball bearing
- .15 needle bearing
- .30 journal bearings - nylon or bronze

q = angle of inclination of 0° - 90°
(horizontal q = 0°)

CUSHIONING FOR ALL MODELS

All Greenco cable cylinders are equipped with internal cushions to help decelerate the load without damaging the cylinder or cable.

Excessive inertia forces neutralize the internal cushions causing the cable to stretch and "whip". Eventually, the cable may break.

The following equations and information in Table 1 will determine if the internal cushions are adequate. If the calculations show that the cushions are inadequate, a cylinder with larger diameter cable should be selected or external shock absorbers should be used. See pg. 21.

The equations below determine the inertia force developed when the maximum weight, stopping distance and maximum velocity are known and when the load is moving.

Horizontally: $F = (\frac{V^2}{2sg} - f) W$

Upward Vertically: $F = (\frac{V^2}{2sg} - 1) W$

Downward Vertically: $F = (\frac{V^2}{2sg} + 1) W$

Upward on an Incline: $F = (\frac{V^2}{2sg} - \sin q - f \cos q) W$

Downward on an Incline: $F = (\frac{V^2}{2sg} + \sin q - f \cos q) W$

The value of "F" obtained from the equation can be compared to the "maximum inertia with internal cushions" found in Table 1 to select the best cylinder for application.

If external cushion devices with longer stopping distance are used, do not exceed 60% of cable tension strength for the value of "F".

By rearranging the first equation, the critical velocity for horizontal loads can be calculated for a known weight and cylinder bore.

$V = \sqrt{(F/W + f) 2sg}$

Use values for "F" and "s" from Table 1 when using internal cushions. Do not exceed this critical velocity unless external cushion devices are used.

CABLE STRETCH, PROOFLOADING AND TENSIONING FOR ALL MODELS

It is very important that cable cylinder cables are properly adjusted to obtain maximum cable and seal life.

Loose cables tend to “whip” at the beginning and end of the stroke, shortening cables and seal life. Excessive cable tension deteriorates the cable and its covering.

Properly tensioned cables prevent all this but periodic inspection is necessary to maintain maximum operating life.

All cables exhibit two types of stretch, constructional and elastic. When cable is stranded, the individual wires and strands are laid in their proper position but are slightly loose. When the cable is subjected to an initial load, the wires align themselves into a tighter position. This readjustment under tension is the constructional stretch.

Once the constructional stretch is removed by proofloading, any further stretch is elastic stretch which relates to the actual material characteristics.

Before operating the cylinder the constructional stretch must be eliminated by proofloading:

1. Tighten the trolley locknuts to the torque indicated on Table 2.
2. Maintain the proofload tension for 30 seconds.
3. Loosen nuts and repeat.

If a torque wrench is not available, the cable tension can be estimated using a common fish scale. Apply the fish scale at the midpoint of the span between two sheaves or between a sheave and the load. The fish scale should read the value indicated on Table 2 when the cable is pulled 1% of the span.

TABLE 2 - PROOFLOADING

MODELS	PROOFLOAD (LBS.)	TIGHTENING TORQUE (IN./LB.)	FISHSCALE (LB.)
07, 10	162	15	1 2/3
15	1200	75	12
20, 20P, 25	1680	150	17
32	2520	260	25 1/2
25P, 40, 50	4200	415	42

After the constructional stretch has been eliminated by proofloading, the cables can be tightened to the operating tension. With the load physically blocked in midstroke, apply operating pressure to one end of the cylinder. Tighten the slack cable to the value indicated on Table 3 (the torques listed are for maximum rated pressure). Repeat the procedure with operating pressure applied to the opposite end. The fish scale method could be use here also, but would take more time to obtain the correct tension.

TABLE 3 - CABLE OPERATING TENSION (at maximum rated pressure)

MODELS	TORQUE (IN./LB.)	FISHSCALE (LB.)
07	12	2/3
10	14	1 1/3
15	32	2 2/3
20	60	4 2/3
25	80	7 1/3
32	140	12 1/2
40	200	19
50	300	30
20P	140	15 1/2
25P	245	24

OPERATION & INSTALLATION FOR ALL MODELS

OPERATION: Operate the cable cylinder just same as you would any other cylinder. Be sure to operate it at pressures within the catalog ratings. For air operation, use a **filter-regulator-lubricator** in the supply line to protect your valves and the cylinder. Use a flow control valves to control speed in each direction. Adjust the cushion needle valves to get smooth stopping at each end of the stroke without bounce or impact. Flow control valves are always desirable for speed control and improved cushion action. For heavier loads and higher speeds, shock absorbers should be used.

To insure acceptable life, the application should be within the limits of the recommendations below.

- For most applications, maximum velocity of 5 feet per second. See page 21.
- Maximum operating pressure 150 psi air and oil (500 psi on hydraulic modes 20P and 25P) on Cable-Trol®.
- Temperature range 32 - 150° F.

INSTALLATION: The cylinder should be mounted firmly to the machine, utilizing the two mounting holes in each head. Pipe air or oil lines making sure that no fitting is scraping the cable or sheave. The cylinder should then be cycled a minimum of 20 times, after which the cable should be retensioned. This procedure should be followed again after the first eight hours of use.

MOUNTING TROLLEY MODELS: Mount the cable cylinder parallel to the load path so that the trolley can move the load through the full designed stroke of the cylinder. Bolt or pin the trolley to the load so that the load does not pull the trolley off its path of travel. Avoid twisting the trolley in any way that could increase or vary cable tension during the full stroke.

MOUNTING NON-TROLLEY MODELS: Mount the cable cylinder so that the cable leaves the sheave on the center of the groove. Connect the cable to the load using GREENCO re-usable cable terminals in such a way that the cable tension will not vary during the stroke.

TABLE 4 - WEIGHT & TUBING SPECIFICATIONS

	MODEL	BORE	WALL THICKNESS	APPROXIMATE BASE WEIGHT			WEIGHT PER FOOT	
				SINGLE ENDED	DOUBLE ENDED	WITH TENSIONER	ALUMINUM	STEEL
CABLE-TROL®	07	3/4 inch	1/8 inch	.75 lbs.	1.25 lbs.	2.25 lbs.	.40 lbs.	N/A
	10	1 inch	1/8 inch	.75 lbs.	1.25 lbs.	2.25 lbs.	.52 lbs.	1.45 lbs.
	15	1 1/2 inches	1/8 inch	2.50 lbs.	5.00 lbs.	8.50 lbs.	.75 lbs.	2.10 lbs.
	20	2 inches	1/8 inch	5.25 lbs.	10.50 lbs.	16.50 lbs.	.98 lbs.	2.73 lbs.
	25	2 1/2 inches	1/8 inch	7.75 lbs.	15.50 lbs.	21.50 lbs.	1.21 lbs.	3.50 lbs.
	32	3 1/4 inches	1/8 inch	16.00 lbs.	32.00 lbs.	37.00 lbs.	1.56 lbs.	4.47 lbs.
	40	4 inches	1/8 inch	26.50 lbs.	52.00 lbs.	60.00 lbs.	1.88 lbs.	5.46 lbs.
	50	5 inches	1/8 inch	32.75 lbs.	65.00 lbs.	74.00 lbs.	2.37 lbs.	N/A
	20P	2 inches	1/8 inch	5.75 lbs.	11.50 lbs.	N/A	.98 lbs.	2.73 lbs.
TRAC-TROL®	25P	2 1/2 inches	1/8 inch	8.25 lbs.	16.50 lbs.	24.50 lbs.	1.21 lbs.	3.50 lbs.
	10	1 inch	1/8 inch	N/A	3.00 lbs.	4.00 lbs.	1.50 lbs.	3.00 lbs.
	15	1 1/2 inches	1/8 inch	N/A	7.75 lbs.	10.25 lbs.	1.80 lbs.	3.60 lbs.
	20	2 inches	1/8 inch	N/A	11.75 lbs.	18.25 lbs.	2.00 lbs.	4.00 lbs.
	20P	2 inches	1/8 inch	N/A	12.50 lbs.	N/A	2.61 lbs.	5.12 lbs.
	25	2 1/2 inches	1/8 inch	N/A	22.00 lbs.	28.00 lbs.	2.70 lbs.	5.40 lbs.
	25P	2 1/2 inches	1/8 inch	N/A	23.50 lbs.	29.50 lbs.	2.90 lbs.	5.80 lbs.
	32	3 1/4 inches	1/8 inch	N/A	43.00 lbs.	49.00 lbs.	4.10 lbs.	8.20 lbs.
	40	4 inches	1/8 inch	N/A	57.00 lbs.	66.00 lbs.	5.20 lbs.	10.40 lbs.
50	5 inches	1/8 inch	N/A	77.00 lbs.	87.00 lbs.	5.90 lbs.	11.18 lbs.	

The data presented in the above chart are average values and may vary slightly.

TABLE 5 - CABLE-TROL®

CUT CABLE LENGTH - VS. ASSEMBLY LENGTH FOR CABLE-TROL® This chart is for standard CABLE-TROL® cylinders only - it also can prove helpful in figuring additional cable needed for special applications.

MODEL	CP	CT	PS	TS	SD	CABLE DIA.	STRIP LENGTH	SWAGE ADDER EACH	SCREW ADDER	STROKE + C.C.L.
07	2.06	2.06	1.46	1.44	1.50	3/32	.30	.13	.31	4.88
10	1.68	1.68	1.24	1.44	1.50	3/32	.30	.13	.38	5.00
15	2.06	3.94	1.24	2.94	3.00	3/16	.45	.25	.38	10.88
20	2.06	4.69	1.68	3.44	4.25	1/4	.45	.25	.38	13.88
20P	2.06	5.06	1.68	3.64	4.00	1/4	.45	.25	.38	13.80
25	2.06	4.69	1.68	3.44	4.25	1/4	.45	.25	.38	13.88
25P	2.63	5.94	2.25	4.19	5.00	3/8	.94	.50	.50	17.88
32	2.72	6.03	1.98	4.19	5.31	5/16	.75	.50	.25	17.50
40	2.72	6.03	1.98	4.19	6.00	3/8	.94	.50	.50	20.00
50	3.00	7.00	2.75	5.25	6.00	3/8	.94	.50	.50	20.50

Dimensions in inches

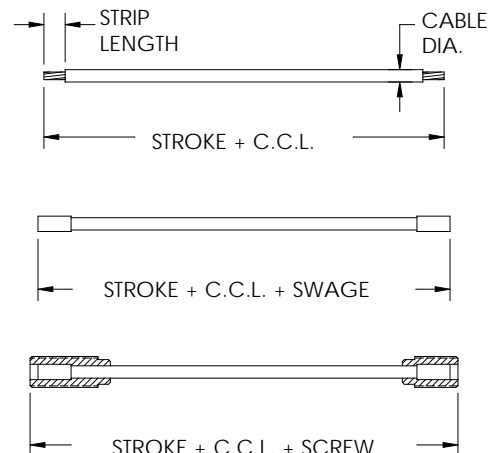
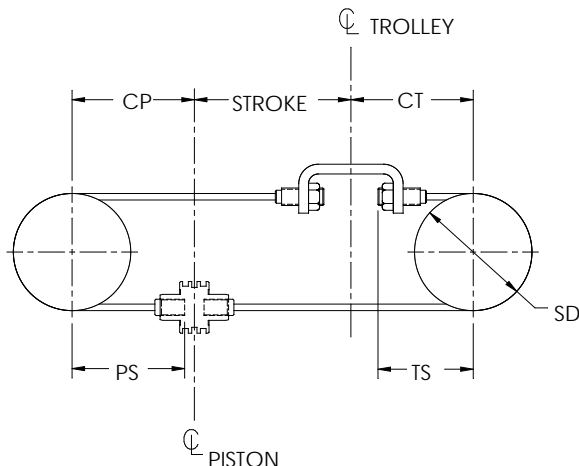

AUTOMATIC TENSIONER (T)

By keeping constant tension on the cable, the automatic tensioner increases both seal and cable life.

To insure that cables will be tensioned properly under any circumstances, we strongly recommend an Automatic Tensioner. The Automatic Tensioner eliminates manual adjustment except for initial installation.

After adjusting Tensioner nut, the cables will remain tight and the unit will automatically compensate for cable stretch. Tensioner is mounted at position 4 on the head.



Does not increase cylinder length • No additional air supply needed.

MODEL	A	B*	C	D	E	F
15	1.00	7.25	10.00	1.88	2.05	3.25
20	1.00	9.03	12.50	2.62	2.55	4.25
25	1.00	9.03	12.50	2.62	2.55	4.50
32	1.00	10.34	14.50	3.31	3.55	5.50
40	1.00	11.60	17.75	3.88	3.05	6.75
50	1.00	11.60	17.75	3.88	3.05	6.75
25P	1.00	11.60	17.75	3.31	3.55	5.12

*After installation
Dimensions in inches

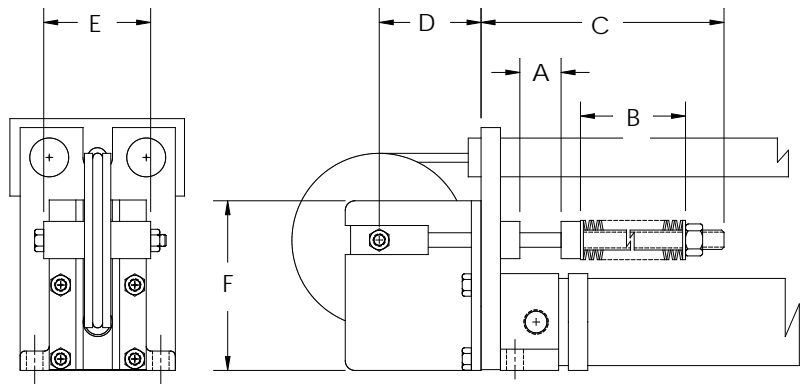

SHEAVE BRACKET ASSEMBLY

Special applications such as remote location or turning corners may require one or more additional sheave bracket assemblies. They are furnished complete, ready for mounting.

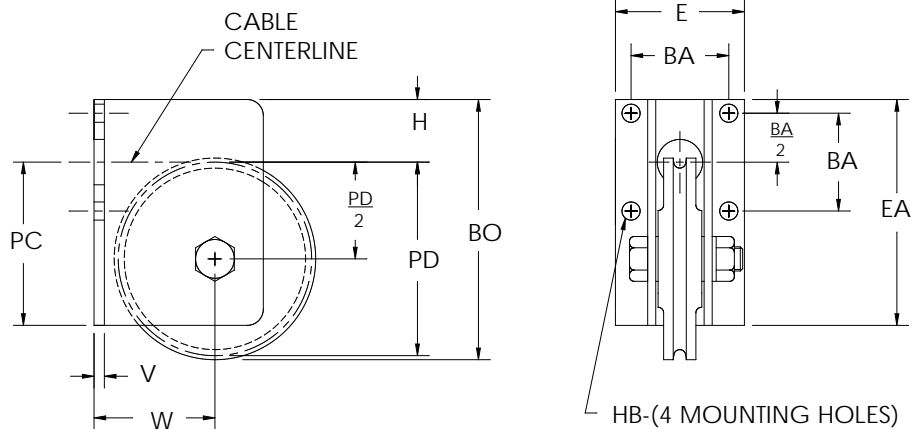

BORE	E	H	EA	BO	HB	PC	PD	PD/2	RS	BA	BA/2	V	W
1.50	2.00	0.97	3.25	4.03	0.28	2.28	3.00	1.50	1.56	1.52	0.76	0.16	1.88
2.00	2.50	1.23	4.25	5.61	0.34	3.02	4.25	2.12	2.25	1.91	0.96	0.25	2.62
2.50	3.00	1.48	4.50	5.86	0.34	3.02	4.25	2.12	2.25	2.41	1.21	0.25	2.62
3.25	3.75	1.83	5.50	7.24	0.41	3.66	5.32	2.66	2.75	2.88	1.44	0.38	3.31
4.00	4.50	2.23	6.73	8.42	0.41	4.50	6.00	3.00	3.19	3.32	1.66	0.38	3.88
5.00	5.50	2.73	6.75	8.92	0.50	4.02	6.00	3.00	3.19	4.10	2.05	0.50	4.00

Dimensions in inches.

CABLE ATTACHMENTS FOR CABLE-TROL

Certain applications may require special accessories as indicated. Where standard trolleys will not carry load properly our optional cable end accessories are offered.

These can be ordered on new units or can be field installed since they utilize a "manual swage" and are available in Models 15 through 50.

STUD SOCKET ASSEMBLY

CYL BORE	SF	SG	SC	THREAD	SJ	SK	SH
1.50	1.88	0.12	3.50	0.25-28	0.56	0.25	0.39
2.00	2.19	0.12	4.19	0.38-24	0.69	0.38	0.44
2.50	2.19	0.12	4.19	0.38-24	0.69	0.38	0.44
3.25	2.19	0.12	4.19	0.38-24	0.69	0.38	0.44
4 & 5	4.55	0.19	7.05	0.50-20	0.88	0.50	0.58

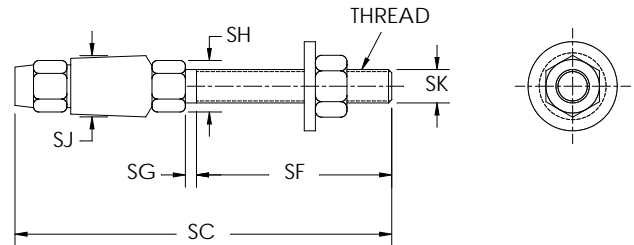

CLEVIS SOCKET ASSEMBLY

CYL BORE	CX	CJ	CH	CM	CQ	CZ	CN
1.50	0.31	0.50	2.44	0.62	0.25	0.25	0.81
2.00	0.38	0.62	2.97	0.75	0.31	0.31	0.94
2.50	0.38	0.62	2.97	0.75	0.31	0.31	0.94
3.25	0.38	0.62	2.97	0.75	0.31	0.31	0.94
4 & 5	0.47	0.75	3.72	0.94	0.38	0.38	1.12

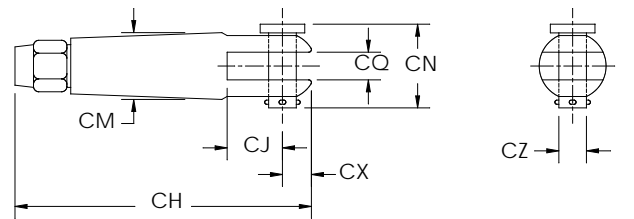

EYE SOCKET ASSEMBLY

CYL BORE	EK	EJ	EH	ED	EG	EF	EM
1.50	0.34	0.44	2.47	0.62	0.23	0.27	0.19
2.00	0.41	0.56	3.00	0.75	0.30	0.33	0.22
2.50	0.41	0.56	3.00	0.75	0.30	0.33	0.22
3.25	0.41	0.56	3.00	0.75	0.31	0.33	0.22
4 & 5	0.50	0.81	3.75	0.94	0.36	0.39	0.28

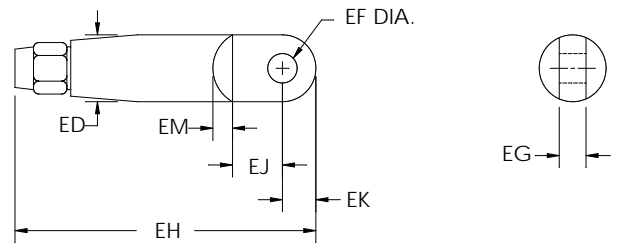

"H" TROLLEY STYLE "H" TROLLEY IS STANDARD ON MODEL 50.

THE "H" IS OPTIONAL ON MODELS 15, 20, 20P, 25, 25P, 32 AND 40.

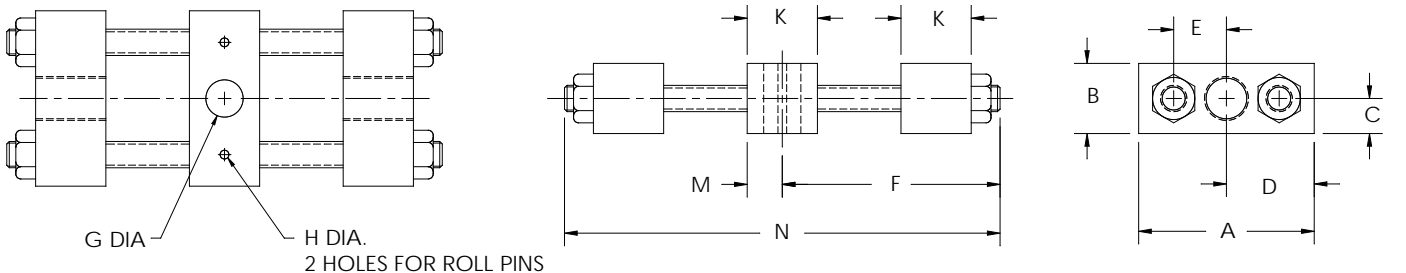

MODEL	A	B	C	D	E	F	G	H	K	M	N
15	1.75	.75	.375	.875	.625	2.50	.31	.094	.75	.375	4.00
20, 25	1.75	.75	.375	.875	.625	2.50	.31	.094	.75	.375	4.75
20P	2.50	1.00	.50	1.25	.800	3.00	.53	.125	1.00	.50	6.00
32, 40, 25P	3.00	1.25	.625	1.50	1.00	3.50	.56	.156	1.25	.625	7.125
50	3.00	1.25	.625	1.50	1.00	3.50	.68	.156	1.25	.625	7.125

Dimensions in inches



DESCRIPTION

Greenco's Reed Switch consists of a hermetically sealed glass capsule containing two cantilevered ferromagnetic blades. The blades come together and close the electrical circuit whenever the magnet, mounted on the piston, passes under the response area of the switch. An integral arc suppressing resistor-capacitor circuit protects blade contacts from voltage spikes, thereby extending cycle life. The lead wires are shielded to protect against sending or receiving induced currents as false signals. The shield may be "drained" using uninsulated third wire. An ohmmeter is recommended to test the switch function. DO NOT USE an incandescent light bulb as high in-rush may damage the switch. Be sure to connect the reed switch to the power source through a load. Direct connection of the switch may cause damage to the internal elements of the switch. To prevent electric shock, always shut off power supply before handling electric wire leads. The comprehensive design of the cylinder barrel thickness and mass of magnet, coupled with low profile switch provides sensitivity, dependability, repeatability and desired response time. PROXIMITY and GO® switches also available. Contact factory for additional information.

INCREASED LENGTH WITH END STROKE SENSING

MODEL	07	10	15	20	25	20P	25P	32	40	50
CABLE-TROL®	1-5/8"	1-5/8"	2"	2"	2"	2"	2"	2"	2"	2" *
TRAC-TROL®	N/A	0"	2"	0"	0"	0"	0"	0"	0"	0"

IMPORTANT NOTE: For **END STROKE SENSING**, Reed switch package will increase mounting dimensions by 1-5/8" on Cable-Trol® Models 07 & 10 and by 2" on all other Cable-Trols and Model 15 Trac-Trol®.

REED SWITCH SPECIFICATIONS

- Voltage Rating: 200 V Max AC or DC
- Switch Current: 1A Max AC or DC
- Switching Power - 30 Watts
- Contact Type - Form A, N.O.
- Single Pole, Single Throw Initial Contact Resistance: 0.1ohms
- Minimum Breakdown Voltage: 275 VAC or 225 VDC
- Temperature Range: 32°F to 150°F
- Lead Wire Length - 9 ft.
- Actuation Repeatability: ± .005 in.
- Switch Materials: Stainless Steel and Nylon
- Reed Switches are available on all models of Cable-trol® and Trac-trol®.

* Model 50 Cable-trol® can achieve end stroke sensing without any increased length, consult factory.

OPTIONAL ACCESSORIES

LINEAR BEARINGS FOR THE TRAC-TROL® TROLLEY

The Trac-trol® trolley contains four independent linear bearings for maximum load bearing capabilities. Each standard bearing contains a set of continuously re-circulating precision steel balls for low friction and superior wear resistance. The load is actually being rolled freely along the two hardened steel guide rods. Optional stainless steel guide rods and self lubricating polymeric linear bearings are also available (consult factory.)



20C REPAIR KIT



The 20C repair kit consists of two cable subassemblies and all the seals for any one model of Cable-Trol® or Trac-Trol® cylinder. When ordering you must specify the complete model number and serial number of the unit the repair kit is to be used on.

air/oil tank

FEATURES & DIMENSIONS



HOW TO ORDER

1. Refer to Table 1, on page 5 to find effective area (square inch) of cylinder.
2. Multiple effective area by stroke of cylinder to determine volume.
3. **IMPORTANT:** Multiply area by 1.5 **safety factor.**
4. Select Air/Oil tank capacity closest to volume.
See capacity chart below.

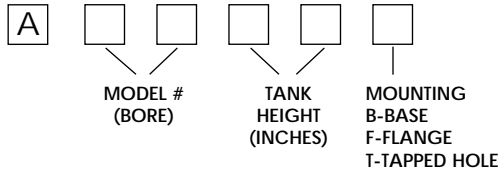

EXAMPLES:

CD2511A
 (Effective area of Model 25)4.8597
 (Stroke)x 11
 53.45
 (Safety Factor.....x 1.5
 80.19

Base your selection on space requirement and port size (for high speed).

Depending on space available, the customer could select A2517T, A3210T, A4007T, A5004T or A6003T.

OPTIONAL BASE & FLANGE MOUNT

BORE	C	FB	FH	J	RE	SB	THK.	TF	TS	UF	US
2.50	1.250	3/8	3/8	1	2.190	7/16	3/8	3 7/8	3 3/4	4 5/8	4 1/2
3.25	1.500	7/16	5/8	1 1/4	2.760	9/16	1/2	4 11/16	4 3/4	5 1/2	5 3/4
4.00	2.062	7/16	5/8	1 1/4	3.320	9/16	1/2	5 7/16	5 1/2	6 1/4	6 1/2
5.00	2.688	9/16	5/8	1 1/4	4.100	5/8	3/4	6 5/8	6 7/8	7 5/8	8 1/4
6.00	3.250	9/16	3/4	1 1/2	4.880	3/4	1	7 5/8	7 7/8	8 5/8	9 1/4
8.00	4.500	N/A	N/A	1 1/2	N/A	3/4	1	N/A	9 7/8	N/A	11 1/4

Tolerance on Overall Height: ± 1/16" On Fractions
 ± .010 On 3 Place Decimals
 Dimensions in inches

OPTIONAL BASE MOUNT (TYP. TOP & BOTTOM)

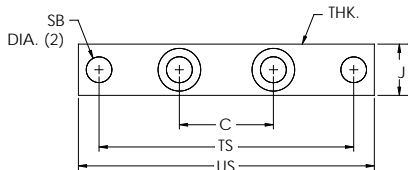

OPTIONAL FLANGE MOUNT (NOTE: FLANGE ADDS TO OVERALL HEIGHT)

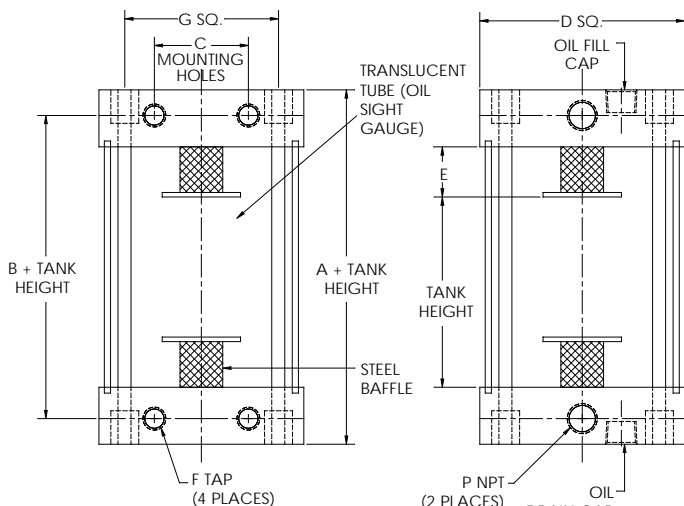
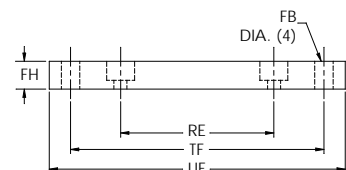

TRANSLUCENT TUBING DESIGN

NOTE: 200° F
 MAX. OPERATING
 TEMPERATURE
 150 PSI MAX.



Greenco's air over oil tank is the ideal answer for your power requirements where smooth, even hydraulic action is required. This lightweight, compact unit is easily installed on any existing or new application. Years of worry-free, inexpensive operation are virtually guaranteed, because there are no moving parts.

TAPPED HOLE MOUNT (STANDARD)

BORE	VOLUME (PER IN.)	A	B	C	D	E	F	G	P NPT
2.50	4.91 cu. in.	3 5/32	2 9/32	1.250	3.000	1 1/8	3/8-16" x .625"	2.190	3/8
3.25	8.30 cu. in.	3 17/32	2 13/32	1.500	3.750	1	1/2-13" x .750"	2.760	1/2
4.00	12.57 cu. in.	3 17/32	2 13/32	2.062	4.500	1	1/2-13" x .750"	3.320	1/2
5.00	19.64 cu. in.	3 17/32	2 13/32	2.688	5.500	1	5/8-11" x 1.00"	4.100	1/2
6.00	28.27 cu. in.	4 1/32	2 21/32	3.250	6.500	1	3/4-10" x 1.125"	4.880	3/4
8.00	50.26 cu. in.	4 1/32	2 21/32	4.500	8.500	1	3/4-10" x 1.125"	6.440	3/4

NOTE: Flange & base mounting available at extra cost.
 Dimensions in inches

USABLE OIL CAPACITY CHART (cu. in.)

TANK HEIGHT WITH USEABLE OIL CAPACITY IN CUBIC INCHES	MODEL NUMBERS					
	A-25	A-32	A-40	A-50	A-60	A-80
	TANK BORE SIZE (INCHES)					
	2 1/2"	3 1/4"	4"	5"	6"	8"
1"	5	8	12	20	28	50
2"	10	16	25	39	56	100
3"	15	25	37	59	84	150
4"	19	33	50	78	112	199
5"	24	41	62	98	140	249
6"	29	49	75	117	168	299
7"	34	58	87	137	197	349
8"	39	66	100	156	225	399
9"	44	74	112	176	253	449
10"	48	82	125	195	281	499
11"	53	90	137	215	309	549
12"	58	99	149	234	337	598
13"	63	107	162	254	365	648
14"	68	115	174	273	393	698
15"	73	123	187	293	421	748
16"	78	132	199	312	449	798
17"	82	140	212	332	477	848

NOTE: TANK HEIGHTS ARE NOT LIMITED TO 17". TANK HEIGHTS UP TO 10 FT. ARE POSSIBLE.

STANDARD FEATURES

MODELS 07 - 10

- Extruded aluminum heads
- Fixed cushions.
- One piece "C" Trolley.
- Aluminum sheaves with steel needle bearings.
- Precision aluminum piston.
- Aluminum hard-coated tubes or optional steel tubes (special plating available).
- Nylon coated aircraft type steel cable (heavy duty cable is available).
- Air and oil use up to 150 psi.
- 1/8" NPT ports.
- Optional reed switch package available, see page 10.

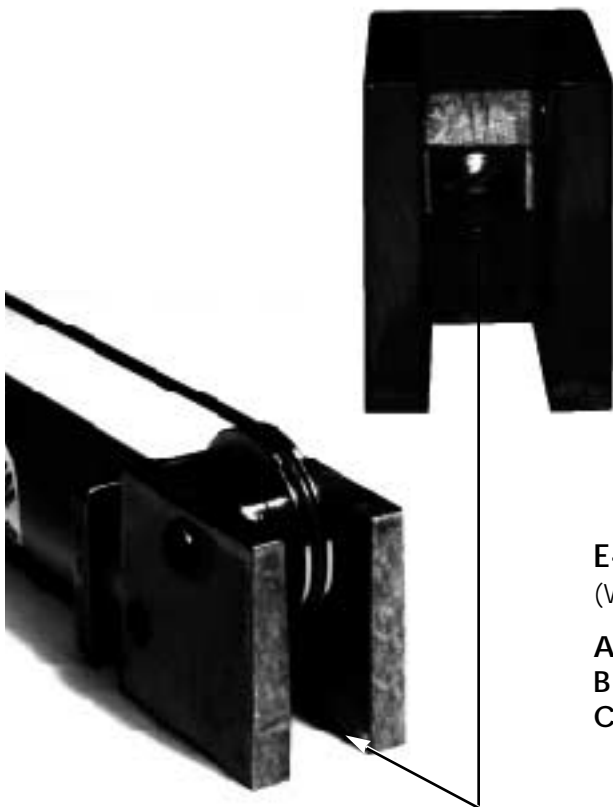

EXCLUSIVE E-Z LOCKSEAL™

Greenco's exclusive zinc plated steel E-Z LOCKSEAL™ provides a POSITIVE LOCK & SEAL which will help prevent accidental "bursting". A standard screwdriver is all that is needed to remove or replace. No retaining rings necessary.

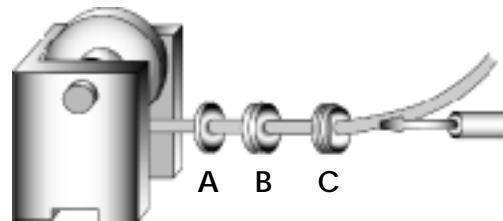

E-Z lockseal™ (WITH SCREWDRIVER SLOT)

- A Gasket
- B Urethane Cable Seal
- C Zinc plated steel E-Z LOCKSEAL™
Provides positive lock and seal which cannot accidentally pop-out.



DOUBLE END - CD

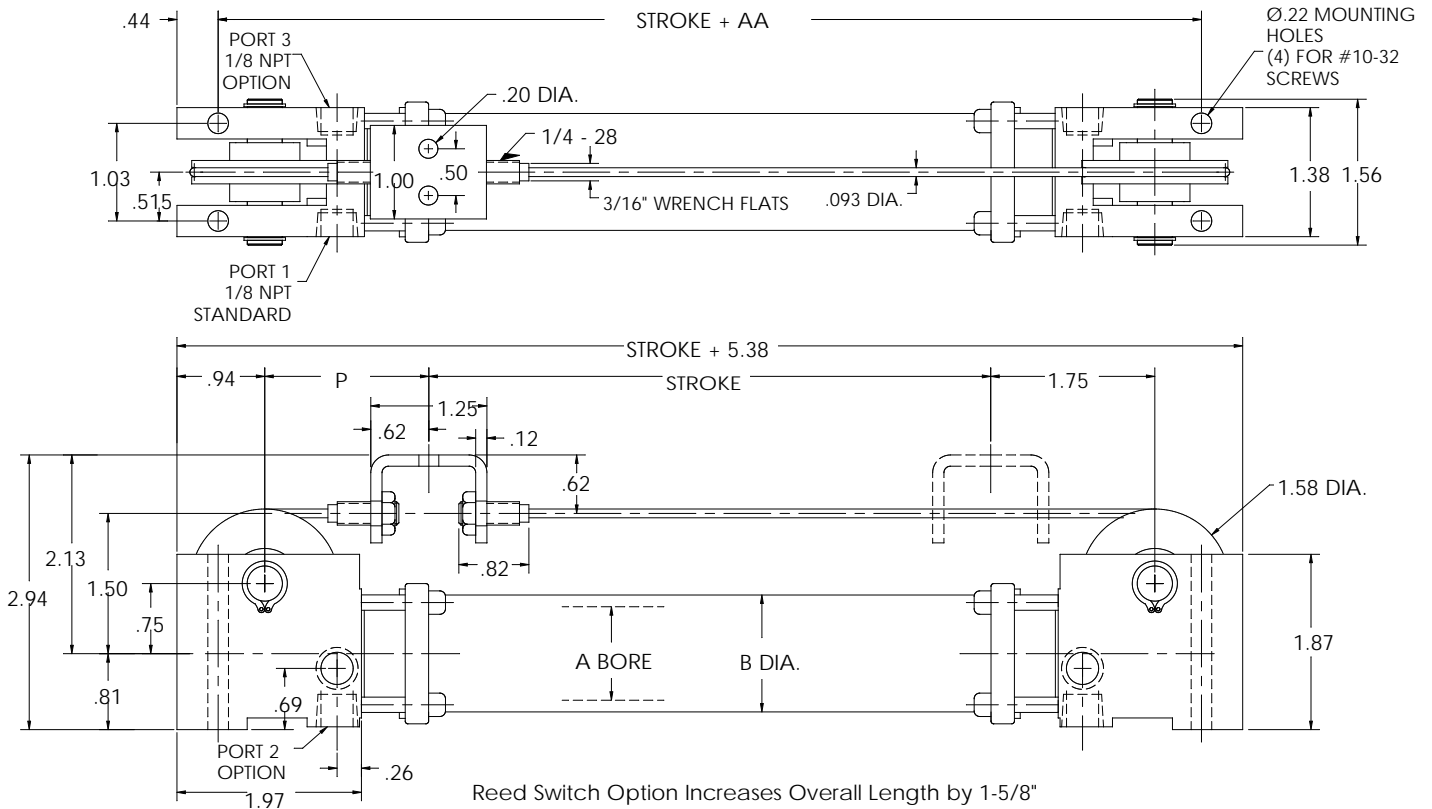

SINGLE END - CS

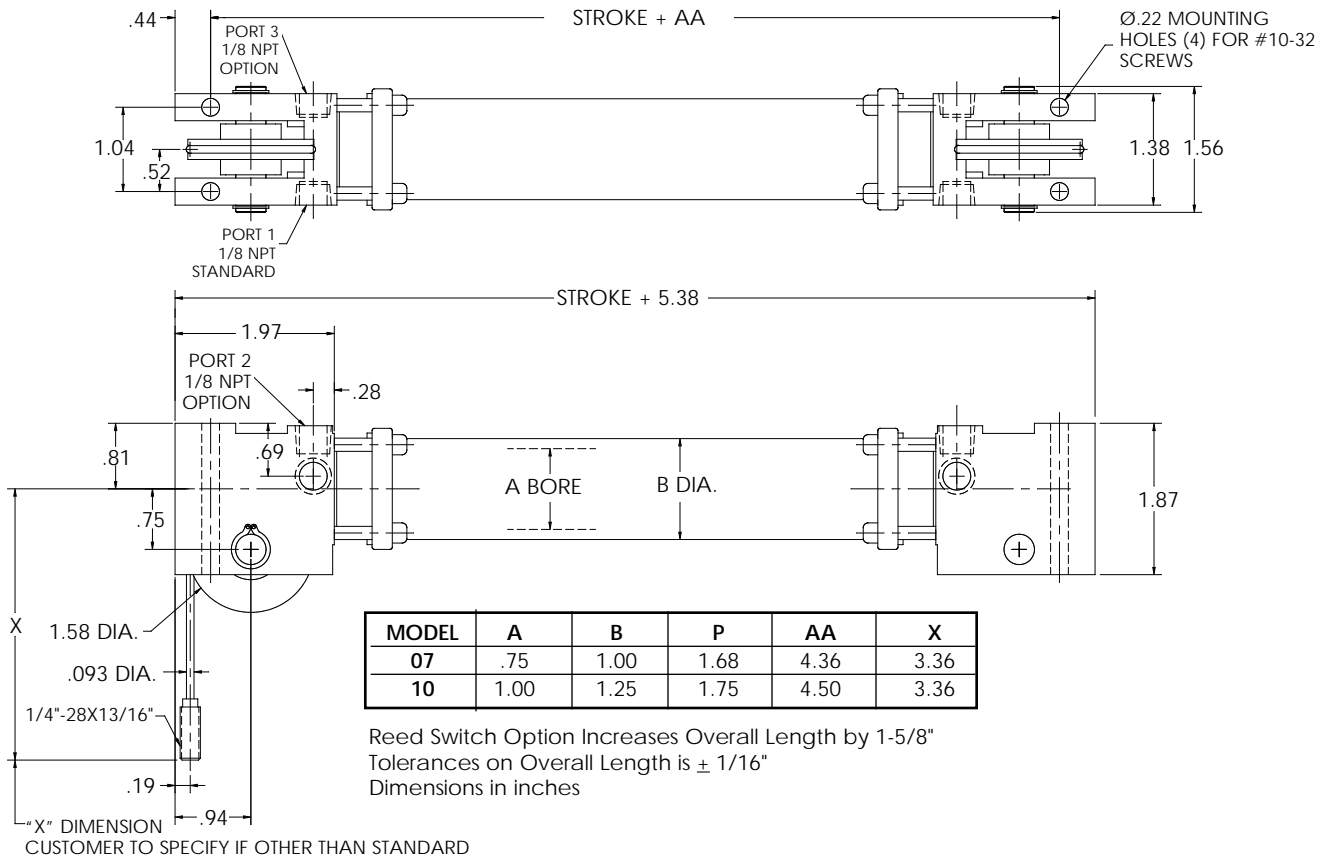

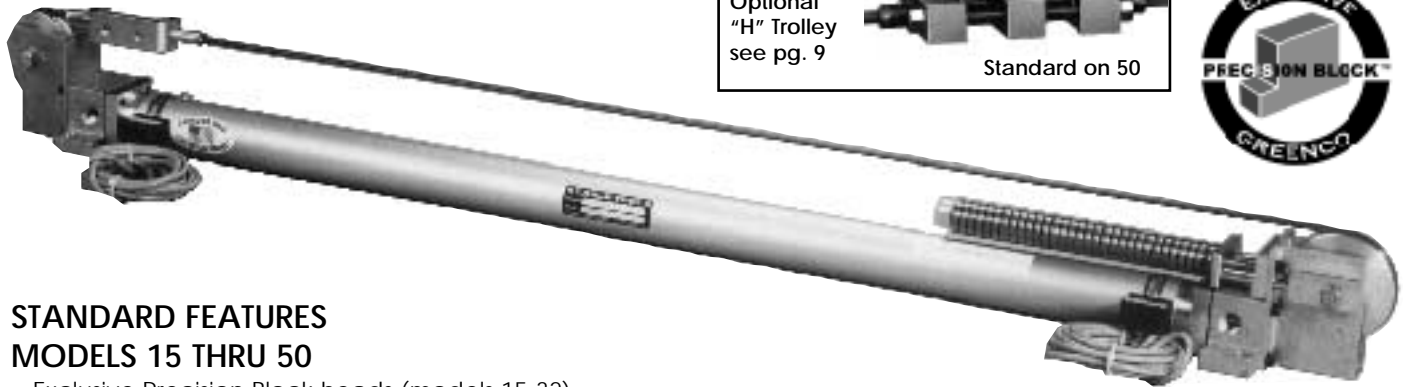

Optional
"H" Trolley
see pg. 9



Standard on 50



STANDARD FEATURES MODELS 15 THRU 50

- Exclusive Precision Block heads (models 15-32), extruded square aluminum heads with rectangular aluminum mount bar (models 40-50).
- Adjustable cushions.
- One piece "C" Trolley standard on models 07-40. "H" trolley optional on models 15-40, "H" trolley standard on Model 50.
- Aluminum sheaves with steel needle bearings.
- Precision aluminum piston.
- Aluminum hard-coated tubes or optional steel tubes (special plating available).
- Nylon coated aircraft type steel cable (heavy duty cable is available).
- Air and oil use up to 150 psi.
- Optional SAE and Metric BSP ports available.
- Optional reed switch package available, see page 10.
- Symmetrically attached sheave bracket can be rotate in 4 directions.

HIGH PRESSURE UNITS AVAILABLE

NOTE: Hydraulic and High Pressure Hydraulic units are equipped with seals that are compatible for most all mineral and petroleum base hydraulic fluids. Consult factory for special fluid compatibility ratings.



MODEL 20P (2 ") FEATURES:

- Hydraulic Service up to 500 PSI Non-shock*.
- Extruded Aluminum Sheaves with ball bearings.
- Extruded Aluminum Sheave Bracket.
- Heavy Duty C Trolley.
- Hard Coated Aluminum or Steel Tube.



MODEL 25P (2 1/2 ") FEATURES:

- Hydraulic Service up to 500 PSI Non-shock*.
 - Heavy Duty "C" Trolley & Sheave-Bracket Assembly
 - Fixed Cushions.
 - Hard-Coated Aluminum or Steel Tube
- *300 PSI maximum for shock or pressure spike applications.

DOUBLE END - CD

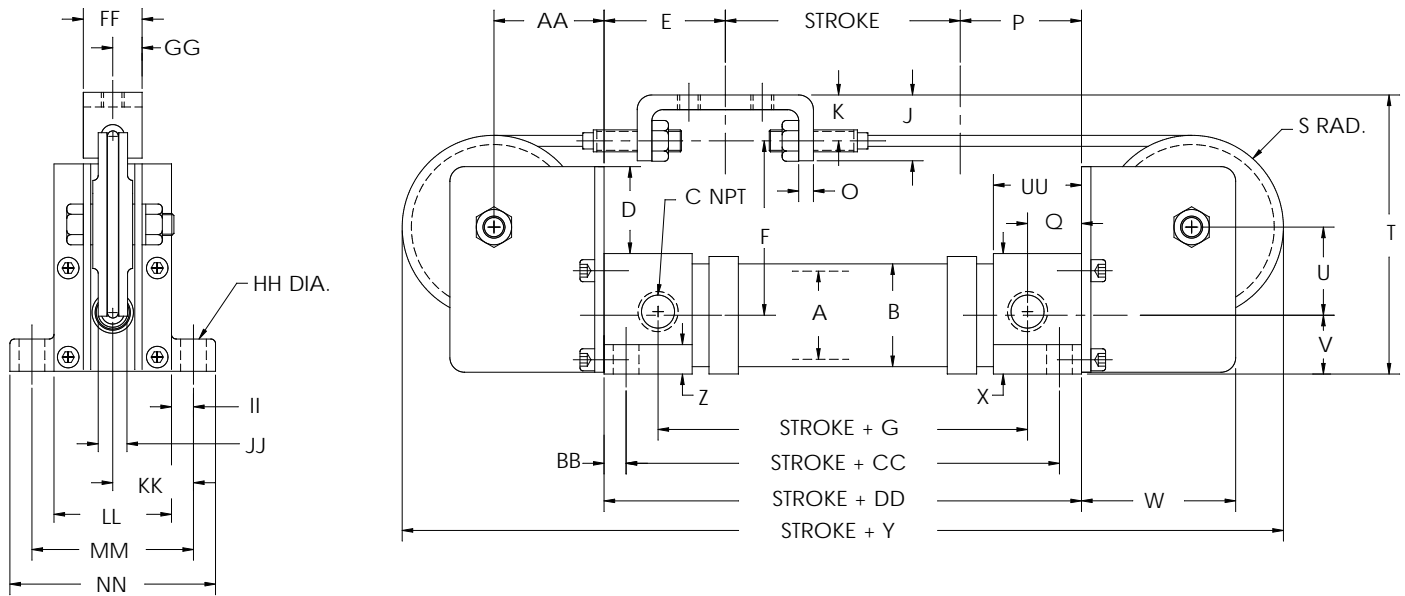
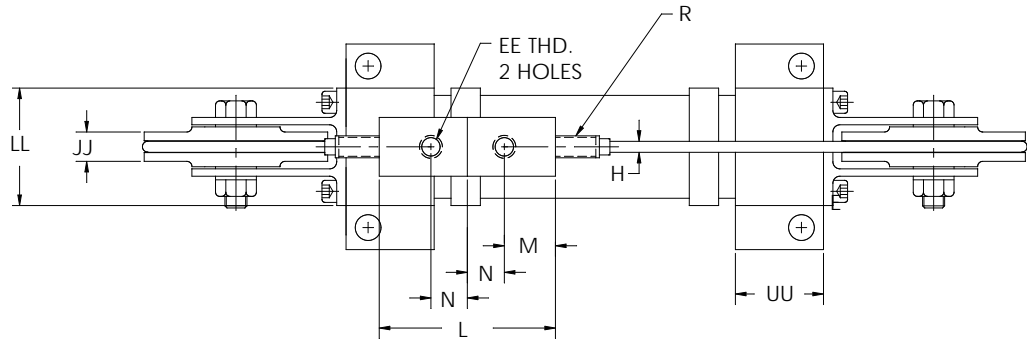

MODEL	A	B	C	D	E	F	G	H	J	K	L	M	N	O	P	Q	R	S	T	U	V	W	X	Y	Z
15	1.50	1.75	3/8	1.48	2.06	3.00	2.31	.18	1.12	.75	3.00	.88	.62	.25	2.06	.91	3/8-24 x 1.68	1.59	4.75	1.50	1.00	2.62	2.00	11.06	.50
20	2.00	2.25	3/8	1.88	2.06	4.25	2.31	.25	1.88	1.25	4.00	1.00	1.00	.38	2.06	.91	5/8-18 x 1.63	2.25	6.75	2.12	1.25	3.50	2.50	13.88	.50
25	2.50	2.75	3/8	1.52	2.06	4.25	2.31	.25	1.88	1.25	4.00	1.00	1.00	.38	2.06	.91	5/8-18 x 1.63	2.25	7.00	2.12	1.50	3.50	3.00	13.86	.50
32	3.25	3.50	1/2	1.88	2.72	5.31	3.12	.31	1.88	1.25	5.25	1.62	1.00	.38	2.72	1.03	3/4-16 x 2.25	2.81	8.44	2.66	1.88	4.32	3.75	17.68	.75
40	4.00	4.25	1/2	2.27	2.72	6.00	3.38	.38	1.88	1.25	5.25	1.62	1.00	.38	2.72	1.03	3/4-16 x 2.50	3.19	9.50	3.00	2.25	5.38	4.50	19.58	.88
20P	2.00	2.25	3/8	1.88	2.06	4.00	2.31	.25	1.88	1.25	5.25	1.62	1.00	.38	2.06	.91	5/8-18 x 1.63	2.12	6.49	2.00	1.24	3.62	2.50	14.36	.50
25P	2.50	2.75	3/8	2.12	2.78	5.31	3.75	.38	1.88	1.25	5.25	1.62	1.00	.38	2.78	.91	3/4-16 x 2.50	2.84	8.06	2.66	1.50	4.32	3.00	17.88	.50

MODEL	AA	BB	CC	DD	EE	FF	GG	HH	II	JJ	KK	LL	MM	NN	UU
15	1.88	.38	3.38	4.12	3/8-16	1.00	.50	.44	.38	.50	1.38	2.00	2.75	3.50	1.50
20	2.62	.38	3.38	4.12	3/8-24	1.50	.75	.44	.38	.68	1.62	2.50	3.25	4.00	1.50
25	2.62	.38	3.38	4.12	3/8-24	1.50	.75	.44	.38	.68	1.88	3.00	3.75	4.50	1.50
32	3.31	.50	4.44	5.44	3/8-24	2.00	1.00	.56	.50	.68	2.38	3.75	4.75	5.75	1.75
40	3.88	.50	4.44	5.44	3/8-24	2.00	1.00	.56	.50	.86	2.75	4.50	5.50	6.50	1.75
20P	3.00	.38	3.38	4.12	3/8-24	2.00	1.00	.44	.38	.62	1.62	2.50	3.25	4.00	1.50
25P	3.31	.38	4.81	5.56	3/8-24	2.00	1.00	.44	.38	.68	1.88	3.00	3.75	4.50	1.50

Dimensions in inches

Tolerance on Overall Length is $\pm 1/16"$

Reed Switch Option Increases Overall Length by 2"

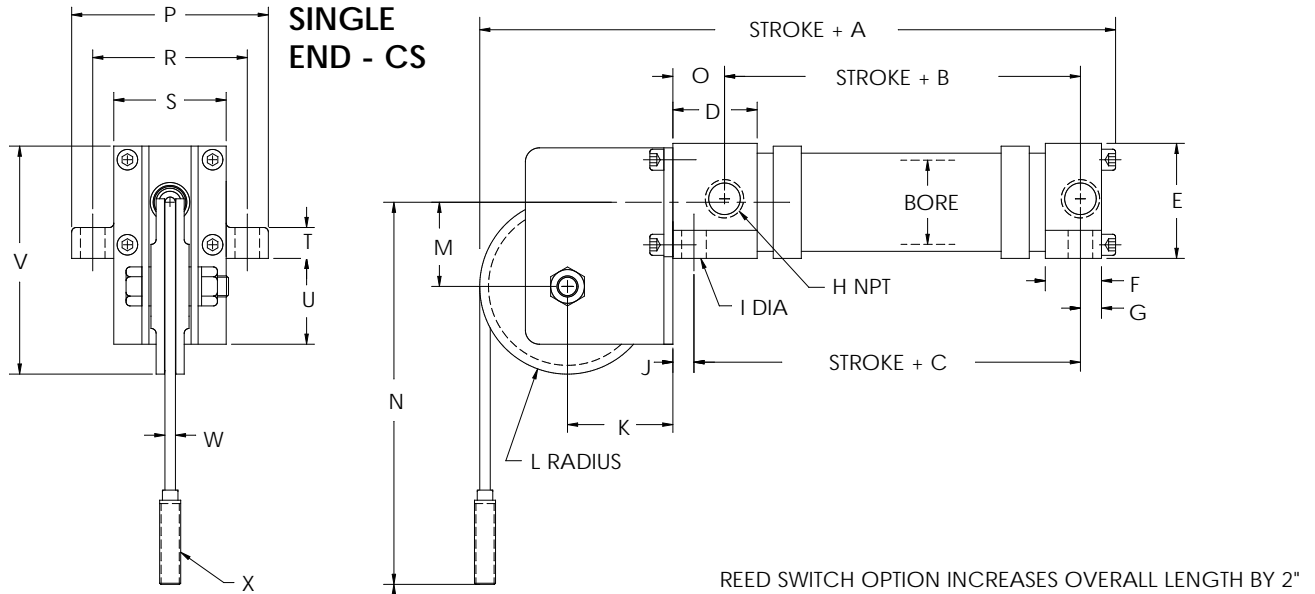

Dimensions in inches
Tolerance on Overall Length is $\pm 1/16$ "

NOTE: N - Dimensions customer to specify if other than standard.

MODEL	BORE	A	B	C	D	E	F	G	H	I	J	K	L	M	N	O	P	R	S	T	U	V	W	X
15	1.50	7.34	2.31	2.88	1.50	2.00	1.00	.38	3/8	.44	.38	1.88	1.59	1.50	6.81	.91	3.50	2.75	2.00	.50	1.25	4.08	.18	3/8-24 x 1.69
20	2.00	8.86	2.31	2.83	1.50	2.50	1.00	.38	3/8	.44	.38	2.62	2.25	2.12	8.88	.91	4.00	3.25	2.50	.50	1.75	5.62	.25	5/8-18 x 1.63
25	2.50	8.86	2.31	2.88	1.50	3.00	1.00	.38	3/8	.44	.38	2.62	2.25	2.12	8.88	.91	4.50	3.75	3.00	.50	1.50	5.88	.25	5/8-18 x 1.63
32	3.25	11.50	3.12	3.94	1.75	3.75	1.25	.50	1/2	.56	.50	3.31	2.81	2.66	11.00	1.03	5.75	4.75	3.75	.75	1.75	7.24	.31	3/4-16 x 2.25
40	4.00	12.45	3.38	3.94	1.75	4.50	1.25	.50	1/2	.56	.50	3.88	3.19	3.00	12.25	1.03	6.50	5.50	4.50	.88	2.25	8.44	.38	3/4-16 x 2.50
20P	2.00	9.10	2.31	2.83	1.50	2.50	1.00	.38	3/8	.44	.38	3.00	2.12	2.00	8.50	.91	4.00	3.25	2.50	.50	1.38	5.36	.25	5/8-18 x 1.63
25P	2.50	9.98	3.75	4.32	1.50	3.00	1.00	.38	3/8	.44	.38	3.31	2.66	2.66	11.16	.91	4.50	3.75	3.00	.50	2.12	6.82	.38	3/4-16 x 2.50

TUBE SUPPORT

The tube support is available for all models of Cable-Trol® and Trac-Trol® Cylinders. We recommend it for all units that have a stroke over 6 ft.

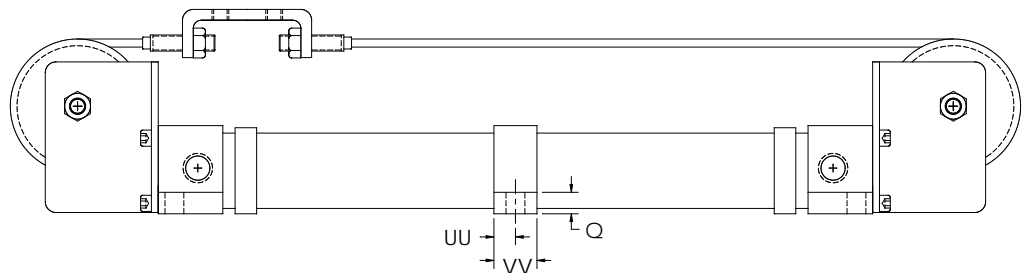
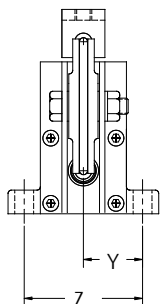
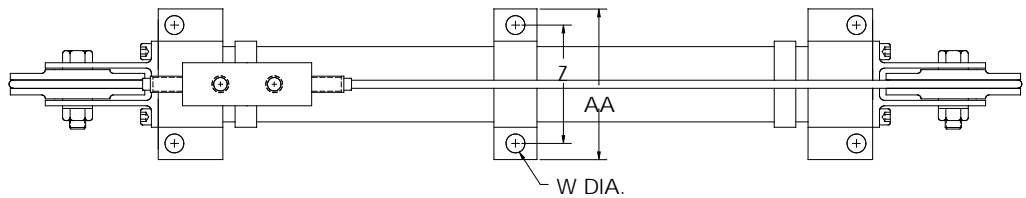

MODEL	AA	Q	W DIA.	Y	Z	UU	VV
115-03406	3.50	.50	.44	1.38	2.75	.50	1.00
120-03406	4.00	.50	.44	1.62	3.25	.63	1.25
120-03406	4.00	.50	.44	1.62	3.25	.63	1.25
125-03406	4.50	.50	.44	1.88	3.75	.63	1.25
125-03406	4.50	.50	.44	1.88	3.75	.63	1.25
132-03406	5.75	.75	.56	2.38	4.75	.75	1.50
140-03406	6.50	1.00	.56	2.75	5.50	.75	1.50
150-03406	8.25	1.00	.81	3.44	6.87	.75	1.50

Dimensions in inches

MODEL 50 CD DOUBLE END

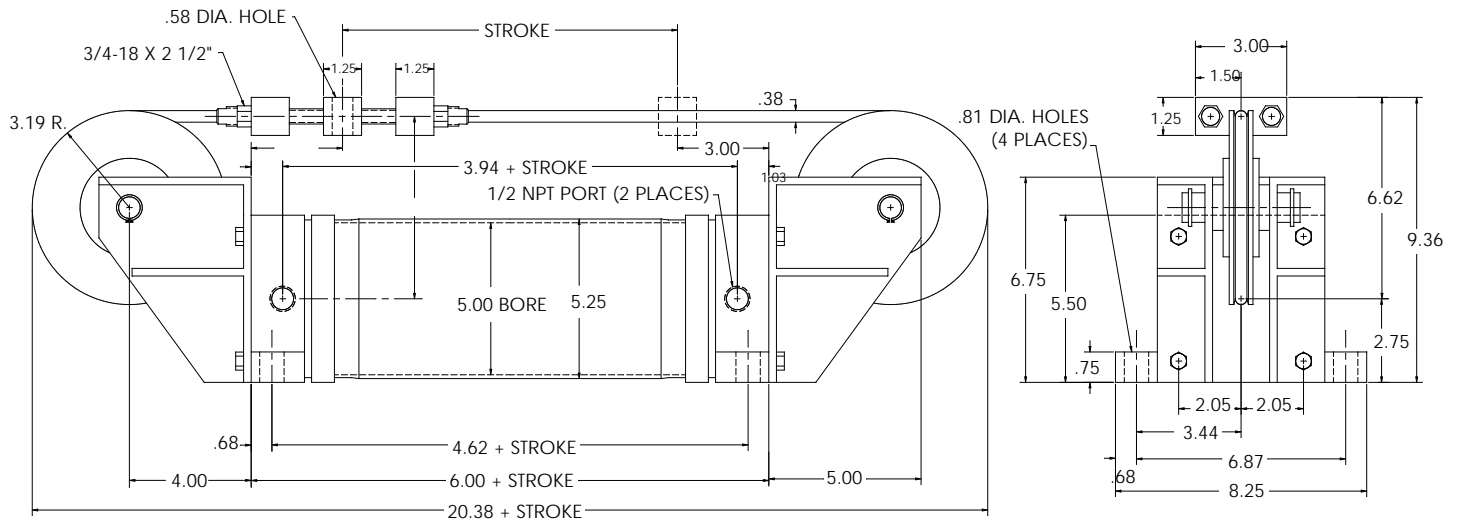

Position Shown on Drawing:
 CD - Standard Side Port at 2, 4 and Sheave at Position 1
 CS - Standard Side Port at 2, 4 and Sheave at Position 3
 REED SWITCH OPTION INCREASES OVERALL LENGTH BY 2"

MODEL 50 CS SINGLE END

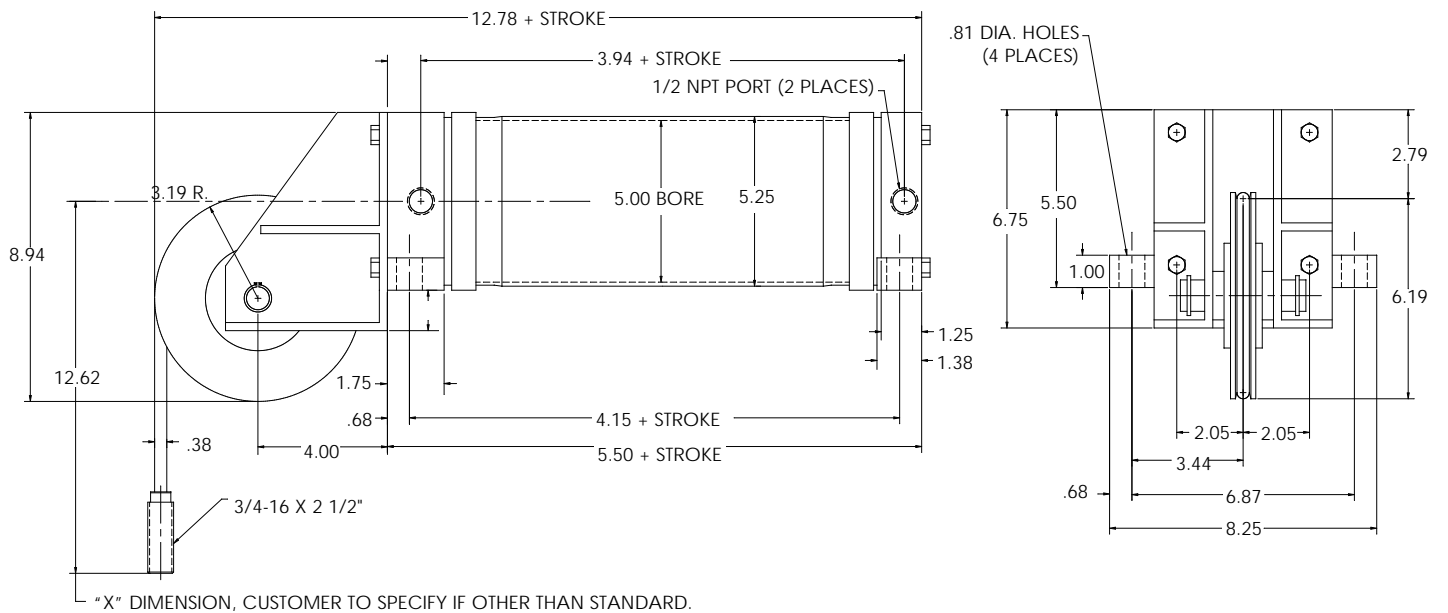

Dimensions in inches
 Tolerance on Overall Length is $\pm 1/16$ "

Trac-Trol® combines linear ball bearings in a trolley which runs on hardened and ground shafts.

SUPPORTED TRAC-TROL® SHOWN (MODEL TS)

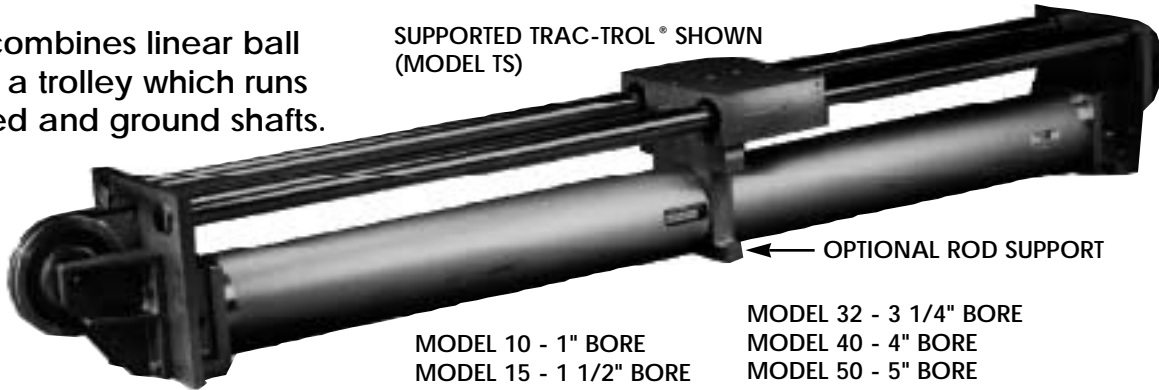

MODEL 10 - 1" BORE
MODEL 15 - 1 1/2" BORE
MODEL 20 - 2" BORE
MODEL 25 - 2 1/2" BORE

MODEL 32 - 3 1/4" BORE
MODEL 40 - 4" BORE
MODEL 50 - 5" BORE
MODEL 20P - 2" BORE HIGH PRESSURE
MODEL 25P - 2 1/2" BORE HIGH PRESSURE

FEATURES

- Air or hydraulic service for smooth operation and precise control.
- Nylon-covered, aircraft-type cable for extra long life.
- Optional low cost rod & cable wipers.
- Extremely small effective sealing area compared to band cylinders for longer working life and ideal for use in "dusty" applications.
- Greater bearing surface for larger capacities.

- Reed switches available.
- Aluminum hardcoated tubes standard or optional steel tube (special plating available).
- Pre-delivery testing and "break-in" to insure customer satisfaction.

LUBRICATION

Generally speaking TRAC-TROL® trolleys don't need lubrication. To insure maximum life, all pneumatic cylinders should be supplied with filtered and lubricated air.

LOADING

Many applications of the TRAC-TROL® cable cylinder involve mounting some of the weight off the side of the unit. To be certain the correct size TRAC-TROL® is used in your specific application use the following equations to compare the calculated load to the curves on the Load vs. Stroke graph which shows the maximum load allowed for a given stroke. Do not exceed the maximum load limit.

LOAD = $F_s + F_p$ where F_s = Reaction force due to side loads.
 F_p = Reaction force due to push/pull loads.

$$F_s = \frac{W(2L + R)}{R}$$

W: weight (lbs.)
L: distance from trolley centerline to center of gravity of weight (inches)
R: see chart below

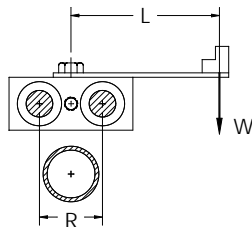

$$F_p = \frac{P(H + h)}{B}$$

P: push/pull force (lbs.)
H: height from trolley surface.
h, B: see chart below

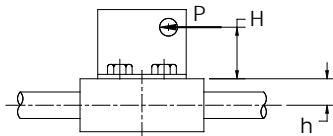

MODEL	R	h	B
T10	1.39	.63	1.25
T15	1.78	.75	1.63
T20, T25	2.50	1.00	2.31
T20P, T25P, T32, T40	3.25	1.25	2.63
T50	7.00	1.50	4.00

Dimensions in inches

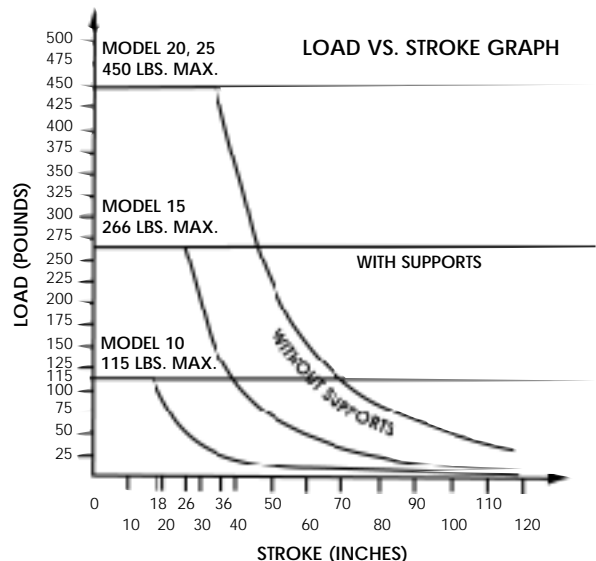
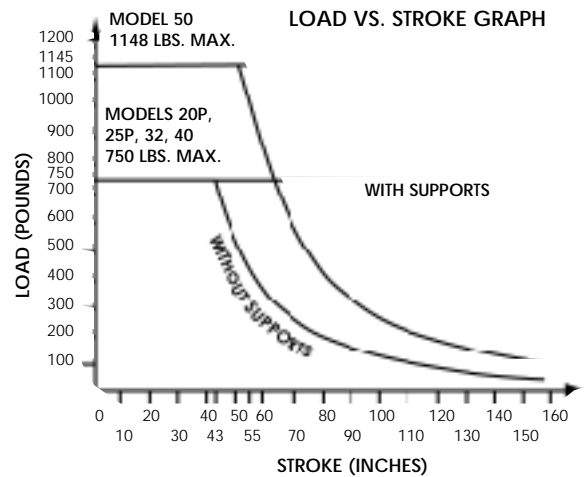

MODEL 10 TRAC-TROL® SUPPORTED

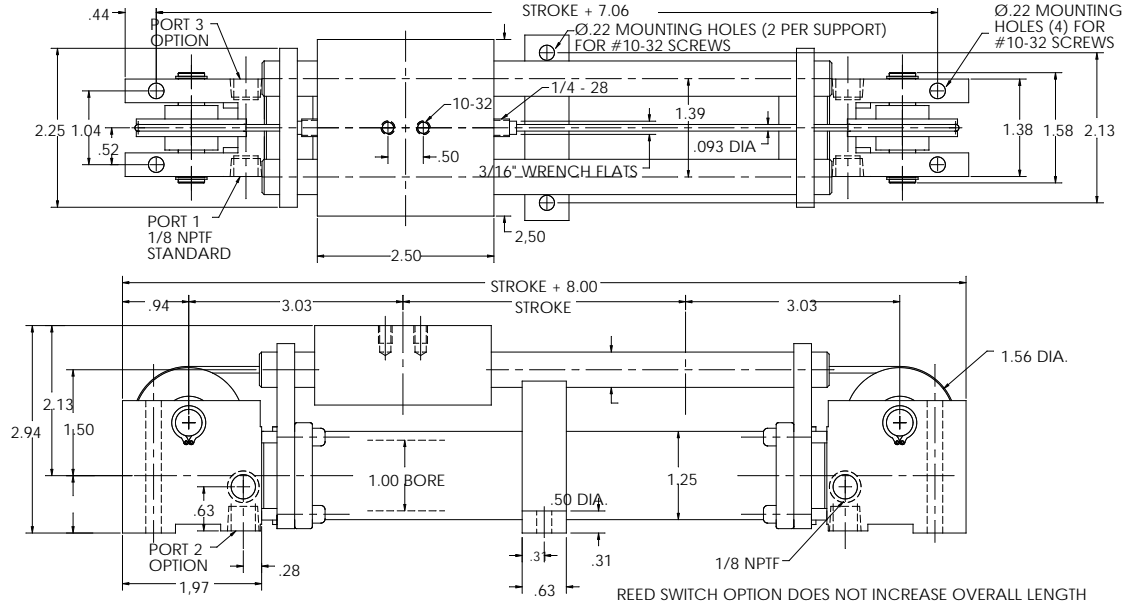

MODEL 15, 20, 20P, 25, 25P, 32, 40 and 50

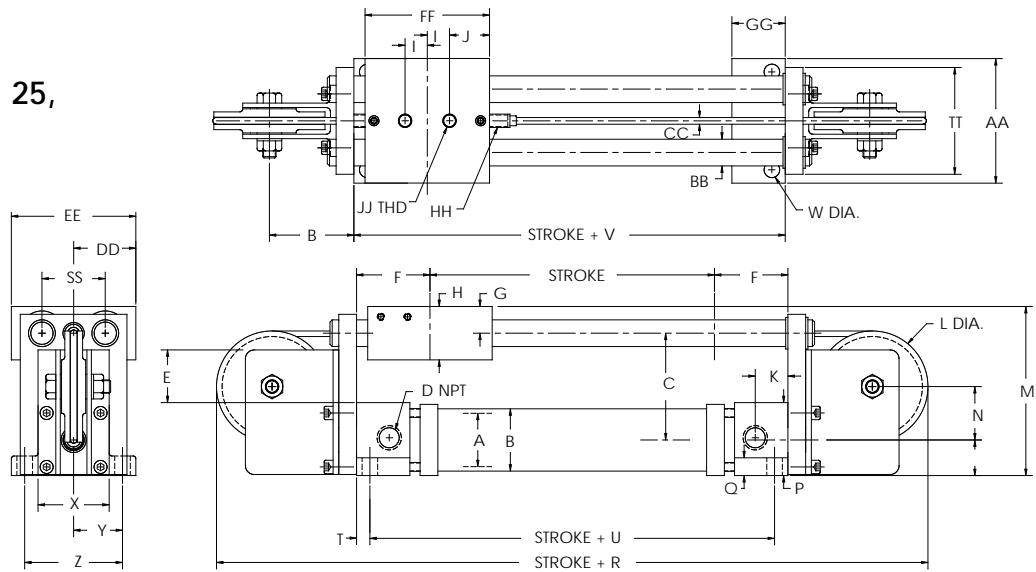

FOR MODEL 15 TRAC-TROL® REED SWITCH OPTION INCREASES OVERALL LENGTH BY 2".

MODEL	A	B	C	D	E	F	G	H	I	J	K	L	M	N	O	P	Q	R	S	T	U	V	W	X	Y	Z
T15	1.50	1.75	3.00	3/8	1.48	2.06	.75	1.50	.63	1.13	.92	3.13	4.75	1.50	1.00	2.00	.50	12.00	2.38	.38	3.38	4.13	.44	2.00	1.38	2.75
T20	2.00	2.25	4.25	3/8	1.88	3.09	1.00	2.00	1.00	1.50	.91	4.50	6.56	2.13	1.25	2.50	.50	16.88	3.13	.38	5.38	6.13	.44	2.50	1.62	3.25
T20P	2.00	2.25	4.00	3/8	1.38	3.06	1.25	2.50	1.00	2.00	.91	4.25	6.49	2.00	1.25	2.50	.50	17.88	3.75	.38	5.38	6.13	.44	2.50	1.62	3.25
T25	2.50	2.75	4.25	3/8	1.50	3.06	1.00	2.00	1.00	1.50	.91	4.50	6.80	2.13	1.50	3.00	.50	16.88	3.13	.38	5.38	6.13	.44	3.00	1.88	3.75
T25P	2.50	2.75	5.31	3/8	2.13	3.78	1.25	2.50	1.00	2.00	1.03	5.68	8.06	2.66	1.50	3.00	.50	21.38	4.06	.38	6.82	7.57	.44	3.00	1.88	3.75
T32	3.25	3.50	5.31	1/2	1.80	3.72	1.25	2.50	1.00	2.00	1.03	5.50	8.44	2.66	1.86	3.75	.75	21.19	4.06	.50	6.44	7.44	.56	3.75	2.38	4.75
T40	4.00	4.25	6.00	1/2	2.35	3.72	1.25	2.50	1.00	2.00	1.03	6.38	9.50	3.00	2.24	4.50	1.00	23.06	4.63	.50	6.44	7.44	.56	4.50	2.75	5.50
T50	5.00	5.25	6.00	1/2	1.25	4.00	1.50	3.00	1.00	2.88	1.03	6.38	10.25	3.00	2.75	5.50	1.00	23.88	4.75	.68	6.63	8.00	.81	5.50	3.44	6.87

MODEL	AA	BB	CC	DD	EE	FF	GG	HH	JJ	SS	TT
T15	3.50	.75	.19	1.75	3.50	3.50	1.50	3/8-24 X 1.68	3/8-24	1.78	3.00
T20	4.00	1.00	.25	2.25	4.50	5.00	1.50	5/8-18 X 1.68	3/8-24	2.50	4.00
T20P	4.00	1.25	.25	2.88	5.75	6.00	1.50	3/4-16 X 2.25	1/2-13	3.25	5.00
T25	4.50	1.00	.25	2.25	4.50	5.00	1.50	5/8-18 X 1.63	3/8-24	2.50	4.00
T25P	4.50	1.25	.38	2.88	5.75	6.00	1.50	3/4-16 X 2.50	1/2-13	3.25	5.00
T32	5.75	1.25	.31	2.88	5.75	6.00	1.75	3/4-16 X 2.25	1/2-13	3.25	5.00
T40	6.50	1.25	.38	2.88	5.75	6.00	1.75	3/4-16 X 2.50	1/2-13	3.25	5.00
T50	8.25	1.50	.38	5.00	10.00	7.75	1.75	3/4-16 X 2.50	5/8-18	7.00	10.00

NOTE: Dimension TT may be larger than dimension AA. Dimension Z is mounting hole location.

Dimensions in inches
Tolerance on Overall Length is $\pm 1/16"$

MODEL 15, 20, 20P,
25, 25P, 32, 40 & 50

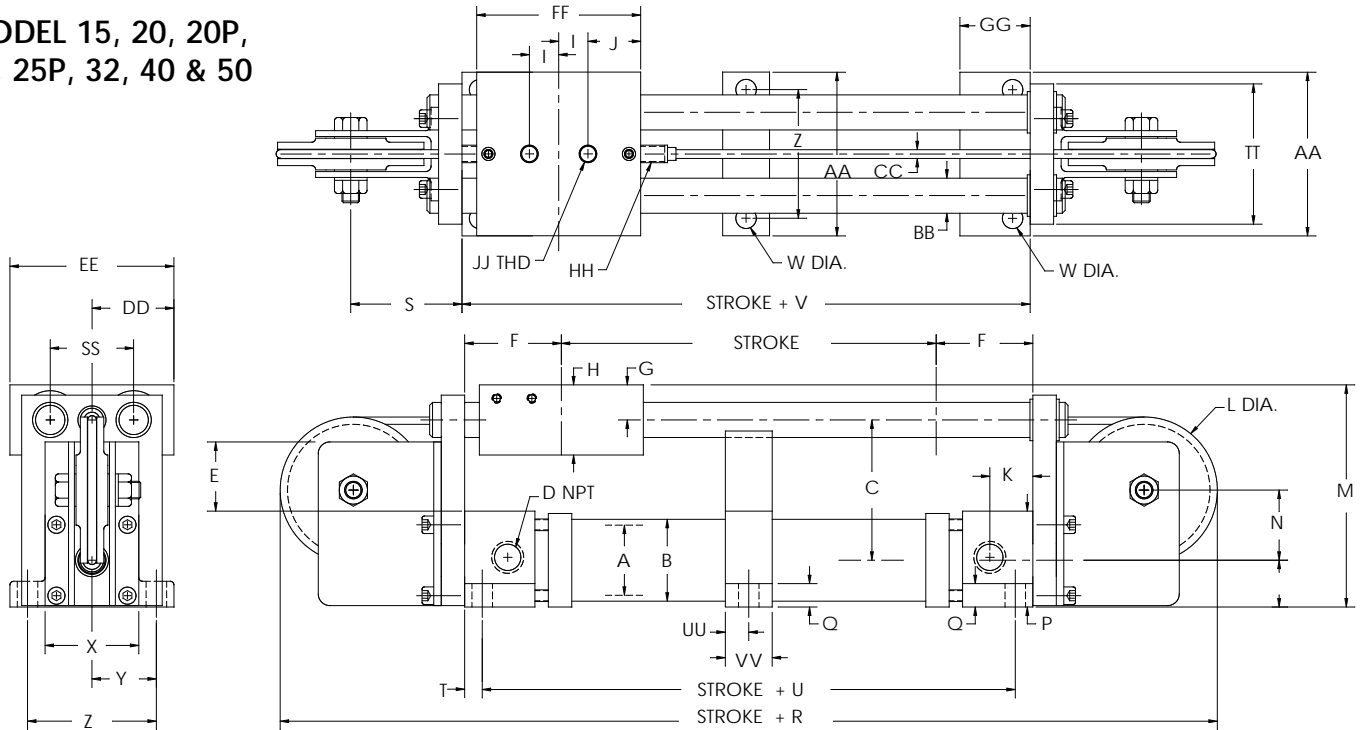

MODEL	A	B	C	D	E	F	G	H	I	J	K	L	M	N	O	P	Q	R	S	T	U	V	W	X	Y	Z
TS15	1.50	1.75	3.00	3/8	1.48	2.06	.75	1.50	.63	1.13	.91	3.13	4.75	1.50	1.00	2.00	.50	12.00	2.38	.38	3.38	4.13	.44	2.00	1.38	2.75
TS20	2.00	2.25	4.25	3/8	1.88	3.09	1.00	2.00	1.00	1.50	.91	4.50	6.53	2.13	1.25	2.50	.50	16.88	3.13	.38	5.38	6.13	.44	2.50	1.62	3.25
TS20P	2.00	2.25	4.00	3/8	1.38	3.06	1.25	2.50	1.00	2.00	.91	4.25	6.49	2.00	1.25	2.50	.50	17.88	3.75	.38	5.38	6.13	.44	2.50	1.62	3.25
TS25	2.50	2.75	4.25	3/8	1.50	3.06	1.00	2.00	1.00	1.50	.91	4.50	6.80	2.13	1.50	3.00	.50	16.88	3.13	.38	5.38	6.13	.44	3.00	1.88	3.75
TS25P	2.50	2.75	5.31	3/8	2.13	3.78	1.25	2.50	1.00	2.00	1.03	5.68	8.06	2.66	1.50	3.00	.50	21.38	4.06	.38	6.82	7.57	.44	3.00	1.88	3.75
TS32	3.25	3.50	5.31	1/2	1.80	3.72	1.25	2.50	1.00	2.00	1.03	5.63	8.44	2.66	1.86	3.75	.75	21.19	4.06	.50	6.44	7.44	.56	3.75	2.38	4.75
TS40	4.00	4.25	6.00	1/2	2.35	3.72	1.25	2.50	1.00	2.00	1.03	6.38	9.50	3.00	2.24	4.50	1.00	23.06	4.63	.50	6.44	7.44	.56	4.50	2.75	5.50
TS50	5.00	5.25	6.00	1/2	1.25	4.00	1.50	3.00	1.00	2.88	1.03	6.38	10.25	3.00	2.75	5.50	1.00	23.88	4.75	.68	6.68	8.00	.81	5.50	3.44	6.87

MODEL	AA	BB	CC	DD	EE	FF	GG	HH	JJ	SS	TT	UU	VV
TS15	3.50	.75	.19	1.75	3.50	3.50	1.50	3/8-24 X 1.68	3/8-24	1.78	3.00	.50	1.00
TS20	4.00	1.00	.25	2.25	4.50	5.00	1.50	5/8-18 X 1.68	3/8-24	2.50	4.00	.63	1.25
TS20P	4.00	1.25	.25	2.88	5.75	6.00	1.50	3/4-16 X 2.25	1/2-13	3.25	5.50	.63	1.25
TS25	4.50	1.00	.25	2.25	4.50	5.00	1.50	5/8-18 X 1.63	3/8-24	2.50	4.00	.63	1.25
TS25P	4.50	1.25	.38	2.88	5.75	6.00	1.50	3/4-16 X 2.25	1/2-13	3.25	5.50	.63	1.25
TS32	5.75	1.25	.31	2.88	5.75	6.00	1.75	3/4-16 X 2.25	1/2-13	3.25	5.00	.75	1.50
TS40	6.50	1.25	.38	2.88	5.75	6.00	1.75	3/4-16 X 2.50	1/2-13	3.25	5.00	.75	1.50
TS50	8.25	1.50	.38	5.00	10.00	7.75	1.75	3/4-16 X 2.50	5/8-18	7.00	10.00	.75	1.50

NOTE: Dimension TT may be larger than dimension AA. Dimension Z is mounting hole location.

FOR MODEL 15 TRAC-TROL® REED SWITCH OPTION INCREASES OVERALL LENGTH BY 2"

Dimensions in inches
Tolerance on overall length $\pm 1/16"$

LOADING — MAXIMUM LOADS —
Horizontal Mounting
MODEL TS15 - 266 lbs. MODEL TS20 & 25 - 450 lbs.
MODEL TS20P, 25P, 32 & 40 - 750 lbs.

IMPORTANT! With inverted mounting, maximum load is one half the horizontal mounting maximum load.

SUPPORT SPACING (All Other Models) — Determine the number of supports for given stroke length by subtracting "KK" from the stroke length, then divide by 24.

$(\text{Stroke} - \text{"KK"}) \div 24 = \text{number of supports}$
(Round to nearest whole number)

From the head mounting holes, the first support is located by the following:
 $\text{Stroke} + U - ((\text{number of supports} - 1) \times 24) = \text{Hole location of first support}$

Other supports are spaced 24" apart.

SUPPORT SPACING (Model TS10 only) — Determine the number of supports for given stroke length by subtracting "KK" from the stroke length, then divide by 12.

$(\text{Stroke} - \text{"KK"}) \div 12 = \text{number of supports}$
(Round to nearest whole number)

From the head mounting holes, the first support is located by the following:
 $\text{Stroke} + U - ((\text{number of supports} - 1) \times 12) = \text{Hole location of first support}$

Other supports are spaced 12" apart.

MODEL	KK	U
TS10	1.94	7.06
TS15	1.94	3.38
TS20	.81	5.38
TS20P	.81	5.38
TS25	.81	5.38
TS25P	.81	6.82
TS32	.69	6.44
TS40	.69	6.44
TS50	.69	6.63

Many applications of the TRAC-TROL® cable cylinder involve mounting some of the weight off the side of the unit. To be certain the correct size TRAC-TROL® is used in your specific application use the $F_s + F_p$ equations to see if the calculated load falls beneath (under) the maximum load limit. Do not exceed the maximum load limit.



AVAILABLE ON TRAC-TROL®
MODELS 10, 15, 20, 20P, 25, 25P, 32, 40 & 50

The internal cushions, standard on all GREENCO cylinders, are an effective method to decelerate loads, and minimize harmful shock loading at the end of each stroke.

In very high speed applications, cushions may be overloaded and shock absorbers are necessary.

The GREENCO External Shock Absorber Package is a highly effective way to minimize shock loading in a wide variety of applications (refer to chart). Additionally, the package utilizes (2) two fully adjustable, mechanical stops to vary stroke length as may be required by the application.

SHOCK PACKAGE CONSISTS OF: 2-shock absorbers, 2-shock mounting blocks, 2-stop collars, 2-locknuts and 2-adjustable stops.

IMPORTANT - some applications may exceed shock design limits and could require a special orifice or non-standard shock absorber. Consult Factory.

EXAMPLE - application requiring a TRAC-TROL® model 15 with 100 PSI, and a payload weight of 80 lbs. Referring to the sizing chart you would find 80 lbs. on the vertical axis and move across until you intersect with model 15 line curve, from this intersection move toward the horizontal axis of the chart which tells you the maximum velocity allowed at impact (5.3 fps).

Shock operating temperature 32° -150° F. At maximum loads cycle rates must be limited to 30 hits per minute on model 10 and 17 hits per minute on models 15, 20, 25, 32, 40 and 50. Cycle rates increase with lower loads.

NOTE - Shock Package Adds to Cylinder O.A.L.

MODEL	INCREASE IN O.A.L.
T10	5.00"
T15, TS15	5.375"
T20, T25, TS20, TS25	5.125"
T20P, T25P, T32, T40, TS40, TS20P, TS25P, TS32	6.06"
T50	6.75"

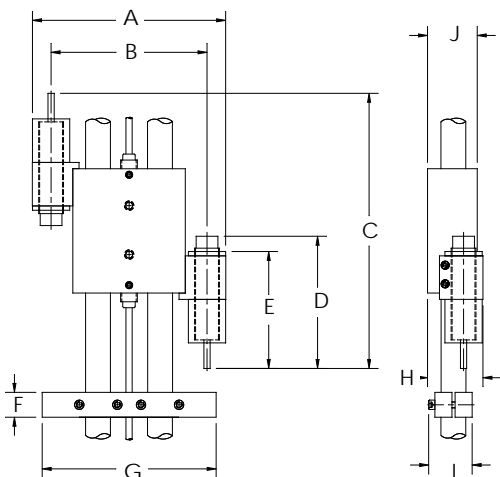
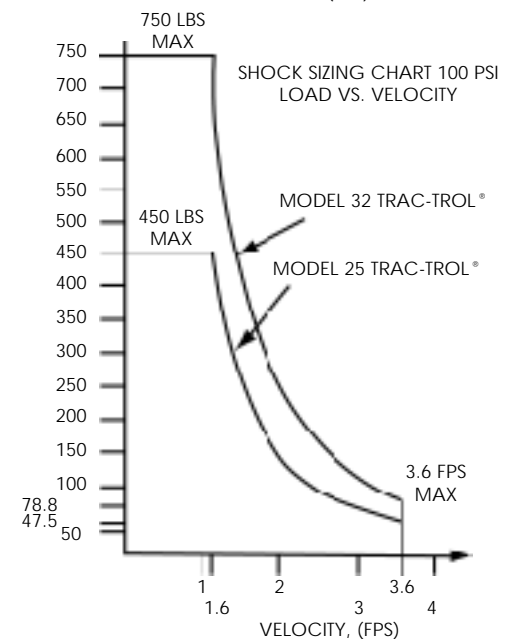
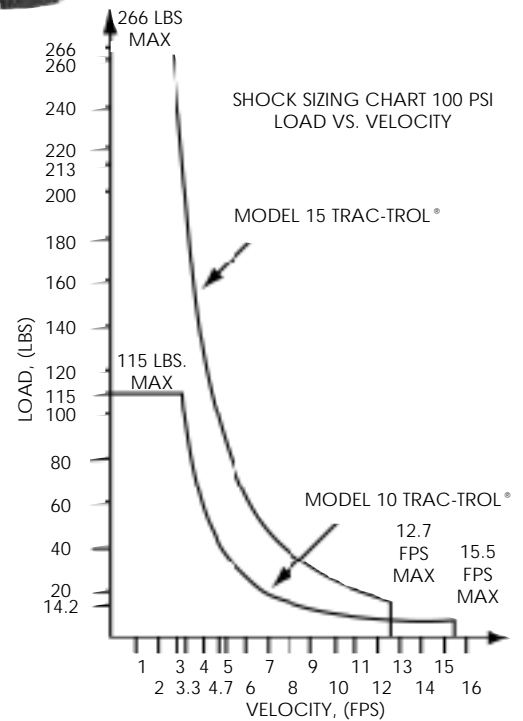

Dimensions in inches

DIMENSION TABLE FOR SHOCKS, 10, 15, 20, 20P, 25, 25P, 32, 40, 50

	A	B	C	D	E	F	G	H	I	J
T10	4.75	3.63	7.31	3.81	3.50	1.00	4.38	1.53	1.16	1.13
T15, TS15	6.75	5.25	9.50	5.09	4.50	1.00	6.00	1.81	1.31	1.50
T20, T25, TS20, TS25	7.75	6.25	11.00	5.09	4.50	1.00	7.00	1.23	1.81	2.00
T20P, T25P, T32, TS20P, TS25P, TS32, TS40	9.00	7.50	12.00	5.09	4.50	1.00	8.25	2.50	2.31	2.50
T50, TS50	13.25	11.75	13.75	5.09	4.50	1.00	12.25	3.00	2.38	3.00

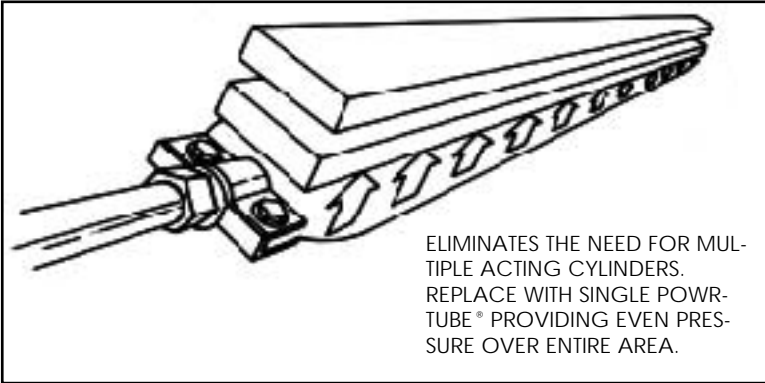

POWR-TUBE® provides a unique construction of a non-removable end fitting bonded to a tube (up to almost 100 ft. length) to give a leak proof, long-lasting, low-cost, short-stroke linear actuator. Pneumatic or hydraulic service.

- Light Weight
- Simple Construction, Easy to Mount
- Low Cost
- **NO** Maintenance

TEMP. RATING: 180°
MAXIMUM OPERATING PRESSURE 100 PSI

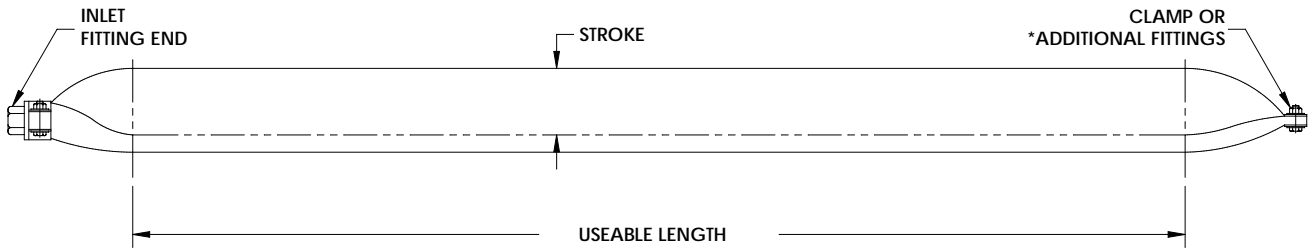

FUNCTIONS & APPLICATIONS - Lifting, Clamping, Positioning, Hold, Release and Cushioning

* DUAL FITTINGS RECOMMENDED FOR MAXIMUM AIR FLOW

TYPICAL MOUNTINGS (NOT PROVIDED)

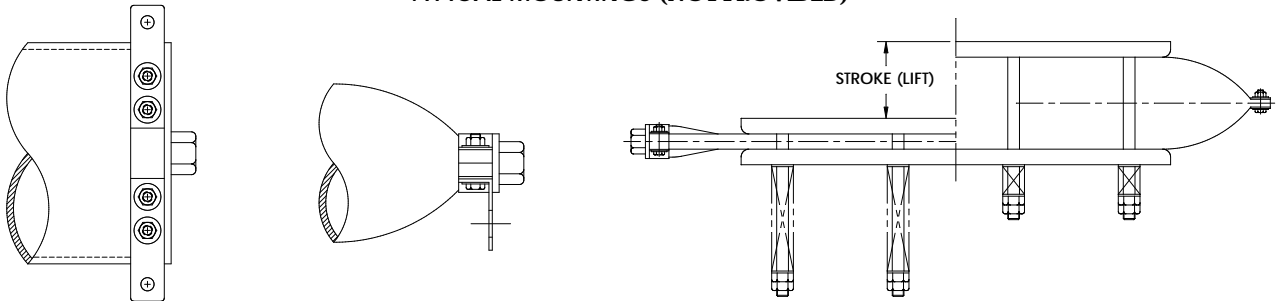

HOW TO ORDER

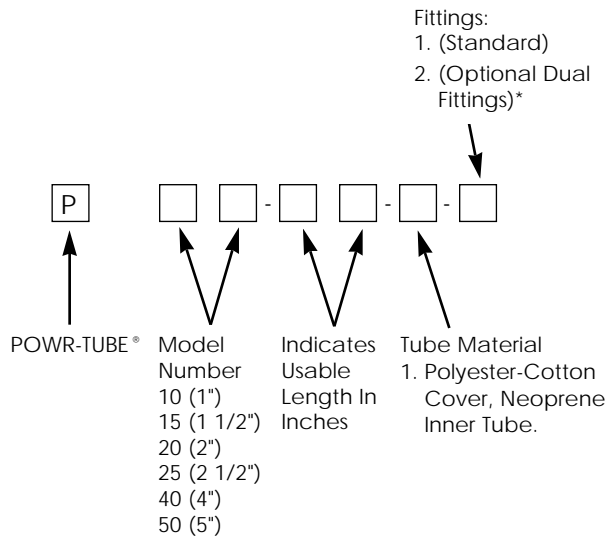

OUTPUT FORCE CALCULATION

OUTPUT FORCE TABLE IS COMPUTED FROM THE FOLLOWING FORMULA:

$$1.57 \times (\text{BORE} - \text{LIFT}) \times \frac{\text{EFFECTIVE LENGTH}}{\text{LIFT}} \times \text{INPUT AIR PRESSURE} = \text{OUTPUT FORCE}$$

F [LB] = 1.57 (D - l) LP
 where d = TUBE DIA. (INCHES) (BORE SIZE)
 l = LIFT (INCHES)
 L = USEABLE LENGTH (INCHES)
 P = INPUT PRESSURE (P.S.I.)

TYPICAL OUTPUT FORCES PER 10 INCHES OF EFFECTIVE LENGTH AT 100 PSI PRESSURE AT LIFT OF:

POWR-TUBE® MODEL	LIFT									
	.2"	.5"	1"	1.5"	2"	2.5"	3"	3.5"	4"	4.5"
P10-10 (1.0" Dia.)	1255	785								
P15-10 (1.5" Dia.)	2040	1570	785							
P20-10 (2.0" Dia.)	2825	2355	1570	785						
P25-10 (2.5" Dia.)	3610	3140	2355	1570	785					
P40-10 (4.0" Dia.)	5970	5500	4710	3925	3140	2355	1570	785		
P50-10 (5.0" Dia.)	7540	7070	6280	5500	4710	3925	3140	2355	1570	785

EXAMPLE:

2" POWR-TUBE® with 1" total lift, 10" effective length at 100 psi
 Model Number

P2010-1-1 1.57 X (2.0 - 1.0) x 10 x 100 = 1570 lbs.

* DUAL FITTINGS RECOMMENDED FOR MAXIMUM AIR FLOW

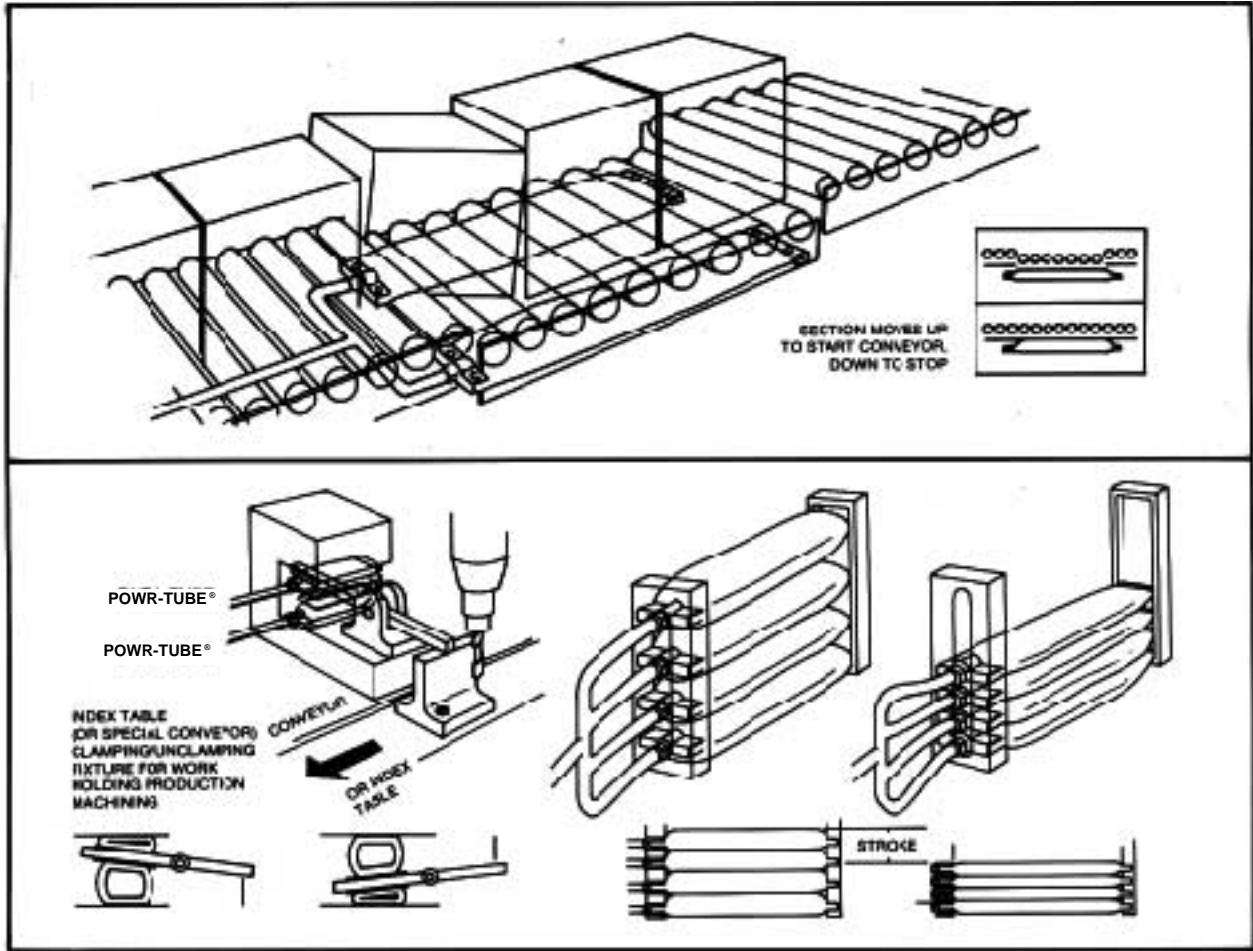

MODEL	A	B	C	D	F	G	J	K
P10	1.67	-	1.06	.64	.88	#8-32 X .75	4 1/2	.10
P15	2.30	-	1.50	.75	1.25	1/4-20 X 1.00	6 1/8	.11
P20	3.20	-	2.25	.72	1.25	3/8-16 X 1.25	7 5/16	.11
P25	3.86	-	2.50	.72	1.25	3/8-16 X 1.25	8	.12
P40	6.75	5.00	2.50	1.00	1.25	3/8-24 X 1.75	12	.16
P50	8.25	6.75	4.25	1.00	1.25	3/8-24 X 1.75	15	.25

MODEL	L	N	P	Q	R	S	T	U	V
P10	2 5/8	.88	1.25	-	2.00	.89	.75	.52	1 1/4
P15	4	1.25	1.75	-	2.75	1.14	.88	.64	1 7/8
P20	5 1/8	1.25	2.25	-	3.63	1.40	1.12	.66	2 1/8
P25	5 7/8	1.25	3.00	-	4.38	1.67	1.12	.71	2 5/8
P40	9 1/2	1.25	2.50	5.00	6.50	2.13	1.38	2.13	4 1/2
P50	12 1/2	1.25	3.50	7.00	8.63	2.13	1.38	2.13	6

MODEL	X	Y	Z	DD	FF	PORT (NPT)	ORIFICE
P10	1.25	1 3/8	#8-32 X .38	.33	.78	1/4-18 FEMALE	.24
P15	1.75	2 1/8	1/4-20 X .75	.39	1.14	3/8-18 FEMALE	.37
P20	2.33	3	3/8-16 X 1.00	.40	1.32	1/2-14 FEMALE	.47
P25	2.88	3 1/4	3/8-16 X 1.00	.41	1.33	1/2-14 FEMALE	.47
P40	4.48	5	3/8-24 X 1.00	.49	1.41	3/4-14 MALE	.65
P50	5.90	6 1/2	3/8-24 X 1.25	.68	1.60	3/4-14 MALE	.65

Tolerances: $\pm 1/4"$ on Fractions
 $\pm .03$ on 2-Place Decimals
 Dimensions in inches

POWR-TUBE® SUBJECT TO APPROXIMATELY 5% STRETCH IN OVERALL LENGTH.

ENGINEERING SPECIFICATIONS

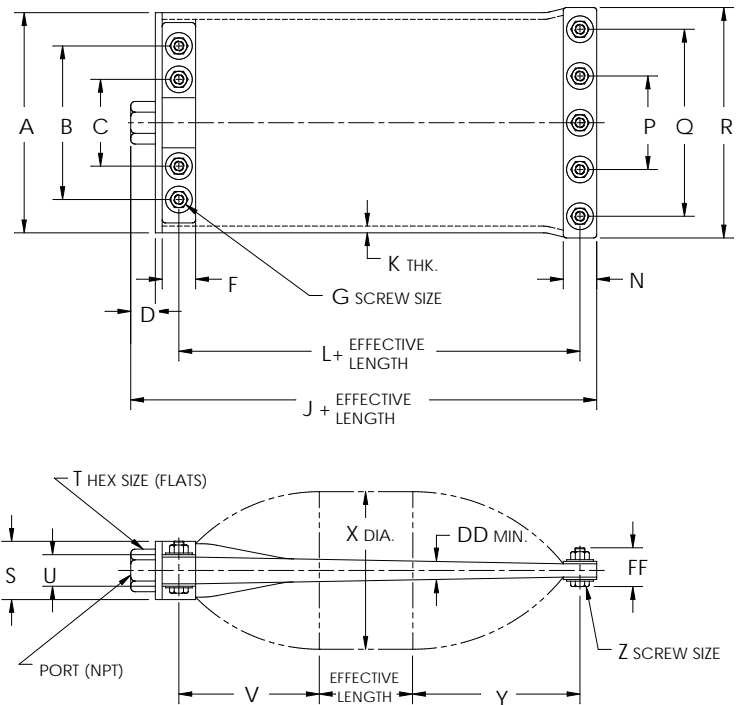

METERING-OUT CIRCUIT

This circuit is typical for many cable cylinder speed control applications. The cylinder stroke in this schematic is common for **GREENCO** units.

Energizing solenoid "A" flows air through the 4-way valve and a ball check to piston. As the piston moves to the right the trolley attached to the load moves to left. Air inside the cylinder is forced out through a metering valve. This circuit maintains a constant back pressure on the piston and prevents lunging if the load drops quickly or reverses. Metering-in and bleed-off circuits work well when their application is required.

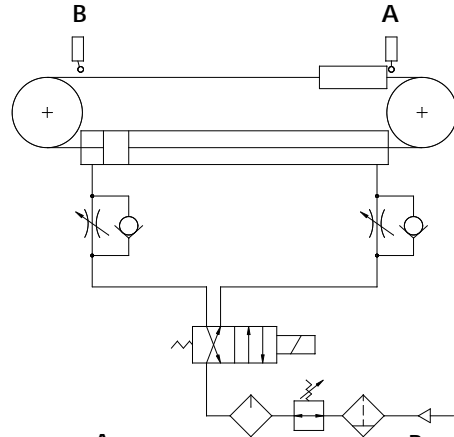

HYDRAULIC CIRCUIT

This circuit incorporates a high pressure hydraulic cable cylinder. Oil is supplied from a hydraulic power supply at 500 PSI maximum to a 4-way valve.

Energizing solenoid "B" flows oil through a ball check to the cylinder's piston. Oil inside the cylinder is regulated out for effective speed control. Energizing solenoid "A" reverses the cycle. All seals within the cylinder function more effectively with hydraulic fluid added lubrication at these pressures.

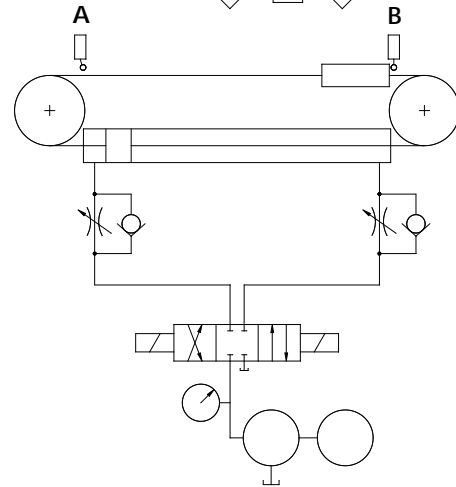

COMBINATION AIR-OIL CIRCUIT

This circuit combines the rapid operation of pneumatic circuits and close control available in hydraulic circuits to form effective machine circuits. This system is economical because an adequate air supply is usually available.

Energizing solenoid "A" air flows through the 4-way applying pressure on the oil in the tank No. 1. Oil flows through the check valve to the piston moving it to the right. Oil inside the cable cylinder is regulated out by a variable flow control valve. This circuit gives fine speed control.

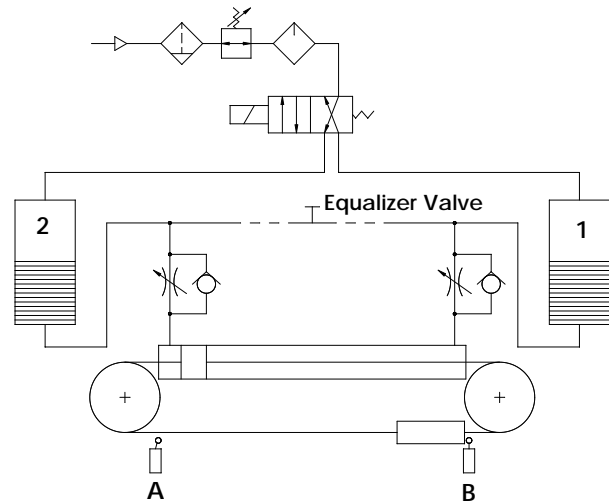

SINGLE ACTING AIR-OIL CIRCUIT

This circuit incorporates a single-end **CABLE-TROL®** unit when gravity is used to lower a load. The load may be a heavy door or something similar. Hydraulic speed control is needed; however, rather than employing a hydraulic unit to power the system, a more economical air system is used. To raise the load, the 3-way valve is activated, opening the reservoir to air pressure. Oil is forced from the reservoir, through the check valve and into the cable cylinder, forcing the piston to the left and raising the load. Reversing the 3-way valve, air pressure is blocked and gravity lowers the load at a rate of speed governed by variable orifice.

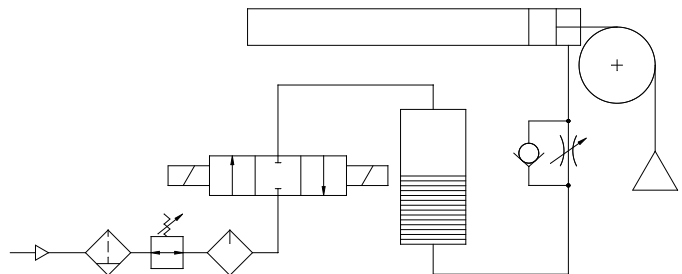

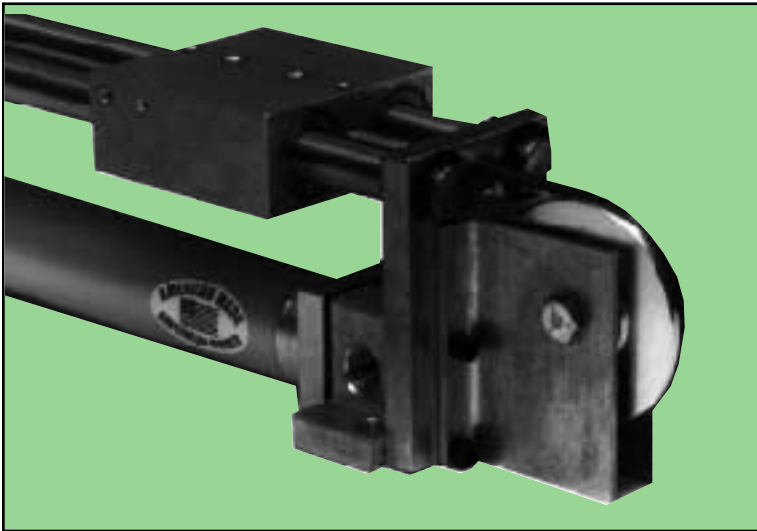

ISO 9001:2000 CERTIFICATION
No. 5047 1494



RODLESS CYLINDER COMPARISON

CABLE-TYPE



TRAC-TROL® guides on close-tolerance metal bearings, completely separated from piston and cable seals. When loaded, there is still no effect on sealing mechanism.

TRAC-TROL® has superior sealing mechanism which allows hydraulic service for very smooth, long-life performance.

TRAC-TROL® seals through two nylon covered aircraft type, steel cables held to ± 0.004 on the O.D., many times stronger than load carried.

TRAC-TROL® has low-cost cable and rod wipers available for extremely contaminated areas.

TRAC-TROL® offers 7 bore sizes.

BAND-TYPE



Load transmitted directly to piston and could affect sealing detrimentally.

Hydraulic service not possible. Must seal entire length of extrusion.

Must seal entire length of tube, exposing much more surface to air loss and contamination problems.

Not available. Real problems in contamination areas.

Limited range of bore sizes.



Stop by and visit our headquarters



in sunny Florida!



AIR/OIL TANK (page 11)



POWR-TUBE (pages 22-23)

DISTRIBUTED BY

GREENCO

LEADERS IN RODLESS CYLINDERS

GREENCO CORPORATION

5688 w. Crenshaw

Tampa, FL 33634

(813) 882-4400 • FAX (813) 888-6688

www.greencocylinders.com

e mail: sales@greencocylinders.com