



# **PATRIOT**

## **PHDA10V SERIES**

### **FULL CATALOG**



**Driven by Innovation**  
**Power Precision Performance**  
734-479-9641 [patriothyd.com](http://patriothyd.com)





## PHDA10V Description

---

The PHDA10V replacement pump series features a variable displacement axial piston design with a swashplate configuration, ideal for open-circuit hydrostatic drives. Flow output is proportional to drive speed and can be infinitely adjusted via the swashplate angle for precise control. The design incorporates a hydrostatically unloaded cradle bearing, contributing to low noise operation, excellent suction performance, and long service life. Additional benefits include a strong power-to-weight ratio, fast response times, and a versatile range of control options. The unit also includes dual leakage ports and offers through-drive capability, allowing multiple pumps of the same nominal size to be mounted in tandem for increased system flexibility.

## Type code

01	02	03	04	05	06	07	08	09	10	11	12
PHDA10V*O			/	31	-	V					

Version		18	28	45	71	88	100	140	
01	Standard version (without code)	•	•	•	•	•	•	•	
	High-speed version (external dimensions are the same as the standard version)	-	-	•	•	-	•	•	H

### Axial piston unit

01	Swashplate design, variable, nominal pressure 280 bar, maximum pressure 350 bar	•	-	-	-	-	-	-	A10VS
		-	•	•	•	•	•	•	A10V

### Operating mode

02	Pump, open circuit	O
----	--------------------	---

### Size (NG)

03	Geometric displacement, see table of values on pages 5 and 6	18	28	45	71	88	100	140
----	--	----	----	----	----	----	-----	-----

### Control device

04	Two-point control, direct operated		•	•	•	•	•	•	•	DG			
	Pressure controller	hydraulic	•	•	•	•	•	•	•	•	DR		
		with flow controller	hydraulic	X-T open X-T plugged with flushing function X-T plugged without flushing function	•	•	•	•	•	•	•	DFR	
			•		•	•	•	•	•	•	DFR1		
			•		•	•	•	•	•	•	DRSC		
		with flow and differential pressure control, electrically variable		•	•	•	•	•	•	•	EF <sup>1)</sup>		
	with pressure cut-off	hydraulic	remote controlled	•	•	•	•	•	•	•	•	DRG	
			electrical	negative control	$U = 12\text{ V}$	•	•	•	•	•	•	•	ED71
				$U = 24\text{ V}$	•	•	•	•	•	•	•	•	ED72
		electrical	positive control	$U = 12\text{ V}$	•	•	•	•	•	•	•	•	ER71
$U = 24\text{ V}$	•			•	•	•	•	•	•	•	•	ER72	
	Pressure-flow power control		-	•	•	•	•	•	•	•	DFLR		

### Series

05	Series 3, index 1	31
----	-------------------	----

### Direction of rotation

06	Viewed on drive shaft	clockwise	R
		counter-clockwise	L

### Sealing material

07	FKM (fluoroelastomer)	V
----	-----------------------	---

### Drive shaft

		18	28	45	71	88	100	140		
08	Splined shaft ANSI B92.1a	standard shaft	•	•	•	•	•	•	•	S
		similar to shaft "S" however for higher input torque	•	•	•	•	•	-	-	R
		reduced diameter, limited suitability for through drive (see table of values, page 5)	•	•	•	•	•	•	○	U
		same as "U", higher torque; limited suitability for through drive (see table of values, page 5)	-	•	•	•	•	•	•	•

### Mounting flange

09	ISO 3019-1 (SAE)	2-hole	•	•	•	•	•	•	•	C
		4-hole	-	-	-	-	-	-	•	D

01	02	03	04	05	06	07	08	09	10	11	12
PHDA10V*O			/	31		-	V				

**Working port**

				18	28	45	71	88	100	140	
10	SAE flange ports according to J518	Fastening thread <b>metric</b> ; rear	not for through drive	-	●	●	-	-	●	●	11
				-	-	-	●	●	-	-	41
	Working ports <b>metric</b>	Fastening thread <b>metric</b> ; lateral top bottom	for through drive	●	●	●	-	-	●	●	12
				-	-	-	●	●	-	-	42
	SAE flange ports according to J518	Fastening thread <b>UNF</b> ; rear	not for through drive	-	●	●	-	-	●	●	61
				-	-	-	●	●	-	-	91
	Working ports <b>UNF</b>	Fastening thread <b>UNF</b> ; lateral top bottom	for through drive	●	●	●	-	-	●	●	62
				-	-	-	●	●	-	-	92

**Through drive** (for mounting options, see page 53)

				18	28	45	71	88	100	140	
11	Flange ISO 3019-1	Hub for splined shaft <sup>2)</sup>									
	Diameter	Diameter									
	without through drive			●	●	●	●	●	●	●	N00
82-2 (A)	5/8 in	9T 16/32DP		●	●	●	●	●	●	●	K01
		3/4 in	11T 16/32DP	●	●	●	●	●	●	●	K52
101-2 (B)	7/8 in	13T 16/32DP		-	●	●	●	●	●	●	K68
		1 in	15T 16/32DP	-	-	●	●	●	●	●	K04
127-2 (C)	1 1/4 in	14T 12/24DP		-	-	-	●	●	●	●	K07
		1 1/2 in	17T 12/24DP	-	-	-	-	-	●	●	K24
152-4 (D)	1 3/4 in	13T 8/16DP		-	-	-	-	-	-	●	K17

**Connectors for solenoids<sup>3)</sup>**

				18	28	45	71	88	100	140	
12	Without connector (without solenoid, with hydraulic control only, without code)			●	●	●	●	●	●	●	
	DEUTSCH - molded connector, 2-pin, without suppressor diode			●	●	●	●	●	●	●	P

● = Available    ○ = On request    - = Not available

**Notice**

- ▶ Note the project planning notes on page 59.
- ▶ In addition to the type code, please specify the relevant technical data when placing your order.

## Technical data, standard unit

Size	NG	18	28	45	71	88	100	140	
Displacement, geometric, per revolution	$V_{g \max}$ cm <sup>3</sup>	18	28	45	71	88	100	140	
Rotational speed maximum <sup>1)</sup>	at $V_{g \max}$	$n_{\text{nom}}$ rpm	3300	3000	2600	2200	2100	2000	1800
	at $V_g < V_{g \max}$ <sup>2)</sup>	$n_{\text{max perm}}$ rpm	3900	3600	3100	2600	2500	2400	2100
Flow	at $n_{\text{nom}}$ and $V_{g \max}$	$q_{v \max}$ gpm	15.59	22.19	30.91	41.21	48.87	52.83	66.57
	at $n_E = 1500$ rpm and $V_{g \max}$	$q_{vE \max}$ gpm	7.13	11.10	17.96	28.27	34.87	39.63	55.48
Power at $\Delta p = 280$ bar	at $n_{\text{nom}}$ , $V_{g \max}$	$P_{\max}$ kW	28	39	55	73	86	93	118
	at $n_E = 1500$ rpm and $V_{g \max}$	$P_{E \max}$ kW	12.6	20	32	50	62	70	98
Torque at $V_{g \max}$ and	$\Delta p = 280$ bar	$T_{\max}$ Nm	80	125	200	316	392	445	623
	$\Delta p = 100$ bar	$T$ Nm	30	45	72	113	140	159	223
Rotary stiffness of drive shaft	S	$c$ Nm/rad	11087	22317	37500	71884	71884	121142	169437
	R	$c$ Nm/rad	14850	26360	41025	76545	76545	–	–
	U	$c$ Nm/rad	8090	16695	30077	52779	52779	91093	–
	W	$c$ Nm/rad	–	19898	34463	57460	57460	101847	165594
Moment of inertia for rotary group	$J_{TW}$ kgm <sup>2</sup>	0.00093	0.0017	0.0033	0.0083	0.0083	0.0167	0.0242	
Maximum angular acceleration <sup>3)</sup>	$\alpha$ rad/s <sup>2</sup>	6800	5500	4000	2900	2600	2400	2000	
Case volume	$V$ l	0.4	0.7	1.0	1.6	1.6	2.2	3.0	
Weight <b>without</b> through drive (approx.)	$m$ kg	12.9	18	23.5	35.2	35.2	49.5	65.4	
Weight <b>with</b> through drive (approx.)		13.8	19.3	25.1	38	38	55.4	74.4	

### Determining the operating characteristics

Flow	$q_v = \frac{V_g \times n \times \eta_v}{1000}$	[l/min]
Torque	$T = \frac{V_g \times \Delta p}{20 \times \pi \times \eta_{hm}}$	[Nm]
Power	$P = \frac{2 \pi \times T \times n}{60000} = \frac{q_v \times \Delta p}{600 \times \eta_t}$	[kW]

### Key

$V_g$  Displacement per revolution [cm<sup>3</sup>]

$\Delta p$  Differential pressure [bar]

$n$  Rotational speed [rpm]

$\eta_v$  Volumetric efficiency

$\eta_{hm}$  Hydraulic-mechanical efficiency

$\eta_t$  Total efficiency ( $\eta_t = \eta_v \times \eta_{hm}$ )

1) The values are applicable:

- At absolute pressure  $p_{\text{abs}} = 1$  bar at suction port **S**
- For the optimal viscosity range of  $\nu_{\text{opt}} = 36$  to  $16$  mm<sup>2</sup>/s
- For hydraulic fluid based on mineral oils

2) For a speed increase up to  $n_{\text{max perm}}$ , please observe the diagram on page 6.

### Notice

- ▶ Theoretical values, without efficiency and tolerances; values rounded
- ▶ Operation above the maximum values or below the minimum values may result in a loss of function, a reduced service life or in the destruction of the axial piston unit.

3) The data are valid for values between the minimum required and maximum permissible rotational speed. It applies for external stimuli (e. g. diesel engine 2 to 8 times rotary frequency, Cardan shaft twice the rotary frequency). The limit value is only valid for a single pump. The load capacity of the connecting parts must be considered.

## Technical data, high-speed version

Size		NG		45	71	100	140
Displacement, geometric, per revolution		$V_{g \max}$	cm <sup>3</sup>	45	71	100	140
Rotational speed maximum <sup>1)</sup>	at $V_{g \max}$	$n_{\text{nom}}$	rpm	3000	2550	2300	2050
	at $V_g < V_{g \max}$ <sup>2)</sup>	$n_{\text{max perm}}$	rpm	3300	2800	2500	2200
Flow	at $n_{\text{nom}}$ and $V_{g \max}$	$q_{v \max}$	gpm	35.66	47.03	60.76	75.81
Power	at $n_{\text{nom}}$ , $V_{g \max}$ and $\Delta p = 280$ bar	$P_{\text{max}}$	kW	63	83	107	134
Torque	$\Delta p = 280$ bar	$T_{\text{max}}$	Nm	200	316	445	623
	at $V_{g \max}$ and $\Delta p = 100$ bar	$T$	Nm	72	113	159	223
Rotary stiffness of drive shaft	S	$c$	Nm/rad	37500	71884	121142	169537
	R	$c$	Nm/rad	41025	76545	–	–
	U	$c$	Nm/rad	30077	52779	91093	–
	W	$c$	Nm/rad	34463	57460	101847	165594
Moment of inertia for rotary group		$J_{\text{TW}}$	kgm <sup>2</sup>	0.0033	0.0083	0.0167	0.0242
Maximum angular acceleration <sup>3)</sup>		$\alpha$	rad/s <sup>2</sup>	4000	2900	2400	2000
Case volume		$V$	l	1.0	1.6	2.2	3.0
Weight <b>without</b> through drive (approx.)			kg	23.5	35.2	49.5	65.4
Weight <b>with</b> through drive (approx.)		$m$	kg	25.1	38	55.4	74.4

### Notice

- ▶ Theoretical values, without efficiency and tolerances; values rounded
- ▶ Operation above the maximum values or below the minimum values may result in a loss of function, a reduced service life or in the destruction of the axial piston unit.

1) The values are applicable:

- At absolute pressure  $p_{\text{abs}} = 1$  bar at suction port **S**
- For the optimal viscosity range of  $\nu_{\text{opt}} = 36$  to  $16$  mm<sup>2</sup>/s
- For hydraulic fluid based on mineral oils

2) For a speed increase up to  $n_{\text{max perm}}$ , please observe the diagram on page 6.

3) The data are valid for values between the minimum required and maximum permissible rotational speed. It applies for external stimuli (e. g. diesel engine 2 to 8 times rotary frequency, Cardan shaft twice the rotary frequency). The limit value is only valid for a single pump. The load capacity of the connecting parts must be considered.

## Viscosity and temperature of hydraulic fluids

	Viscosity	Temperature	Comment
Cold start	$\nu_{\max} \leq 1600 \text{ mm}^2/\text{s}$	$\theta_{\text{St}} \geq -40 \text{ }^\circ\text{C}$	$t \leq 1 \text{ min}$ , without load ( $p \leq 30 \text{ bar}$ ), $n \leq 1000 \text{ rpm}$
	Permissible temperature difference	$\Delta T \leq 25 \text{ K}$	between axial piston unit and hydraulic fluid
Warm-up phase	$\nu < 1600 \text{ to } 400 \text{ mm}^2/\text{s}$	$\theta = -40 \text{ }^\circ\text{C to } -25 \text{ }^\circ\text{C}$	Note the detailed information on operation with low temperatures, see data sheet 90300-03-B
Continuous operation	$\nu = 400 \text{ to } 10 \text{ mm}^2/\text{s}$	$\theta = -25 \text{ }^\circ\text{C to } +110 \text{ }^\circ\text{C}$	this corresponds, for VG 46 for example, to a temperature range of $+5 \text{ }^\circ\text{C to } +85 \text{ }^\circ\text{C}$ (see selection diagram)
	$\nu_{\text{opt}} = 36 \text{ to } 16 \text{ mm}^2/\text{s}$		measured at port <b>L, L<sub>1</sub></b> observe the permissible temperature range of the shaft seal ( $\Delta T = \text{approx. } 5 \text{ K}$ between the bearing/shaft seal and port <b>L, L<sub>1</sub></b> ) Range of optimum operating viscosity and efficiency
Short-term operation	$\nu_{\min} \geq 7 \text{ mm}^2/\text{s}$		$t < 1 \text{ min}$ , $p < 0.3 \cdot p_{\text{nom}}$

### ▼ Selection diagram

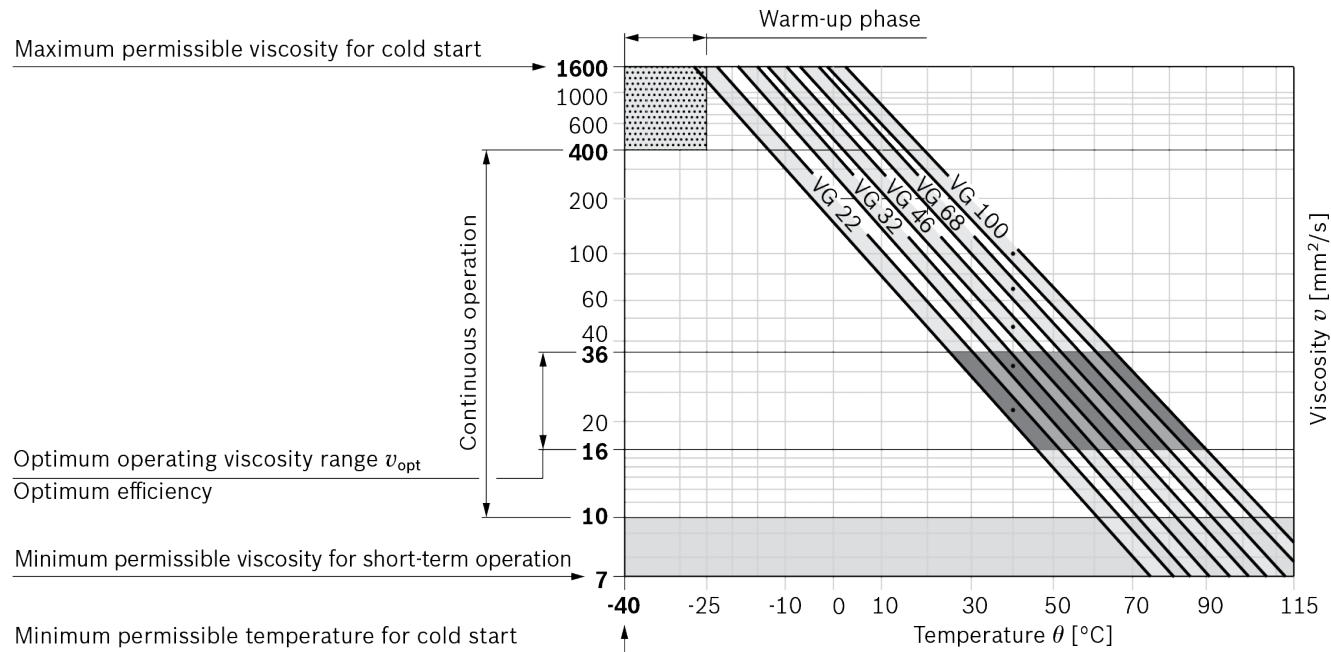

## Permissible radial and axial forces of the drive shafts

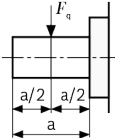
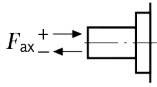
Size		NG	18	28	45	71	88	100	140	
Maximum radial force at a/2		$F_{q \max}$	N	350	1200	1500	1900	1900	2300	2800
Maximum axial force		$\pm F_{ax \max}$	N	700	1000	1500	2400	2400	4000	4800

### Notice

- The values given are maximum values and do not apply to continuous operation.
- For drives with radial loading (pinion, V-belt drives), please contact us!

## Permissible input and through-drive torques

Size			18	28	45	71	88	100	140
Torque at $V_{g \max}$ and $\Delta p = 280 \text{ bar}^1$ )	$T_{max}$	Nm	80	125	200	316	392	445	623
Maximum input torque at drive shaft <sup>2)</sup>									
S	$T_{E \max}$	Nm	124	198	319	626	626	1104	1620
	$\emptyset$	in	3/4	7/8	1	1 1/4	1 1/4	1 1/2	1 3/4
R	$T_{E \max}$	Nm	160	250	400	644	644	–	–
	$\emptyset$	in	3/4	7/8	1	1 1/4	1 1/4	–	–
U	$T_{E \max}$	Nm	59	105	188	300	300	595	–
	$\emptyset$	in	5/8	3/4	7/8	1	1	1 1/4	–
W	$T_{E \max}$	Nm	–	140	220	394	394	636	1220
	$\emptyset$	in	–	3/4	7/8	1	1	1 1/4	1 1/2
Maximum through-drive torque									
S	$T_{D \max}$	Nm	108	160	319	492	492	778	1266
R	$T_{D \max}$	Nm	120	176	365	548	548	–	–
U	$T_{D \max}$	Nm	59	105	188	300	300	595	–
W	$T_{D \max}$	Nm	–	140	220	394	394	636	1220

### ▼ Distribution of torques

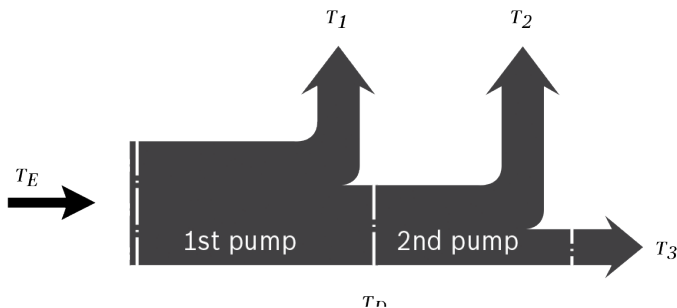

Torque at 1st pump	$T_1$
Torque at 2nd pump	$T_2$
Torque at 3rd pump	$T_3$
Input torque	$T_E = T_1 + T_2 + T_3$
	$T_E < T_{E \max}$
Through-drive torque	$T_D = T_2 + T_3$
	$T_D < T_{D \max}$

1) Efficiency not considered

2) For drive shafts with no radial force

## DG – Two-point control, direct operated

The variable pump can be set to a minimum swivel angle by connecting an external control pressure to port **X**.

This will supply control fluid directly to the stroking piston; a minimum control pressure of  $p_{st} \geq 50$  bar is required.

The variable pump can only be switched between  $V_{g\ max}$  or  $V_{g\ min}$ .

Please note that the required control pressure at port **X** is directly dependent on the actual working pressure  $p_B$  in port **B**. (See control pressure characteristic).

The maximum permissible control pressure is 280 bar.

Control pressure  $p_{st}$  in **X** = 0 bar  $\triangleq V_{g\ max}$

Control pressure  $p_{st}$  in **X**  $\geq 50$  bar  $\triangleq V_{g\ min}$

### ▼ Control pressure characteristic curve

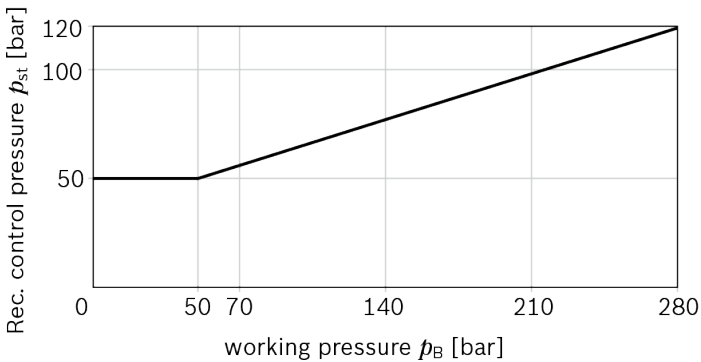

### ▼ Circuit diagram

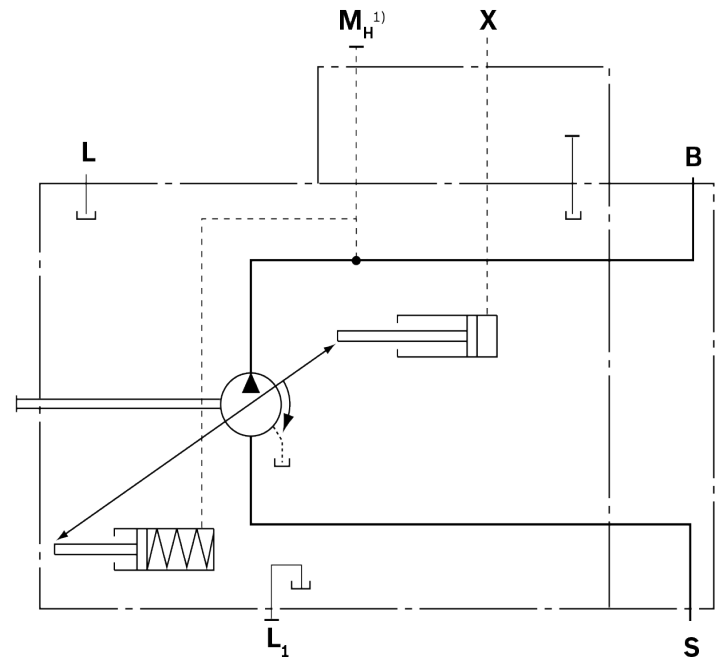

## DR – Pressure controller

The pressure controller limits the maximum pressure at the pump outlet within the control range of the variable pump. The variable pump only supplies as much hydraulic fluid as is required by the consumers. If the working pressure exceeds the pressure command value at the pressure valve, the pump will regulate to a smaller displacement to reduce the control differential.

- ▶ Initial position in depressurized state:  $V_{g \max}$ .
- ▶ Setting range<sup>1)</sup> for pressure control 20 to 280 bar. Standard is 280 bar.

### ▼ Characteristic curve

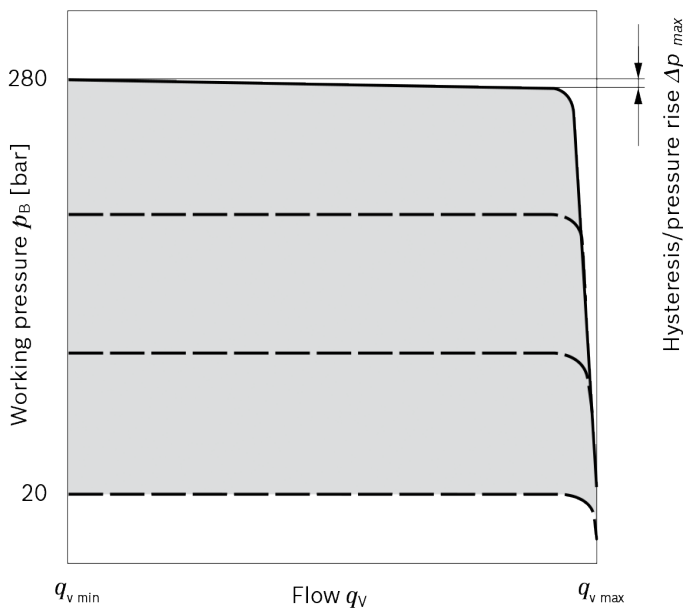

Characteristic curve valid at  $n_1 = 1500$  rpm and  $\theta_{\text{fluid}} = 50$  °C.

1) In order to prevent damage to the pump and the system, the permissible setting range must not be exceeded. The range of possible settings at the valve is higher.

### ▼ Circuit diagram, sizes 18 to 100

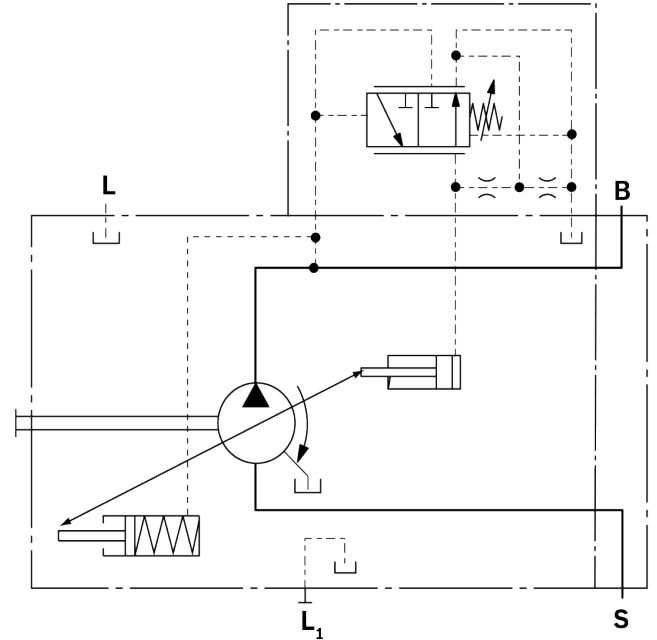

### ▼ Circuit diagram, size 140

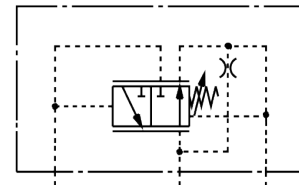

### Controller data

NG		18	28	45	71	88	100	140
Pressure increase	$\Delta p$ [bar]	4	4	6	8	9	10	12
Hysteresis and repeatability	$\Delta p$ [bar]	maximum 3						
Control fluid consumption	[l/min]	maximum approx. 3						

## DRG – Pressure controller, remote controlled

For the remote controlled pressure controller, the LS pressure limitation is performed using a separately arranged pressure relief valve. Therefore any pressure control value under the pressure set on the pressure controller can be regulated. Pressure controller DR see page 11.

A pressure relief valve is externally piped up to port **X** for remote control. This relief valve is not included in the scope of delivery of the DRG control.

When there is differential pressure  $\Delta p$  at the control valve and with the standard setting on the remote controlled pressure cut-off of 20 bar, the amount of control fluid at the port is **X** approx. 1.5 l/min. If a different setting (range 10 to 22 bar) is required, please state in plain text.

As a separate pressure relief valve (**1**) we recommend:

- ▶ a direct operated hydraulic or electric proportional one, suitable for the control fluid mentioned above.

The max. length of piping should not exceed 2 m.

- ▶ Basic position in depressurized state:  $V_{g \max}$ .
- ▶ Setting range<sup>1)</sup> for pressure control 20 to 280 bar (**3**). Standard is 280 bar.
- ▶ Setting range for differential pressure 10 - 22 bar(**2**) Standard is 20 bar.

Unloading port **X** to the reservoir results in a zero stroke (standby) pressure which is approx. 1 to 2 bar higher than the defined differential pressure  $\Delta p$ , however system influences are not taken into account.

### ▼ Characteristic curve DRG

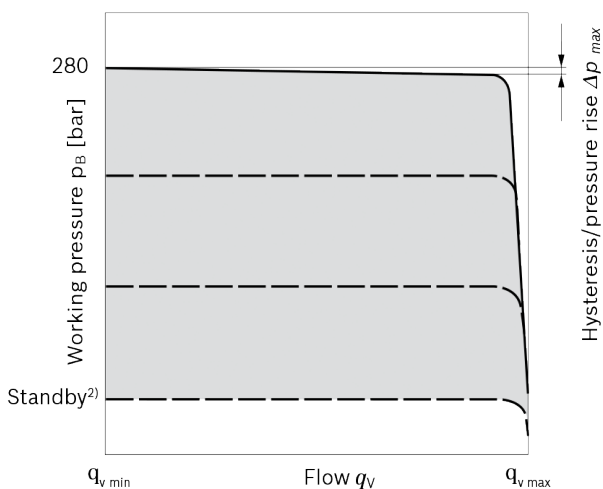

Characteristic curve valid for  $n_1 = 1500$  rpm and  $t_{\text{fluid}} = 50$  °C.

- 1) In order to prevent damage to the pump and the system, the permissible setting range must not be exceeded. The range of possible settings at the valve is higher.
- 2) Zero stroke from pressure setting  $\Delta p$  on controller (**2**)

### ▼ Circuit diagram DRG nominal size 18 to 100

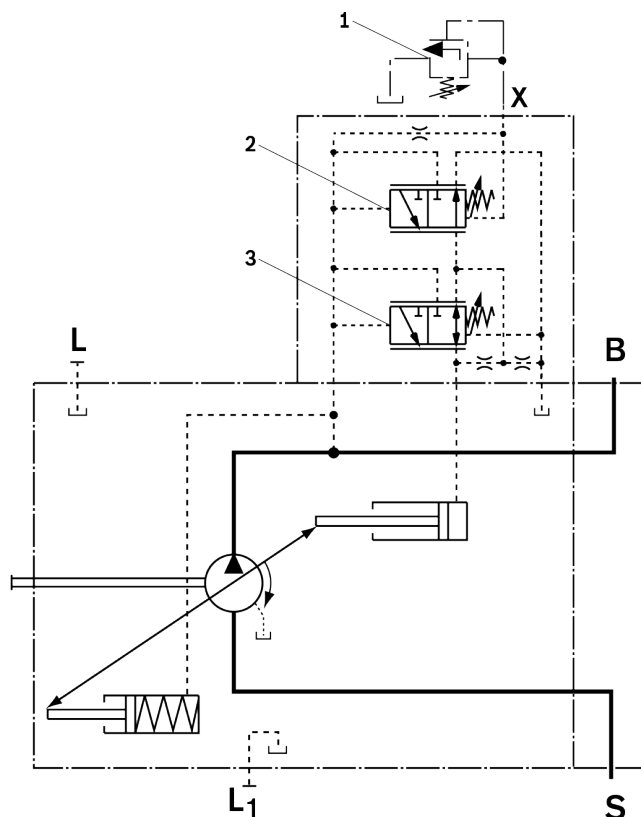

- 1 The separate pressure relief valve and the line are not included in the scope of delivery.
- 2 Remote controlled pressure cut-off (**G**).
- 3 Pressure controller (**DR**)

### ▼ Circuit diagram, size 140

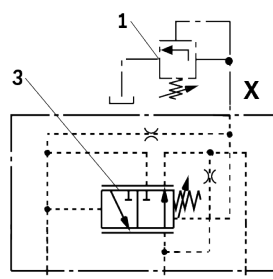

### Controller data

NG	18	28	45	71	88	100	140	
Pressure increase	$\Delta p$ [bar]	4	4	6	8	9	10	12
Hysteresis and repeatability	$\Delta p$ [bar]	maximum 3						
Control fluid consumption	[l/min]	maximum approx. 4.5						

## DFR / DFR1 / DRSC – Pressure and flow controller

In addition to the pressure controller function (see page 11), a variable orifice (e.g. directional valve) is used to adjust the differential pressure upstream and downstream of the orifice. This is used to control the pump flow. The pump flow is equal to the actual hydraulic fluid quantity required by the consumer. With all controller combinations, the  $V_g$  reduction has priority.

- ▶ Basic position in depressurized state:  $V_{g \max}$ .
- ▶ Setting range<sup>1)</sup> to 280 bar standard is 280 bar.
- ▶ DR pressure controller data see page 11

### Notice

- ▶ The DFR1 and DRSC versions have no unloading between **X** and the reservoir. Unloading the LS-pilot line must be possible in the valve system. Because of the flushing function of the flow controller in the DRS control valve, sufficient unloading of the **X**-line must also be provided. If this unloading of the **X** line does not have to be guaranteed, the DRSC control valve must be used.

### ▼ Characteristic curve

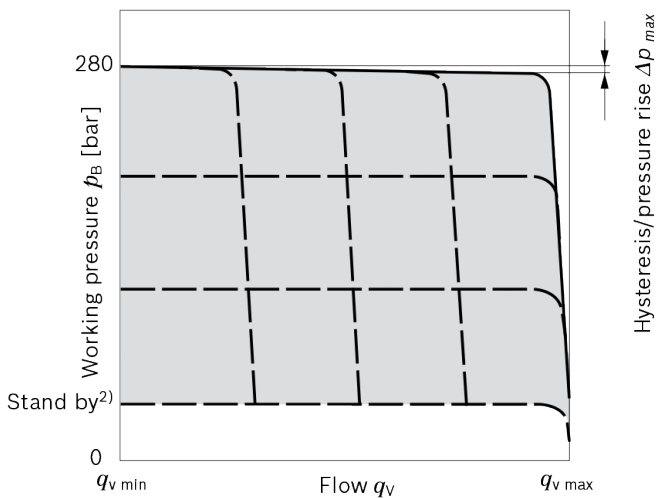

### ▼ Characteristic curve at variable rotational speed

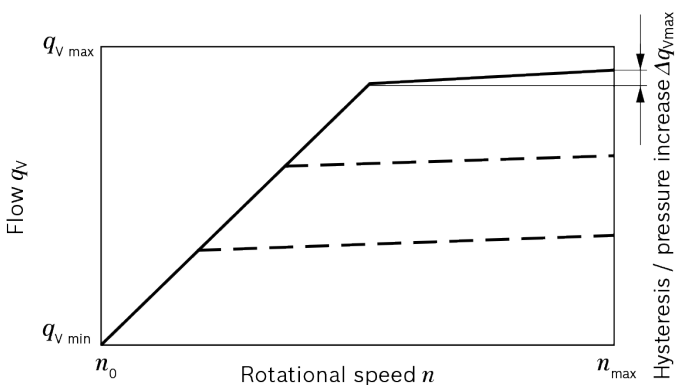

Characteristic curve valid at  $n_1 = 1500$  rpm and  $\theta_{\text{fluid}} = 50$  °C.

### ▼ Circuit diagram DFR size 18 to 100

Plugged with DFR1 / DRSC

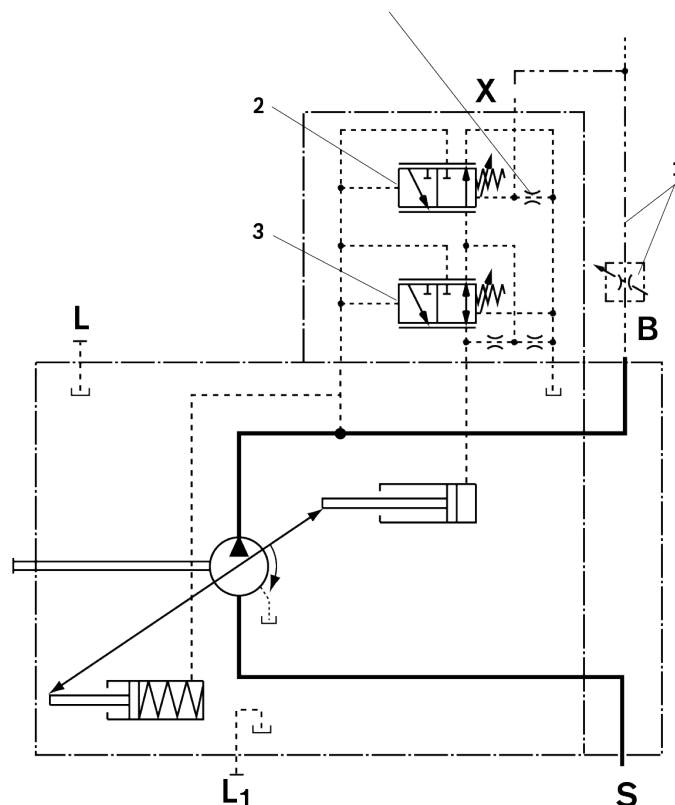

### ▼ Circuit diagram, size 140

Plugged with DFR1 / DRSC

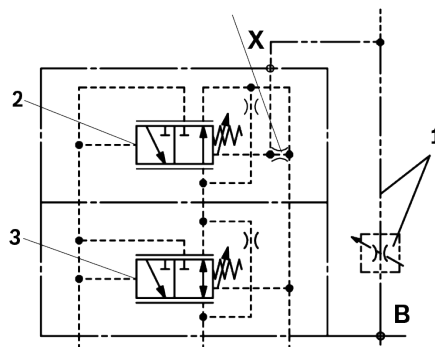

- 1 The metering orifice (control block) and the line is not included in the scope of delivery.
- 2 Pressure and flow controller (**FR**).
- 3 Pressure controller (**DR**)

For further information see page 14

- 1) In order to prevent damage to the pump and the system, the permissible setting range must not be exceeded. The range of possible settings at the valve is higher.
- 2) Zero stroke from pressure setting  $\Delta p$  on controller (2)

**Differential pressure  $\Delta p$ :**

- ▶ Standard setting: 14 bar  
If another setting is required, please state in plain text.
- ▶ Setting range: 14 bar to 22 bar

Unloading port **X** to the reservoir results in a zero stroke (standby) pressure which is approx. 1 to 2 bar higher than the defined differential pressure  $\Delta p$ , however, system influences are not taken into account.

**Controller data**

DR pressure controller data see page 11.

Maximum flow deviation measured at drive speed

$n = 1500$  rpm.

<b>NG</b>		<b>18</b>	<b>28</b>	<b>45</b>	<b>71</b>	<b>88</b>	<b>100</b>	<b>140</b>
Flow deviation	$\Delta q_{Vmax}$ [l/min]	0.9	1.0	1.8	2.8	3.4	4.0	6.0
Hysteresis and repeatability	$\Delta p$ [bar]	maximum 4						
Control fluid consumption	[l/min]	maximum approx. 3 to 4.5 (DFR) maximum approx. 3 (DFR1/DRSC)						

## DFLR – Pressure, flow and power control

Pressure controller equipped like DR(G), see page 11 (12).  
 Flow controller equipped like DFR, DFR1, see page 13.  
 In order to achieve a constant drive torque with varying working pressures, the swivel angle and with it the output flow from the axial piston pump is varied so that the product of flow and pressure remains constant.  
 Flow controller is possible below the power control curve.

### ▼ Characteristic curve and torque characteristic

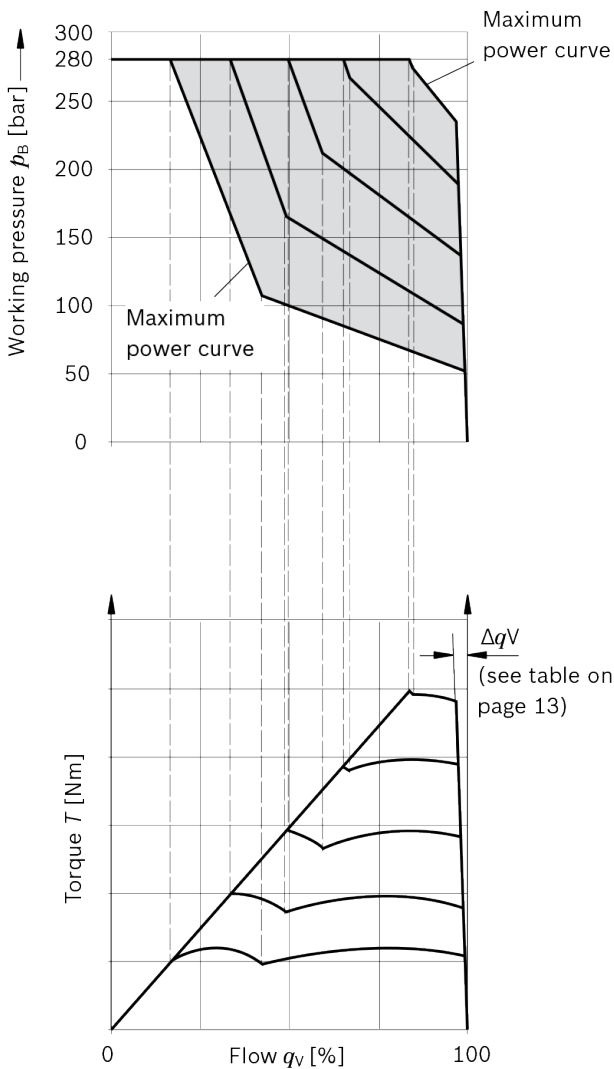

Beginning of control 50 bar

When ordering please state the power characteristics to be set at the factory in plain text, e.g. 20 kW at 1500 rpm.

### ▼ Circuit diagram, sizes 28 to 100

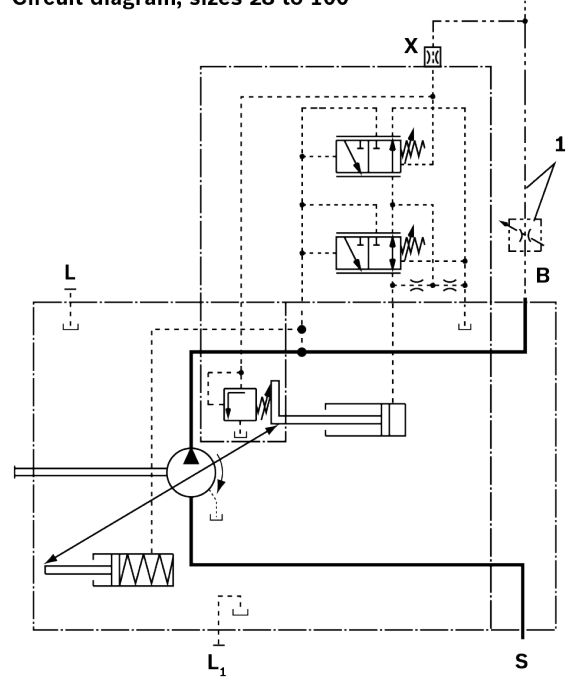

### ▼ Circuit diagram, size 140

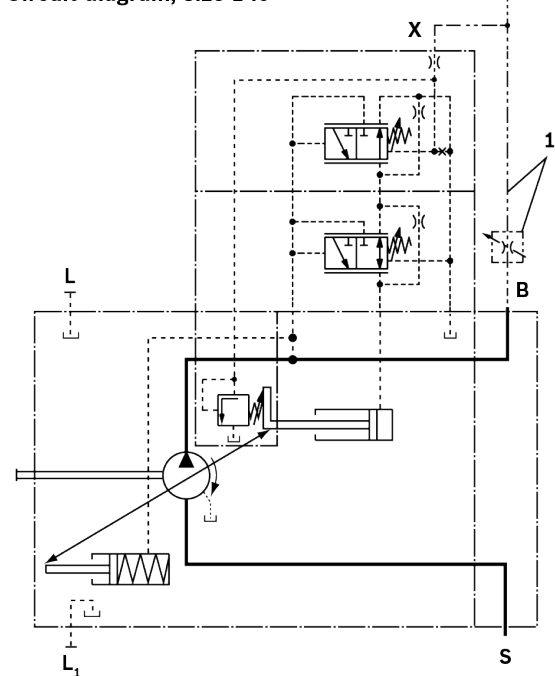

**1** The metering orifice (control block) and the line is not included in the scope of delivery.

### Controller data

- ▶ For technical data of pressure controller DR see page 11.
- ▶ For technical data of flow controller FR see page 14.
- ▶ Control fluid consumption approx. 5.5 l/min max.

# ED – Electro-hydraulic pressure control

The ED valve is set to a certain pressure by a specified variable solenoid current.

With changes on the consumer (load pressure), this causes an increase or decrease in the pump swivel angle (flow) in order to maintain the electrically set pressure level.

The pump thus only delivers as much hydraulic fluid as the consumers can take. The desired pressure level can be set steplessly by varying the solenoid current.

As the solenoid current signal drops towards zero, the pressure will be limited to  $p_{max}$  by an adjustable hydraulic pressure cut-off (secure fail safe function in case of power failure, e.g. for fan speed control). The response time characteristic curve of the ED control was optimized for the use as a fan drive system.

When ordering, specify the type of application in plain text.

### ▼ Static current-pressure characteristic curve ED

(negative characteristic curve measured with pump in zero stroke)

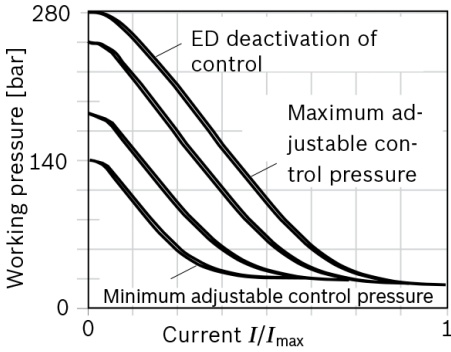

Hysteresis static < 3 bar.

### ▼ Flow-pressure characteristic curve

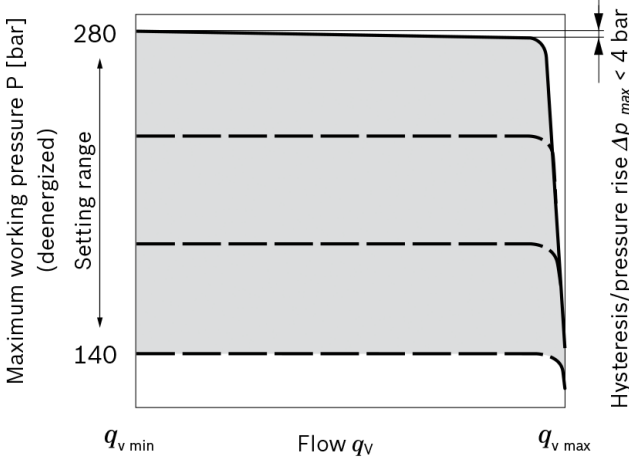

Characteristic curves valid at  $n_1 = 1500$  rpm and  $t_{fluid} = 50$  °C.

Control fluid consumption: 3 to 4.5 l/min.

For standby standard setting, see diagram on right, other values on request.

### ▼ Influence of the pressure setting on standby (maximally energized)

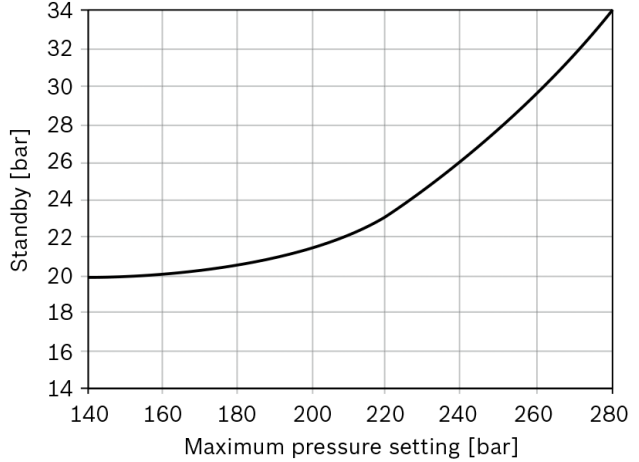

### ▼ Circuit diagram ED71/ED72

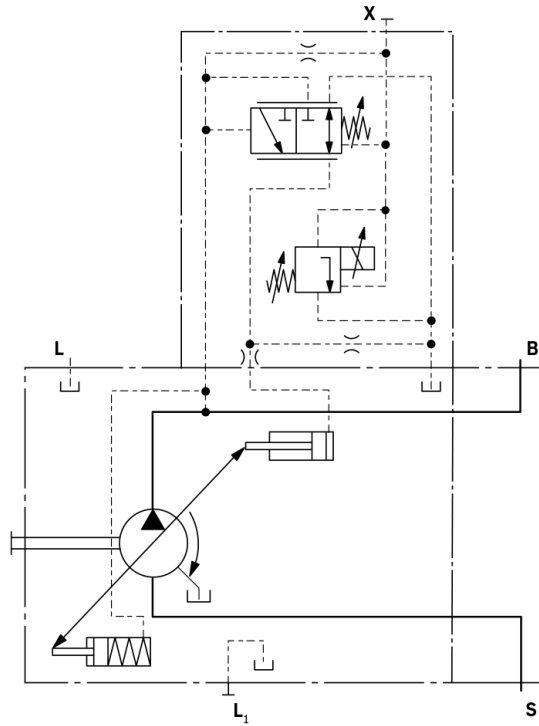

Technical data, solenoid	ED71	ED72
Voltage	12 V ( $\pm 20\%$ )	24 V ( $\pm 20\%$ )
Control current		
Start of control at $p_{max}$	100 mA	50 mA
Start of control at $p_{min}$	1200 mA	600 mA
Current limit	1.54 A	0.77 A
Nominal resistance (at 20 °C)	5.5 $\Omega$	22.7 $\Omega$
Dither frequency	100 to 200 Hz	100 to 200 Hz
Duty cycle	100%	100%
Electronic controls and type of protection, see page 55		
Operating temperature range at valve	-20 °C to +115 °C	

## ER – Electro-hydraulic pressure control

The ER valve is set to a certain pressure by a specified variable solenoid current.

When a change is made at the consumer (load pressure), the position of the control spool will shift.

This causes an increase or decrease in the pump swivel angle (flow) in order to maintain the electrically set pressure level.

The pump thus only delivers as much hydraulic fluid as the consumers can take. The desired pressure level can be set steplessly by varying the solenoid current.

As the solenoid current signal drops towards zero, the pressure will be limited to  $p_{\min}$  (stand by).

### ▼ Current-pressure characteristic curve

(positive characteristic curve measured with pump in zero stroke)

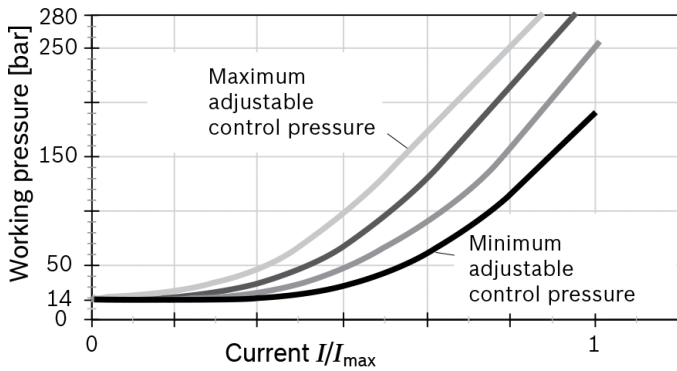

Hysteresis static < 3 bar.

### ▼ Flow-pressure characteristic curve

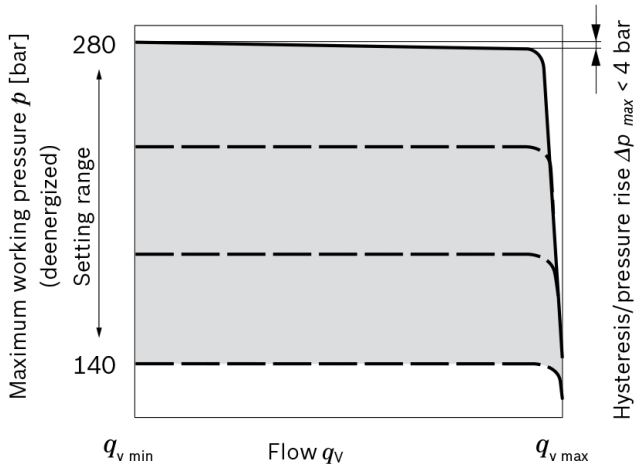

Characteristic curve valid at  $n_1 = 1500$  rpm and  $\theta_{\text{fluid}} = 50$  °C.

- ▶ Control fluid consumption: 3 to 4.5 l/min.
- ▶ Standby standard setting 14 bar. Other values on request.
- ▶ Influence of pressure setting on stand-by  $\pm 2$  bar.

### ▼ Circuit diagram

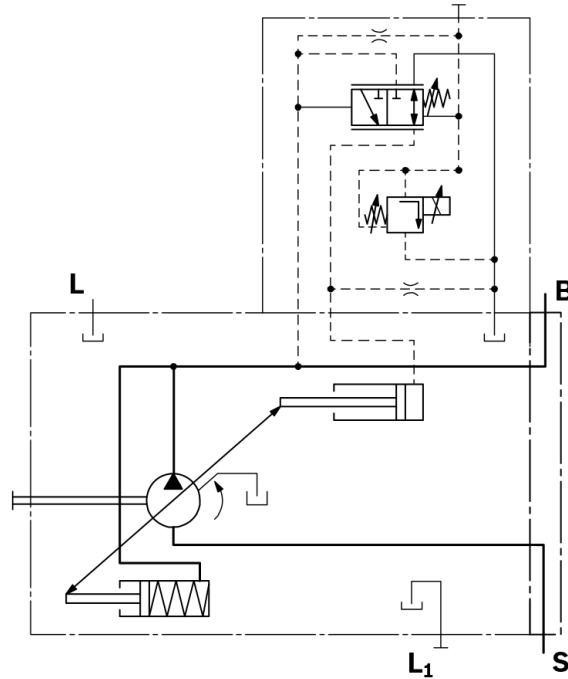

Technical data, solenoid	ER71	ER72
Voltage	12 V ( $\pm 20\%$ )	24 V ( $\pm 20\%$ )
Control current		
Start of control at $p_{\min}$	100 mA	50 mA
End of control at $p_{\max}$	1200 mA	600 mA
Current limit	1.54 A	0.77 A
Nominal resistance (at 20 °C)	5.5 $\Omega$	22.7 $\Omega$
Dither frequency	100 to 200 Hz	100 to 200 Hz
Duty cycle	100%	100%
Electronic controls and type of protection, see page 55		
Operating temperature range at valve -20 °C to +115 °C		

### Project planning note!

Excessive current levels ( $I > 1200$  mA at 12 V or  $I > 600$  mA at 24 V) to the ER solenoid can result in undesired pressure increases which can lead to pump or system damage. Therefore:

- ▶ Use  $I_{\max}$  current limiter solenoids.
- ▶ An intermediate plate pressure controller can be used to protect the pump in the event of overflow.

# Dimensions, size 18

DFR / DFR1 / DRSC – Pressure and flow control, hydraulic; clockwise rotation, version: SAE ports

▼ Port plate 62

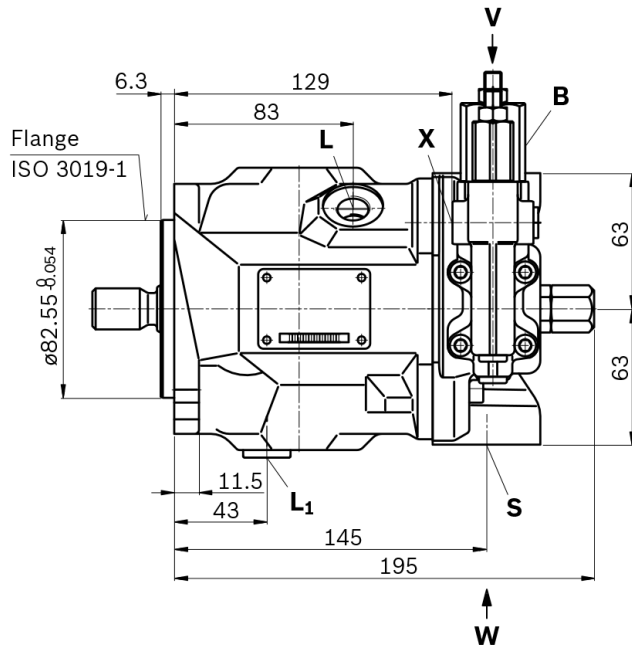

Valve mounting for counter-clockwise rotation

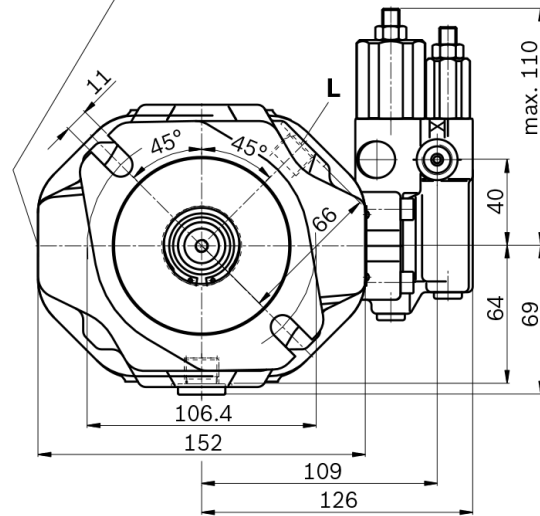

Detail V

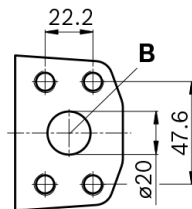

Detail W

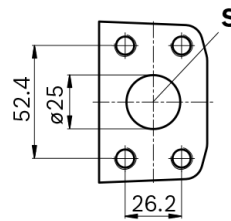

▼ Splined shaft 3/4 in (SAE J744)

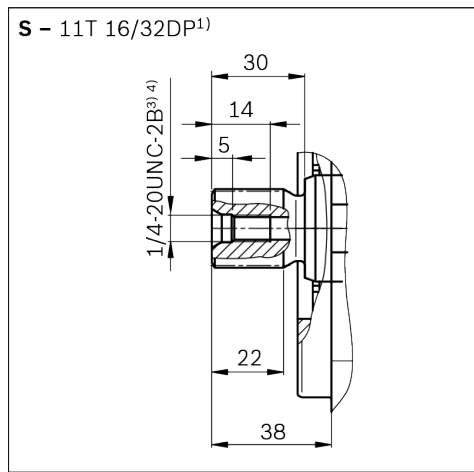

▼ Splined shaft 3/4 in (SAE J744)

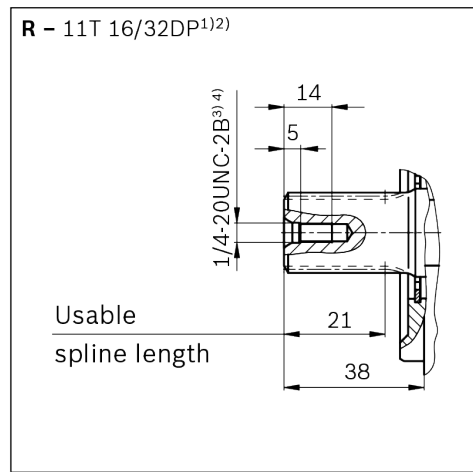

▼ Splined shaft 5/8 in (SAE J744)

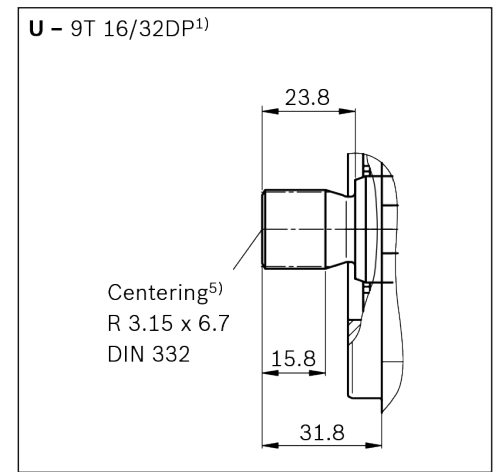

Ports - version metric port plate 12		Standard	Size <sup>4)</sup>	$p_{\max \text{ abs}}$ [bar] <sup>6)</sup>	State <sup>10)</sup>
<b>B</b>	Working port (standard pressure series) Fastening thread	SAE J518 <sup>7)</sup> DIN 13	3/4 in M10 × 1.5; 17 deep	350	O
<b>S</b>	Suction port (standard pressure series) Fastening thread	SAE J518 <sup>7)</sup> DIN 13	1 in M10 × 1.5; 17 deep	10	O
<b>L</b>	Drain port	DIN 3852 <sup>8)</sup>	M16 × 1.5; 12 deep	2	O <sup>9)</sup>
<b>L<sub>1</sub></b>	Drain port	DIN 3852 <sup>8)</sup>	M16 × 1.5; 12 deep	2	X <sup>9)</sup>
<b>X</b>	Pilot pressure	DIN 3852	M14 × 1.5; 12 deep	350	O
<b>X</b>	Pilot pressure with DG-control	DIN ISO 228	G1/4 in; 12 deep	350	O

Ports - version SAE port plate 62		Standard	Size <sup>4)</sup>	$p_{\max \text{ abs}}$ [bar] <sup>6)</sup>	State <sup>10)</sup>
<b>B</b>	Working port (standard pressure series) Fastening thread	SAE J518 ASME B1.1	3/4 in 3/8-16 UNC-2B; 20 deep	350	O
<b>S</b>	Suction port (standard pressure series) Fastening thread	SAE J518 ASME B1.1	1 in 3/8-16 UNC-2B; 20 deep	10	O
<b>L</b>	Drain port	ISO 11926 <sup>8)</sup>	9/16-18 UNF-2B; 12 deep	2	O <sup>9)</sup>
<b>L<sub>1</sub></b>	Drain port	ISO 11926 <sup>8)</sup>	9/16-18 UNF-2B; 12 deep	2	X <sup>9)</sup>
<b>X</b>	Pilot pressure	ISO 11926	7/16-20 UNF-2B; 11.5 deep	350	O
<b>X</b>	Pilot pressure with DG-control	DIN ISO 228	G1/4 in; 12 deep	350	O

- 1) Involute spline according to ANSI B92.1a, 30° pressure angle, flat root, side fit, tolerance class 5
- 2) Splines according to ANSI B92.1a, run out of spline is a deviation from standard.
- 3) Thread according to ASME B1.1
- 4) For notes on tightening torques, see the instruction manual
- 5) Coupling axially secured, e.g. with a clamp coupling or radially mounted clamping screw

- 6) Depending on the application, momentary pressure peaks can occur. Keep this in mind when selecting measuring devices and fittings.
- 7) Metric fastening thread is a deviation from standard.
- 8) The countersink can be deeper than as specified in the standard.
- 9) Depending on the installation position, L or L<sub>1</sub> must be connected (also see installation instructions starting on page 56).
- 10) O = Must be connected (plugged when delivered)  
X = Plugged (in normal operation)

▼ DG – Two-point control, direct operated

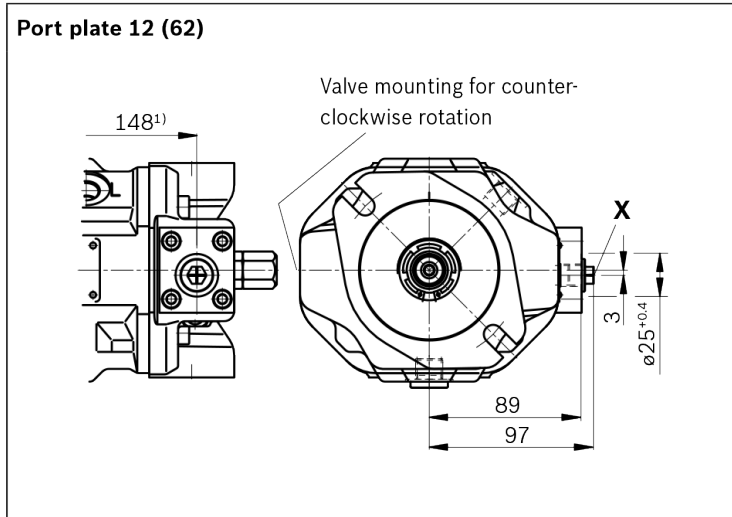

▼ DR – Pressure controller

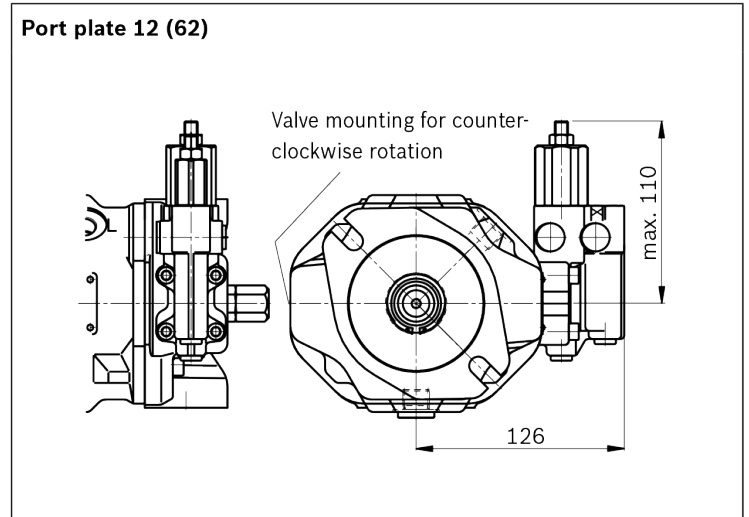

▼ DRG – Pressure controller, remote controlled

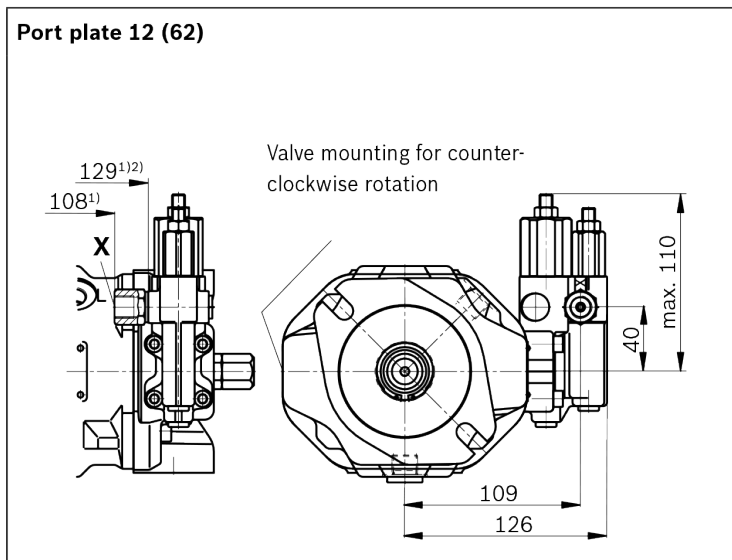

▼ ED7.,ER7. – Electro-hydraulic pressure control

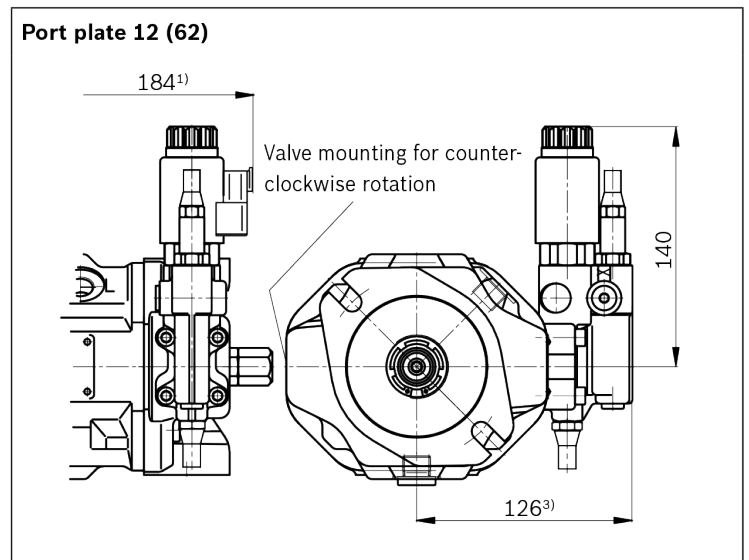

# Dimensions, size 28

DFR / DFR1 / DRSC – Pressure and flow control, hydraulic; clockwise rotation, version: Ports metric

▼ Port plate 12

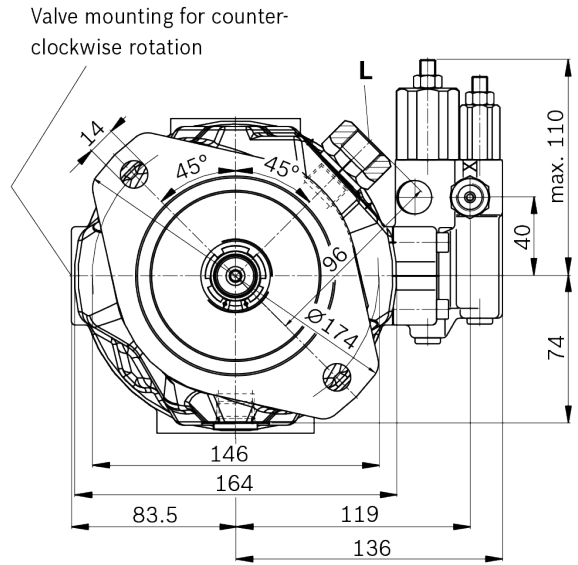
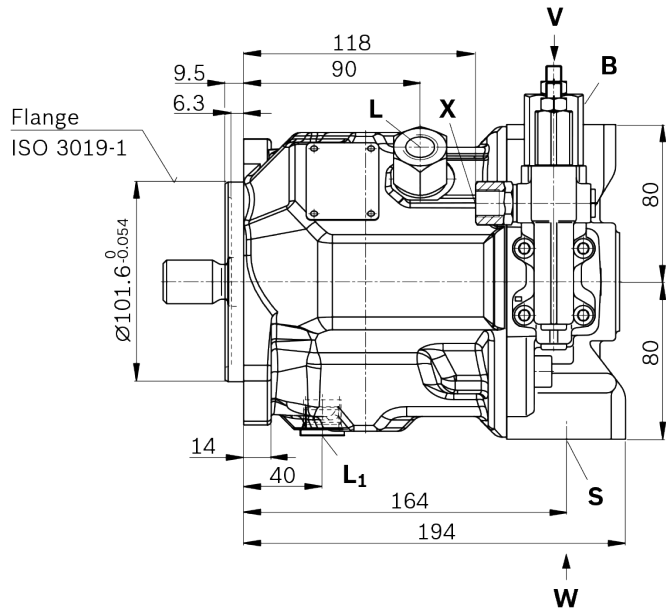

Detail V

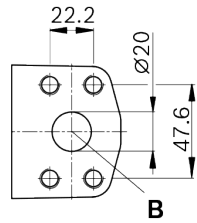

Detail W

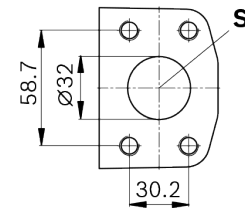

View Z

▼ Port plate 11

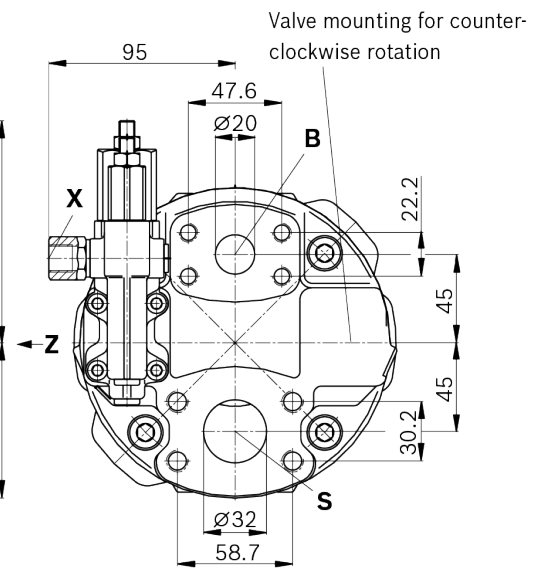
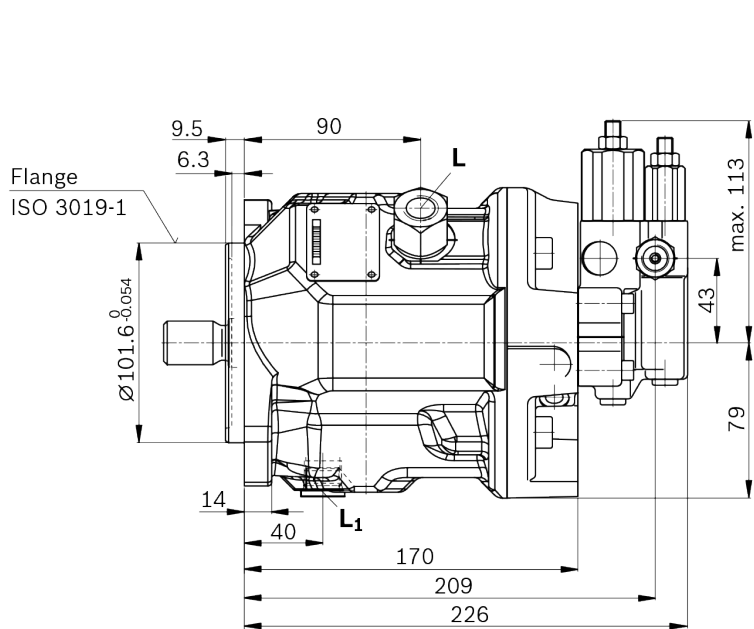

## Dimensions, size 28

DFR / DFR1 / DRSC – Pressure and flow control, hydraulic; clockwise rotation, version: SAE ports

### ▼ Port plate 62

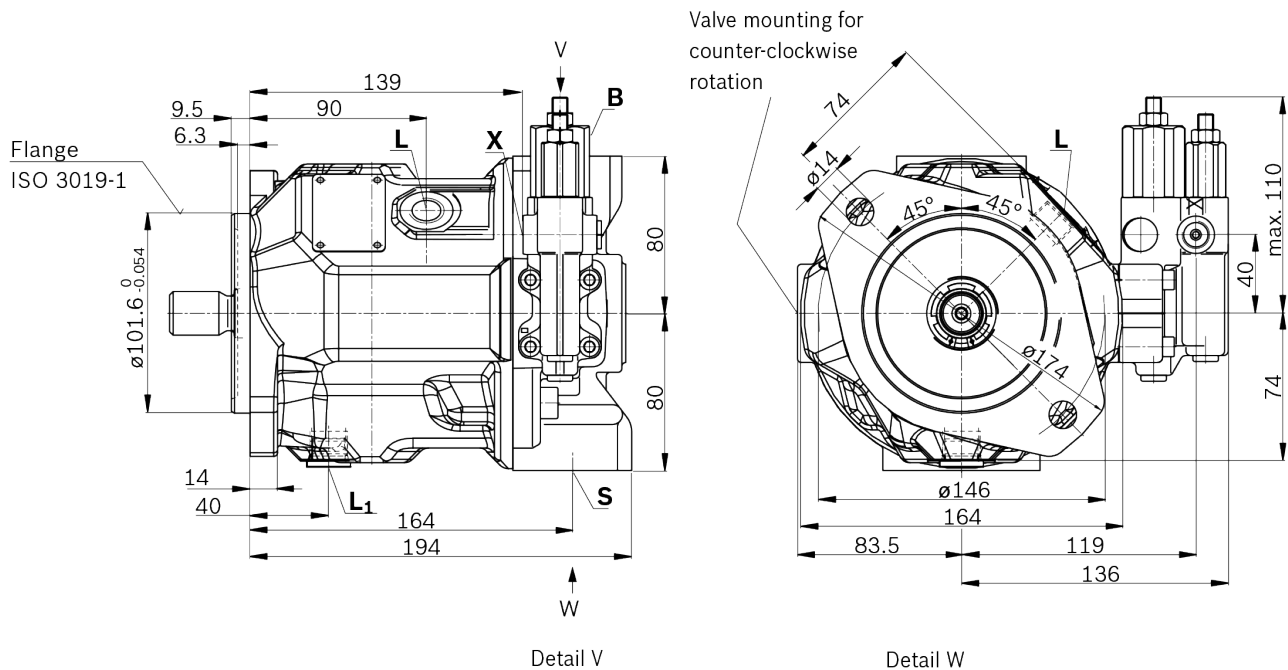

### ▼ Port plate 61

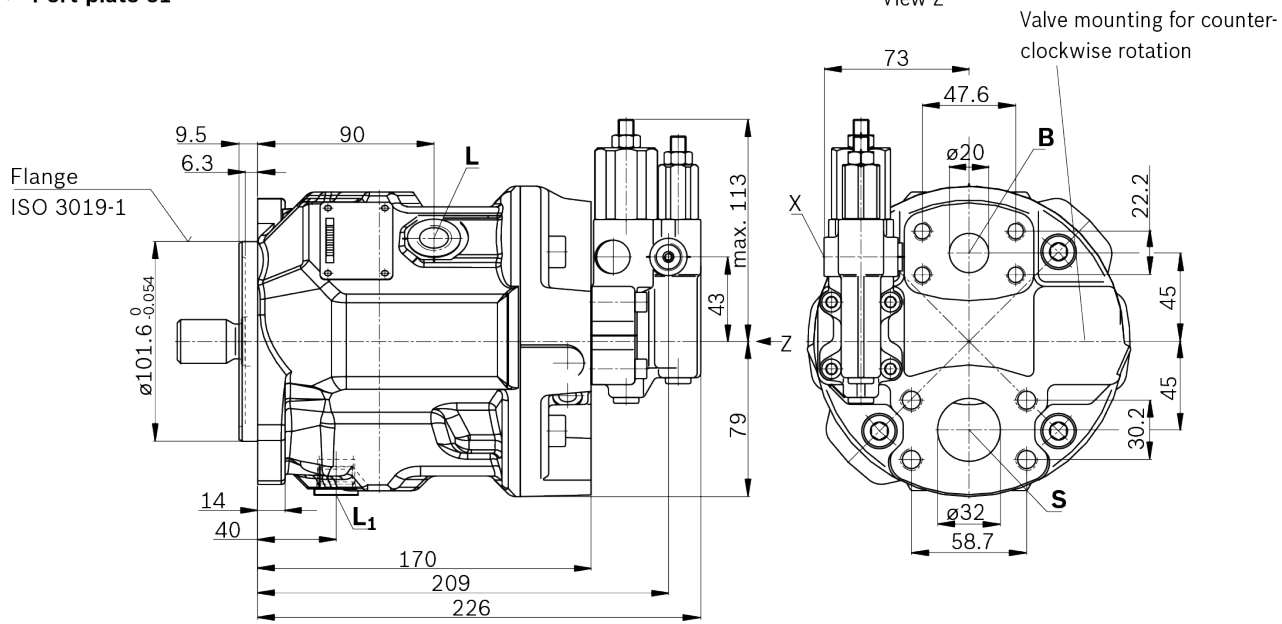

▼ Splined shaft 7/8 in (SAE J744)

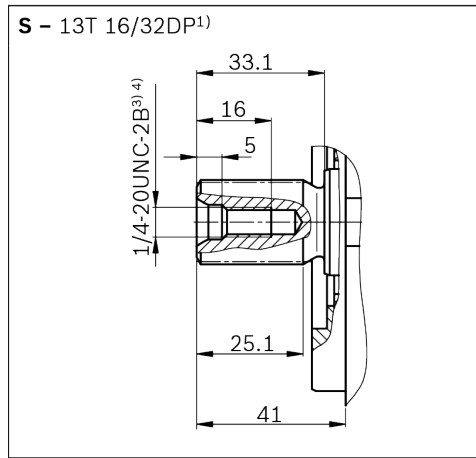

▼ Splined shaft 7/8 in (SAE J744)

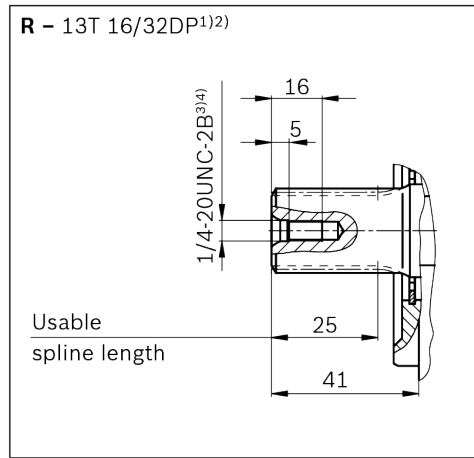

▼ Splined shaft 3/4 in (SAE J744)

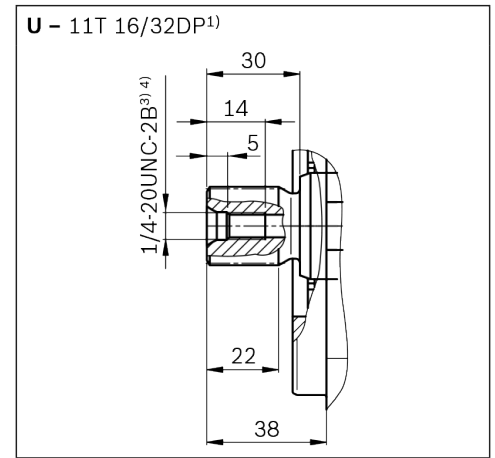

▼ Splined shaft 3/4 in (SAE J744)

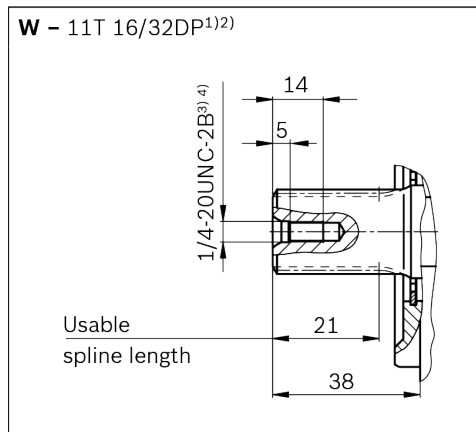

Ports - version metric port plate 11/12		Standard	Size <sup>4)</sup>	$p_{\max \text{ abs}}$ [bar] <sup>5)</sup>	State <sup>9)</sup>
<b>B</b>	Working port (standard pressure series) Fastening thread	SAE J518 <sup>6)</sup> DIN 13	3/4 in M10 × 1.5; 17 deep	350	O
<b>S</b>	Suction port (standard pressure series) Fastening thread	SAE J518 <sup>6)</sup> DIN 13	1 1/4 in M10 × 1.5; 17 deep	10	O
<b>L</b>	Drain port	DIN 3852 <sup>7)</sup>	M18 × 1.5; 12 deep	2	O <sup>8)</sup>
<b>L<sub>1</sub></b>	Drain port	ISO 11926 <sup>7)</sup>	3/4-16 UNF-2B; 14 deep	2	X <sup>8)</sup>
<b>X</b>	Pilot pressure	DIN 3852	M14 × 1.5; 12 deep	350	O
<b>X</b>	Pilot pressure with DG-control	DIN ISO 228	G1/4 in; 12 deep	350	O
Ports - version SAE port plate 61/62		Standard	Size <sup>4)</sup>	$p_{\max \text{ abs}}$ [bar] <sup>5)</sup>	State <sup>9)</sup>
<b>B</b>	Working port (standard pressure series) Fastening thread	SAE J518 ASME B1.1	3/4 in 3/8-16 UNC-2B; 20 deep	350	O
<b>S</b>	Suction port (standard pressure series) Fastening thread	SAE J518 ASME B1.1	1 1/4 in 7/16-14 UNC-2B; 24 deep	10	O
<b>L</b>	Drain port	ISO 11926 <sup>7)</sup>	3/4-16 UNF-2B; 14 deep	2	O <sup>8)</sup>
<b>L<sub>1</sub></b>	Drain port	ISO 11926 <sup>7)</sup>	3/4-16 UNF-2B; 14 deep	2	X <sup>8)</sup>
<b>X</b>	Pilot pressure	ISO 11926	7/16-20 UNC-2B; 11.5 deep	350	O
<b>X</b>	Pilot pressure with DG-control	DIN ISO 228	G1/4 in; 12 deep	350	O

- 1) Involute spline according to ANSI B92.1a, 30° pressure angle, flat root, side fit, tolerance class 5
- 2) Splines according to ANSI B92.1a, run out of spline is a deviation from standard.
- 3) Thread according to ASME B1.1
- 4) For notes on tightening torques, see the instruction manual
- 5) Depending on the application, momentary pressure peaks can occur. Keep this in mind when selecting measuring devices and fittings.

- 6) Metric fastening thread is a deviation from standard.
- 7) The countersink can be deeper than as specified in the standard.
- 8) Depending on the installation position, L or L<sub>1</sub> must be connected (also see installation instructions starting on page 56).
- 9) O = Must be connected (plugged when delivered)  
X = Plugged (in normal operation)

▼ DG – Two-point control, direct operated

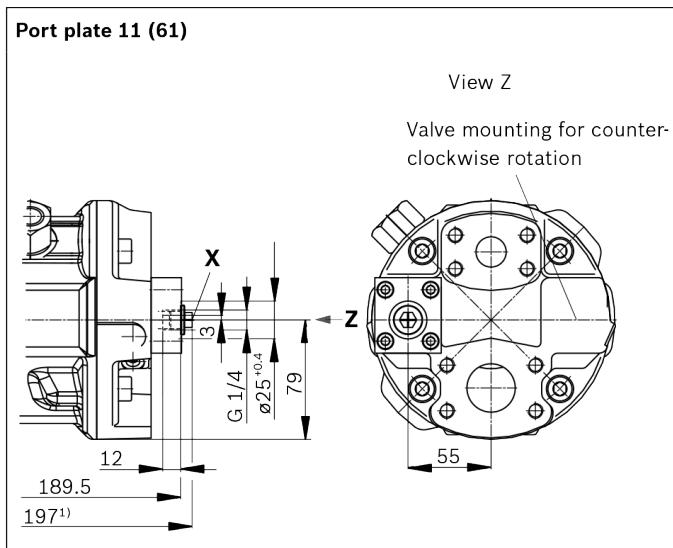

▼ DG – Two-point control, direct operated

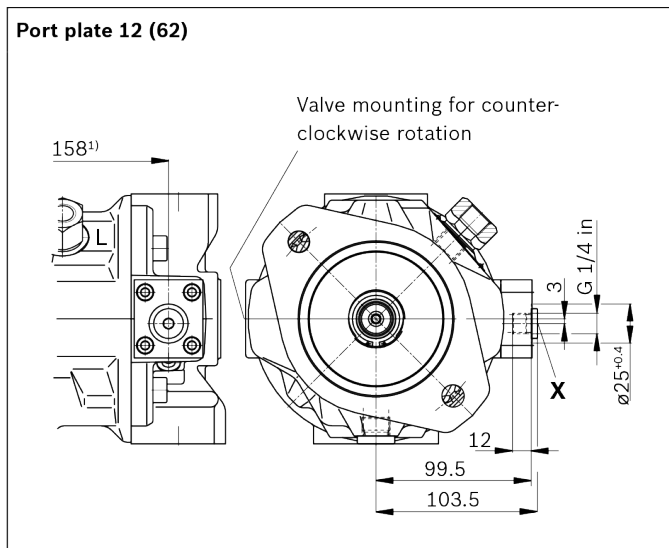

▼ DR – Pressure controller

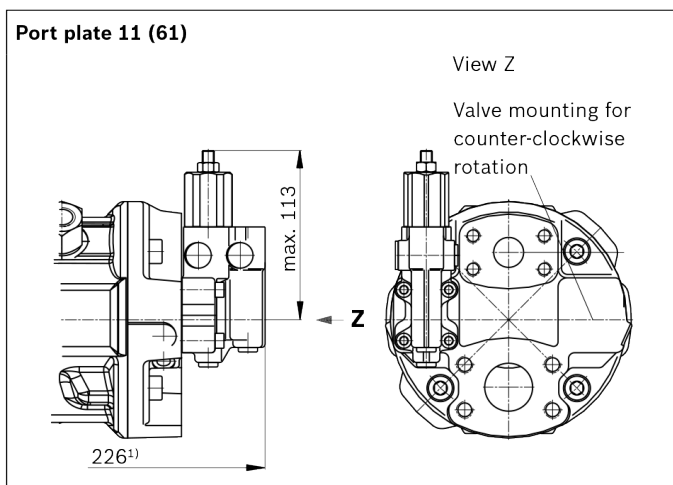

▼ DR – Pressure controller

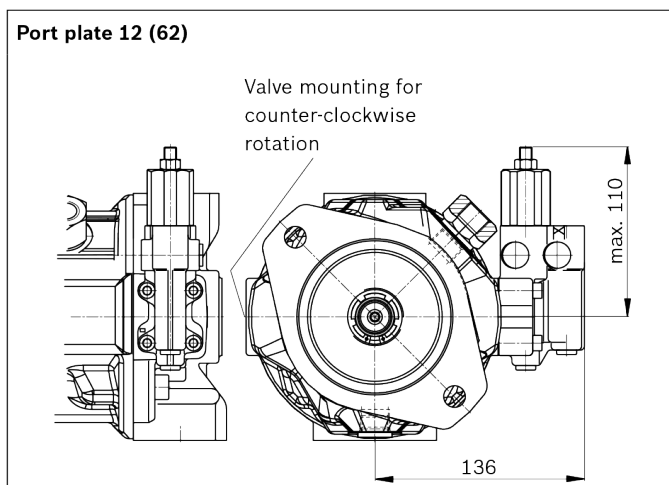

▼ DRG – Pressure controller, remote controlled

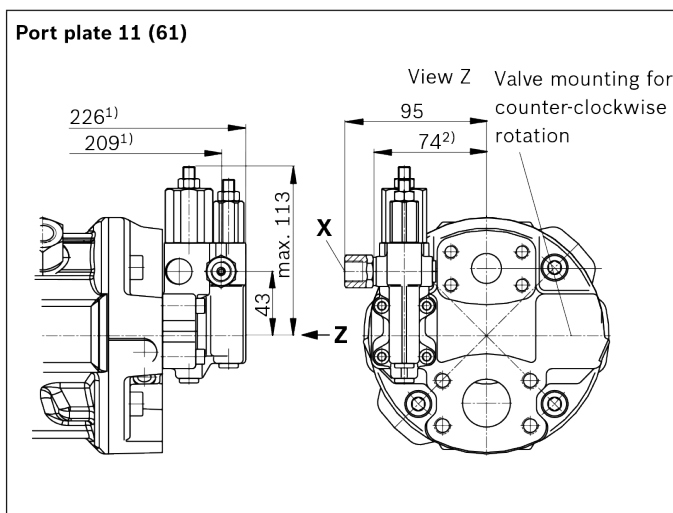

▼ DRG – Pressure controller, remote controlled

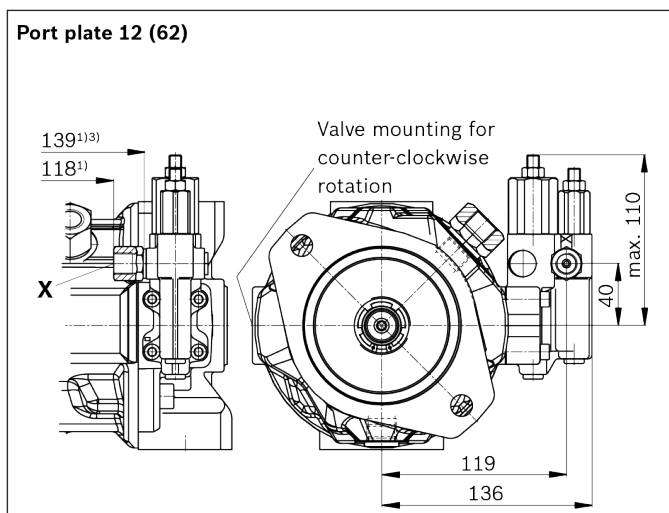

1) To flange surface  
2) For version port plate 61

3) For version port plate 62

▼ DFLR – Pressure, flow and power controller

Port plate 11 (61)

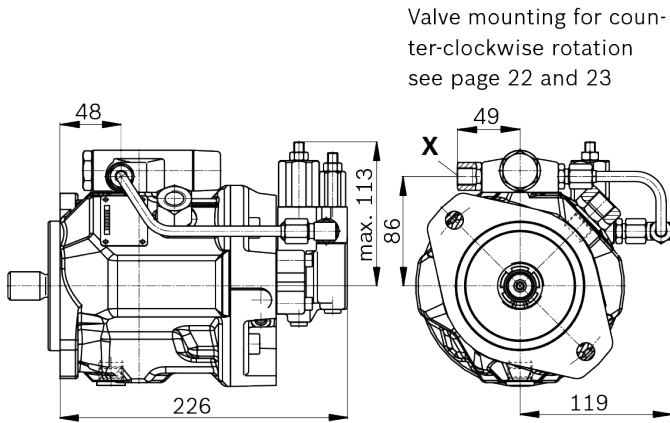

▼ DFLR – Pressure, flow and power controller

Port plate 12 (62)

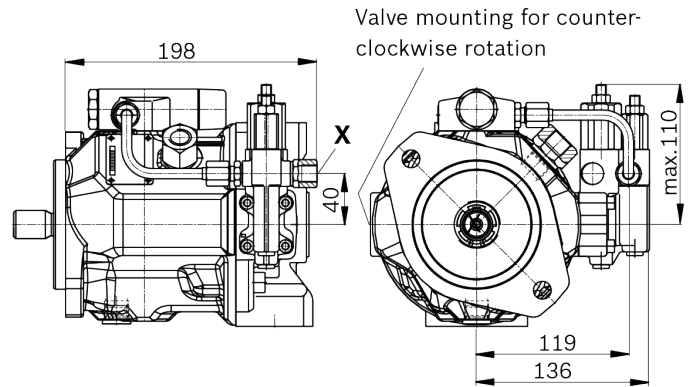

▼ ED7. / ER7. – Electro-hydraulic pressure control

Port plate 11 (61)

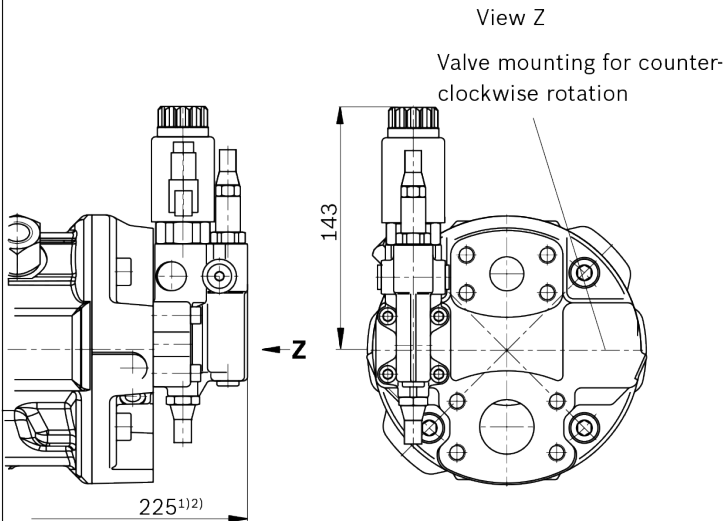

▼ ED7. / ER7. – Electro-hydraulic pressure control

Port plate 12 (62)

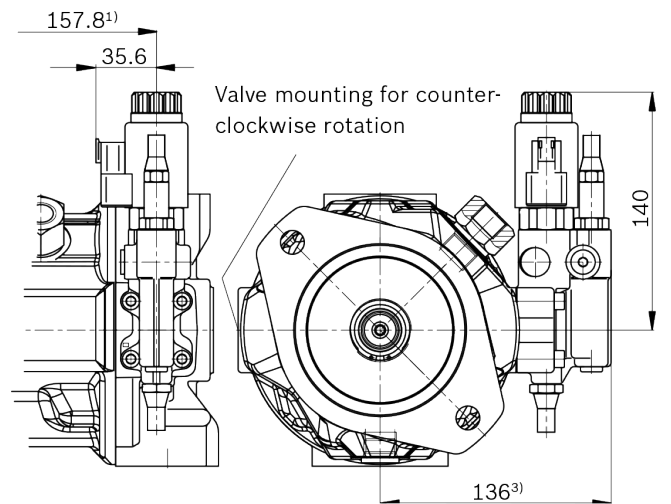

## Dimensions, size 45

DFR / DFR1 / DRSC – Pressure and flow control, hydraulic; clockwise rotation, version: Ports metric

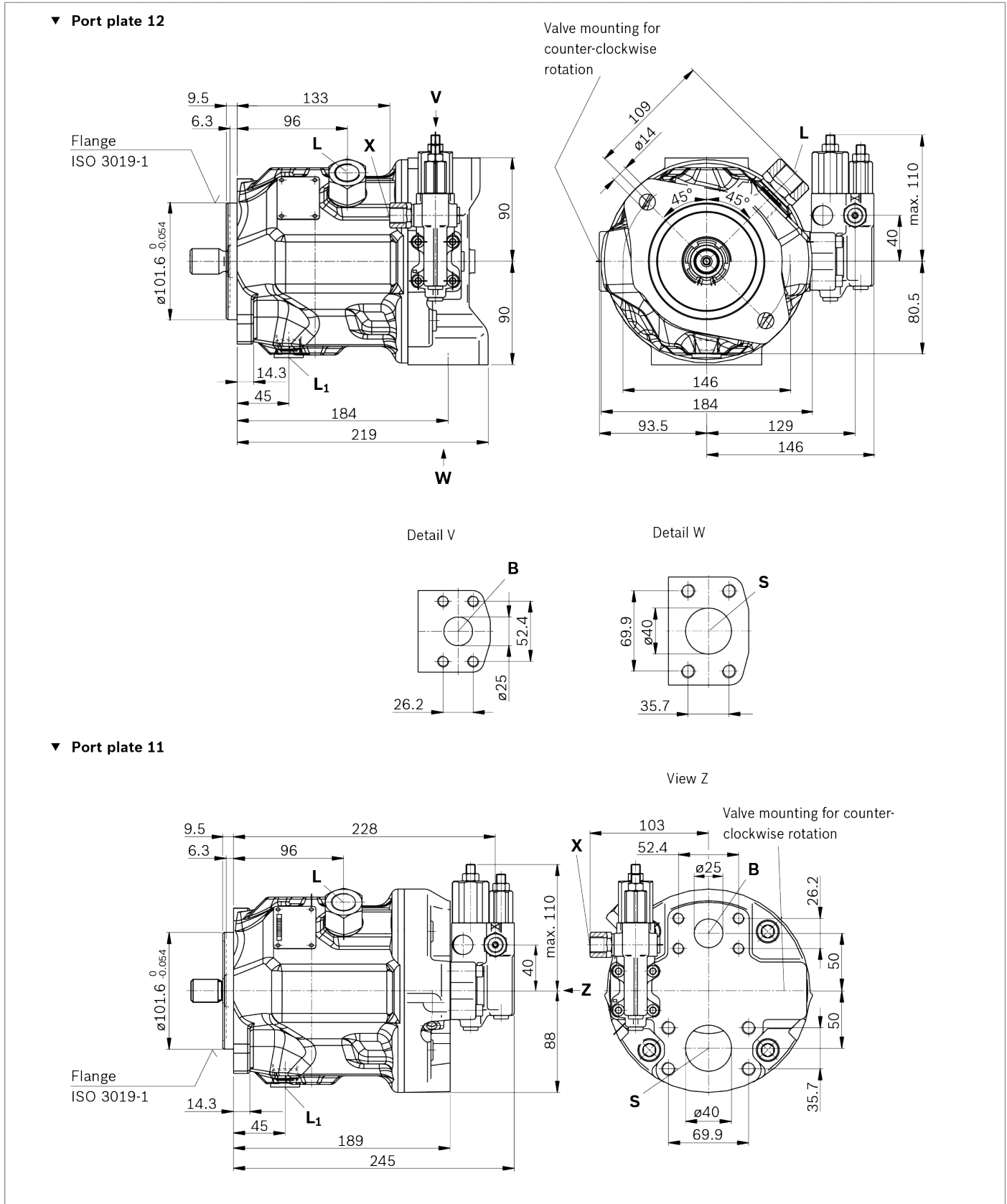

# Dimensions, size 45

DFR / DFR1 / DRSC – Pressure and flow control, hydraulic; clockwise rotation, version: SAE ports

▼ Port plate 62

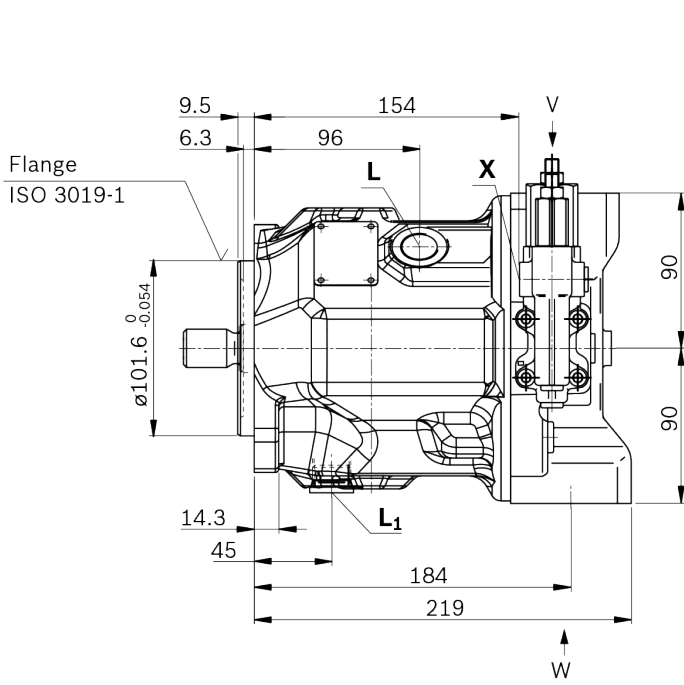

Valve mounting for counter-clockwise rotation

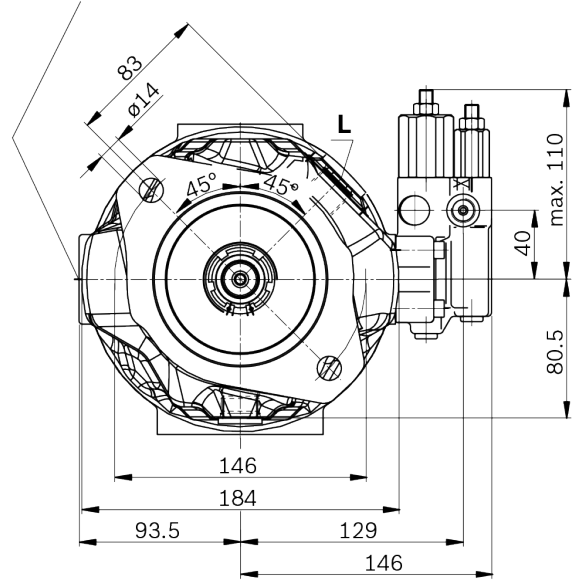

Detail V

Detail W

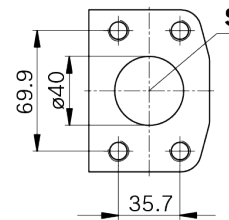
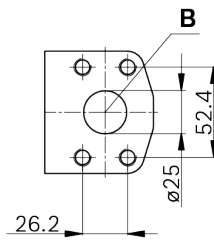

▼ Port plate 61

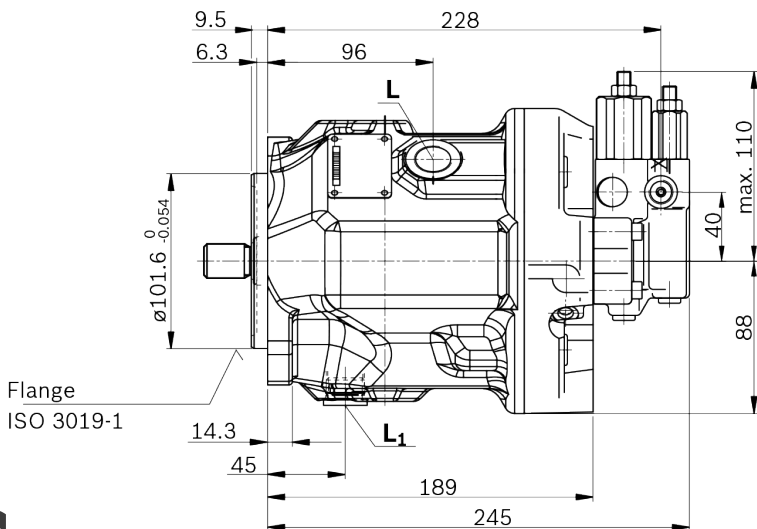

View Z

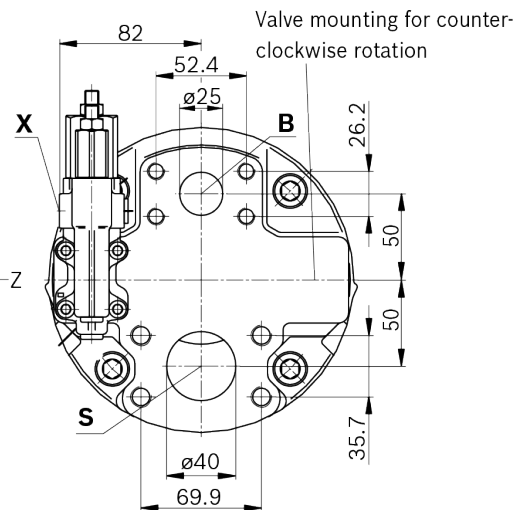

▼ Splined shaft 1 in (SAE J744)

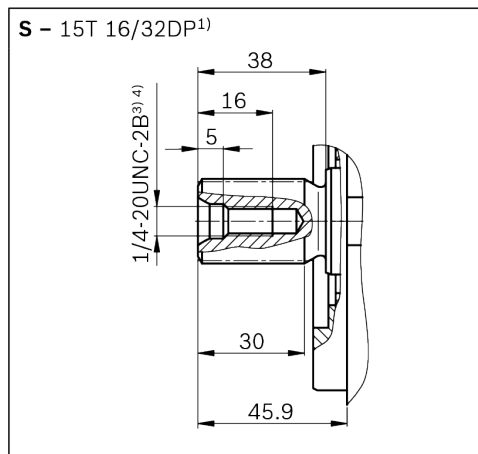

▼ Splined shaft 1 in (SAE J744)

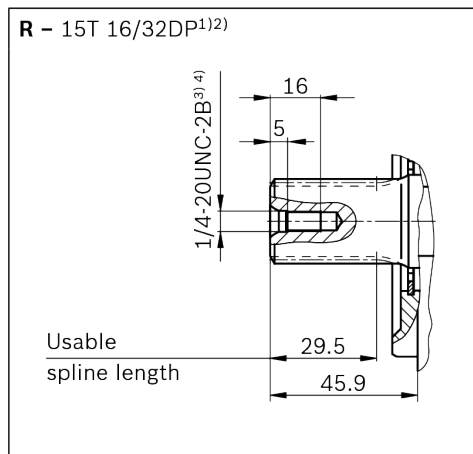

▼ Splined shaft 7/8 in (SAE J744)

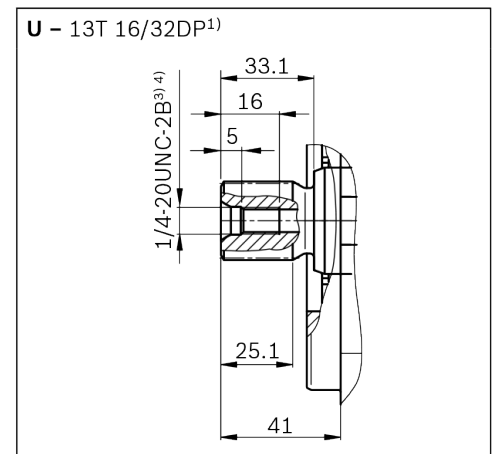

▼ Splined shaft 7/8 in (SAE J744)

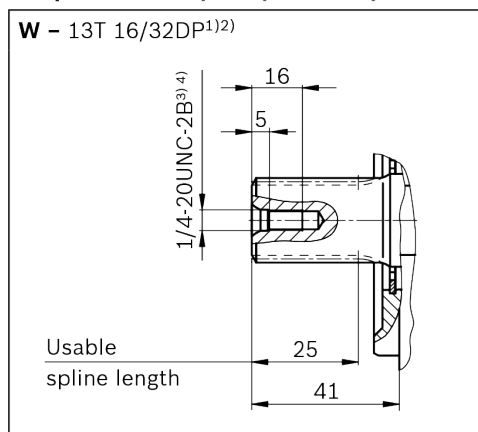

Ports - version metric port plate 11/12		Standard	Size <sup>4)</sup>	$p_{\max \text{ abs}}$ [bar] <sup>5)</sup>	State <sup>9)</sup>
<b>B</b>	Working port (standard pressure series) Fastening thread	SAE J518 <sup>6)</sup> DIN 13	1 in M10 × 1.5; 17 deep	350	O
<b>S</b>	Suction port (standard pressure series) Fastening thread	SAE J518 <sup>6)</sup> DIN 13	1 1/2 in M12 × 1.75; 20 deep	10	O
<b>L</b>	Drain port	DIN 3852 <sup>7)</sup>	M22 × 1.5; 14 deep	2	O <sup>8)</sup>
<b>L<sub>1</sub></b>	Drain port	ISO 11926 <sup>7)</sup>	7/8-14 UNF-2B; 16 deep	2	X <sup>8)</sup>
<b>X</b>	Pilot pressure	DIN 3852	M14 × 1.5; 12 deep	350	O
<b>X</b>	Pilot pressure with DG-control	DIN ISO 228	G1/4 in; 12 deep	350	O
Ports - version SAE port plate 61/62		Standard	Size <sup>4)</sup>	$p_{\max \text{ abs}}$ [bar] <sup>5)</sup>	State <sup>9)</sup>
<b>B</b>	Working port (standard pressure series) Fastening thread	SAE J518 ASME B1.1	1 in 3/8-16 UNC-2B; 17 deep	350	O
<b>S</b>	Suction port (standard pressure series) Fastening thread	SAE J518 ASME B1.1	1 1/2 in 1/2-13 UNC-2B; 20 deep	10	O
<b>L</b>	Drain port	ISO 11926 <sup>7)</sup>	7/8-14 UNF-2B; 16 deep	2	O <sup>8)</sup>
<b>L<sub>1</sub></b>	Drain port	ISO 11926 <sup>7)</sup>	7/8-14 UNF-2B; 16 deep	2	X <sup>8)</sup>
<b>X</b>	Pilot pressure	ISO 11926	7/16-20 UNF-2B; 11.5 deep	350	O
<b>X</b>	Pilot pressure with DG-control	DIN ISO 228	G1/4 in; 12 deep	350	O

1) Involute spline according to ANSI B92.1a, 30° pressure angle, flat root, side fit, tolerance class 5  
 2) Splines according to ANSI B92.1a, run out of spline is a deviation from standard.  
 3) Thread according to ASME B1.1  
 4) For notes on tightening torques, see the instruction manual  
 5) Depending on the application, momentary pressure peaks can occur. Keep this in mind when selecting measuring devices and fittings.

6) Metric fastening thread is a deviation from standard.  
 7) The countersink can be deeper than as specified in the standard.  
 8) Depending on the installation position, L or L<sub>1</sub> must be connected (also see installation instructions starting on page 56).  
 9) O = Must be connected (plugged when delivered)  
 X = Plugged (in normal operation)

▼ DG – Two-point control, direct operated

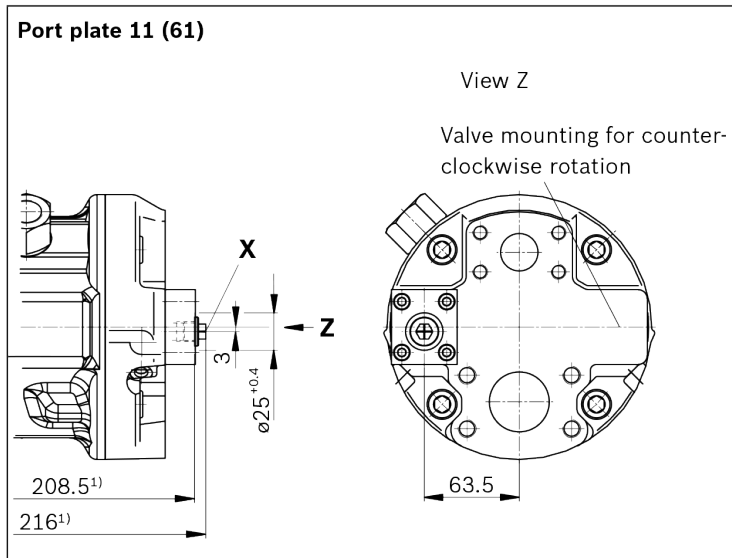

▼ DG – Two-point control, direct operated

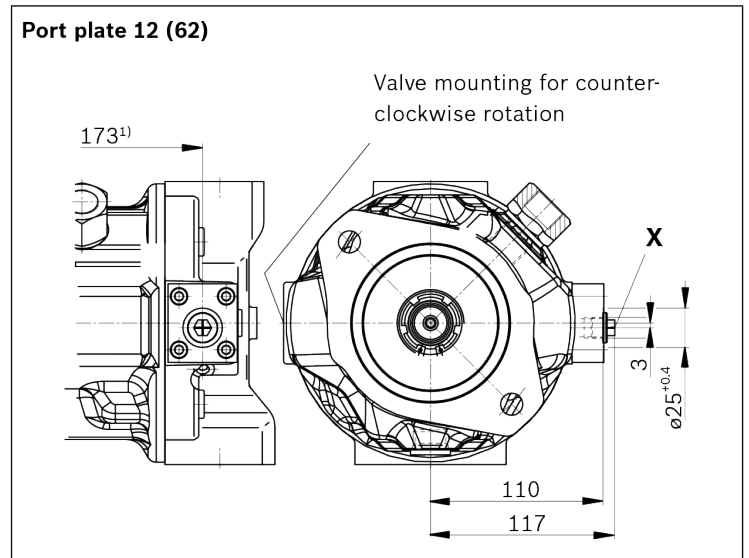

▼ DR – Pressure controller

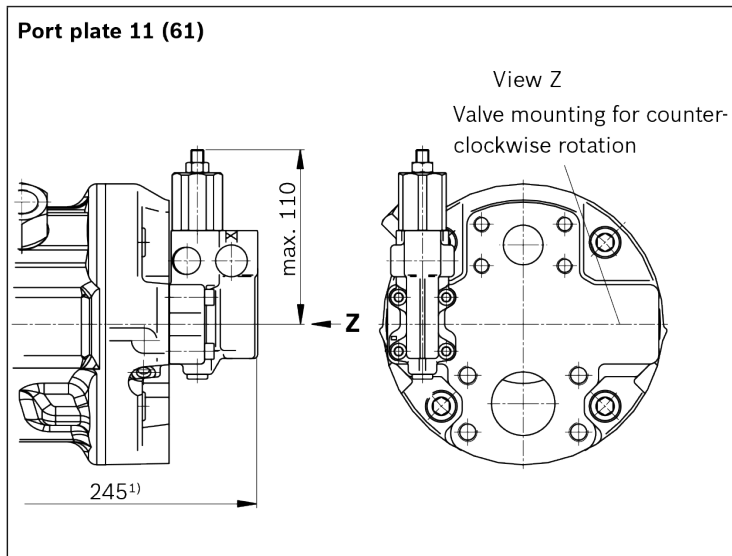

▼ DR – Pressure controller

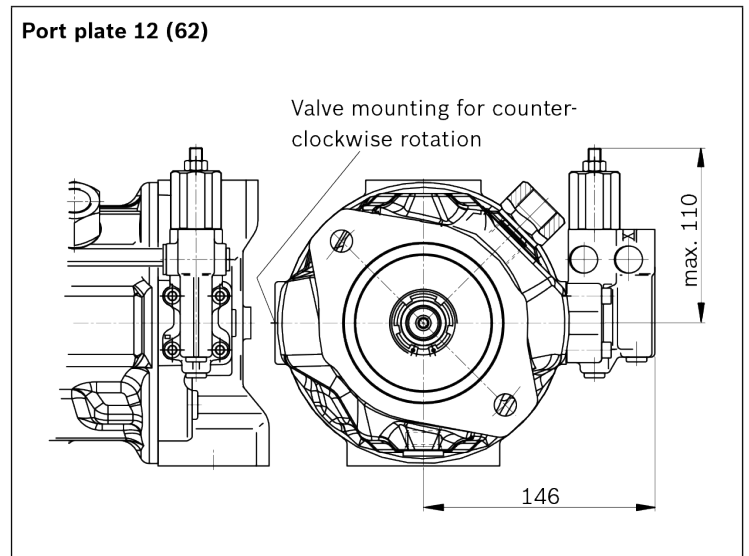

▼ DRG – Pressure controller, remote controlled

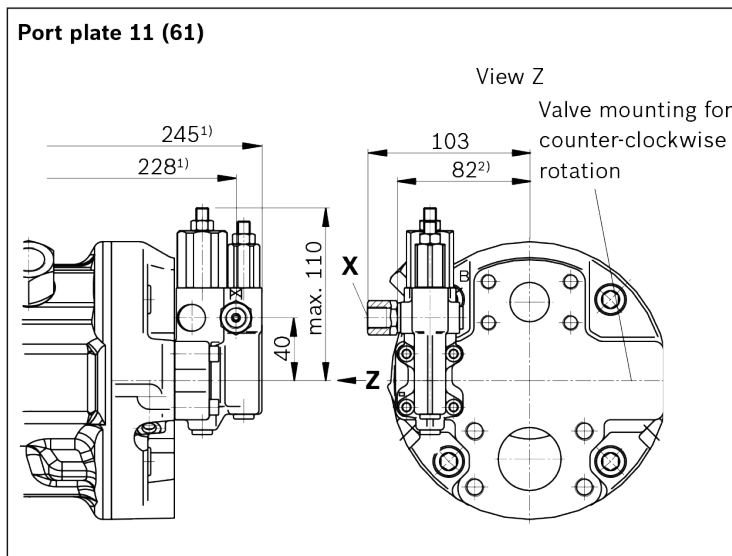

▼ DRG – Pressure controller, remote controlled

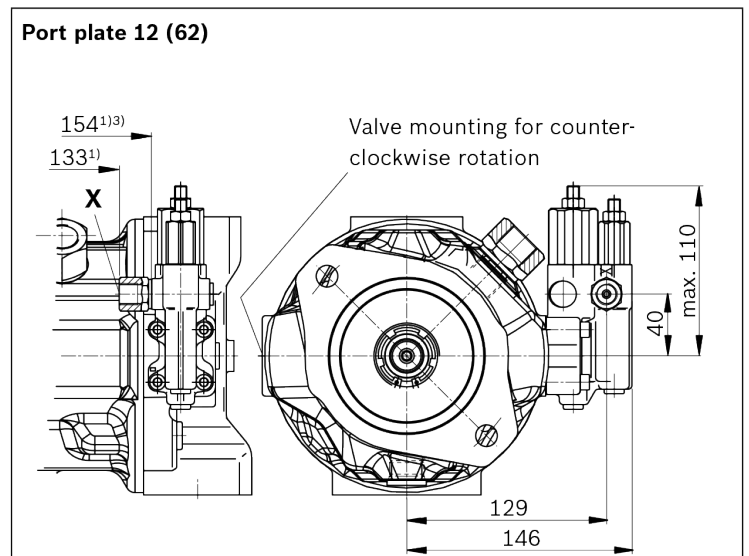

1) To flange surface

2) For version port plate 61

3) For version port plate 62

▼ DFLR – Pressure, flow and power controller

Port plate 11 (61)

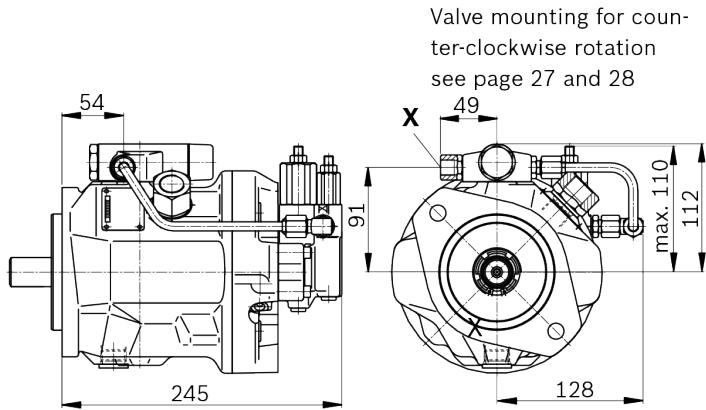

▼ DFLR – Pressure, flow and power controller

Port plate 12 (62)

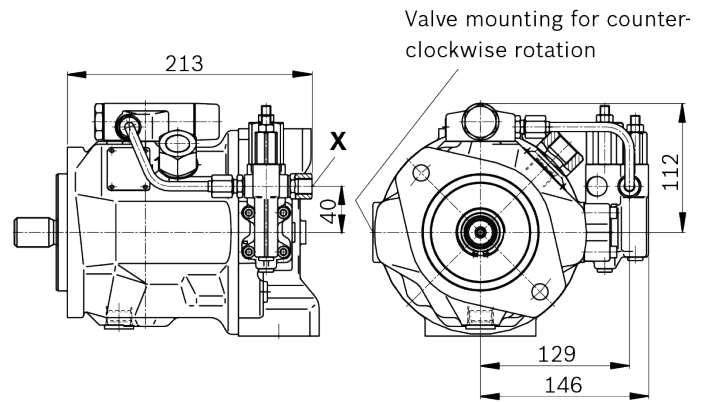

▼ ED7. / ER7. – Electro-hydraulic pressure control

Port plate 11 (61)

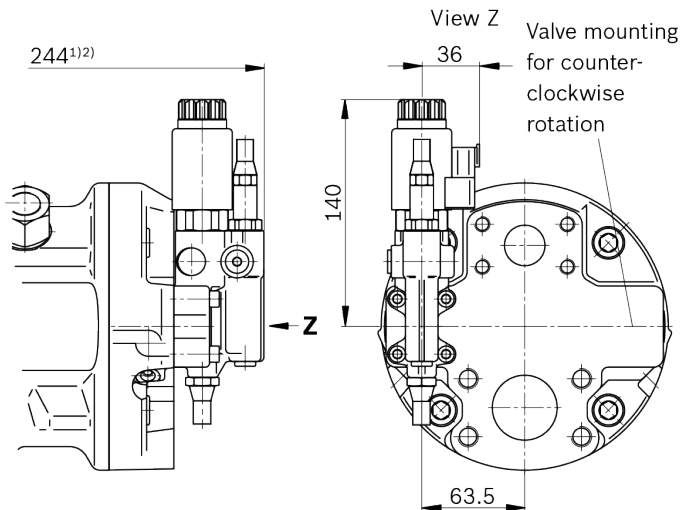

▼ ED7. / ER7. – Electro-hydraulic pressure control

Port plate 12 (62)

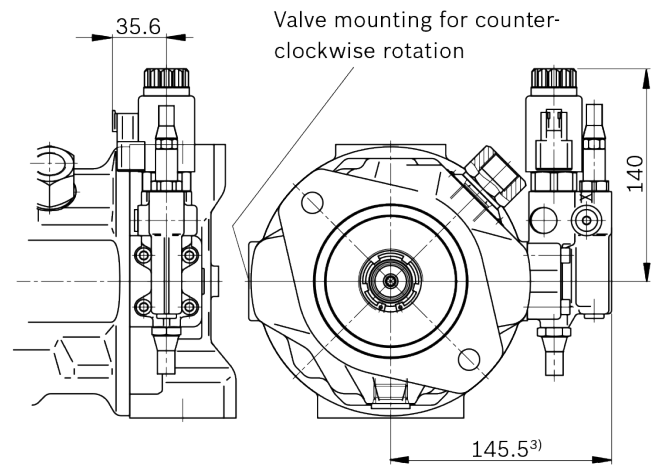

# Dimensions sizes 71 and 88

DFR / DFR1 / DRSC – Pressure and flow control, hydraulic; clockwise rotation, version: Ports metric

## ▼ Port plate 42

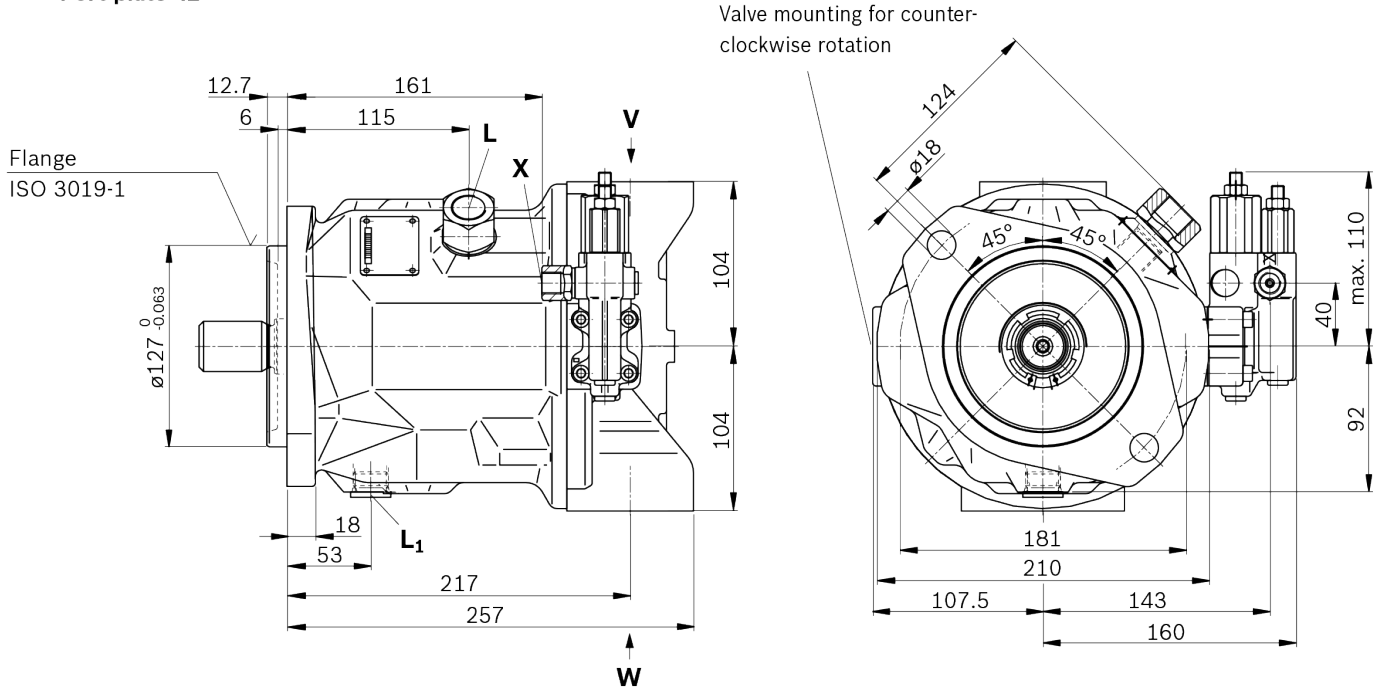

## ▼ Port plate 41

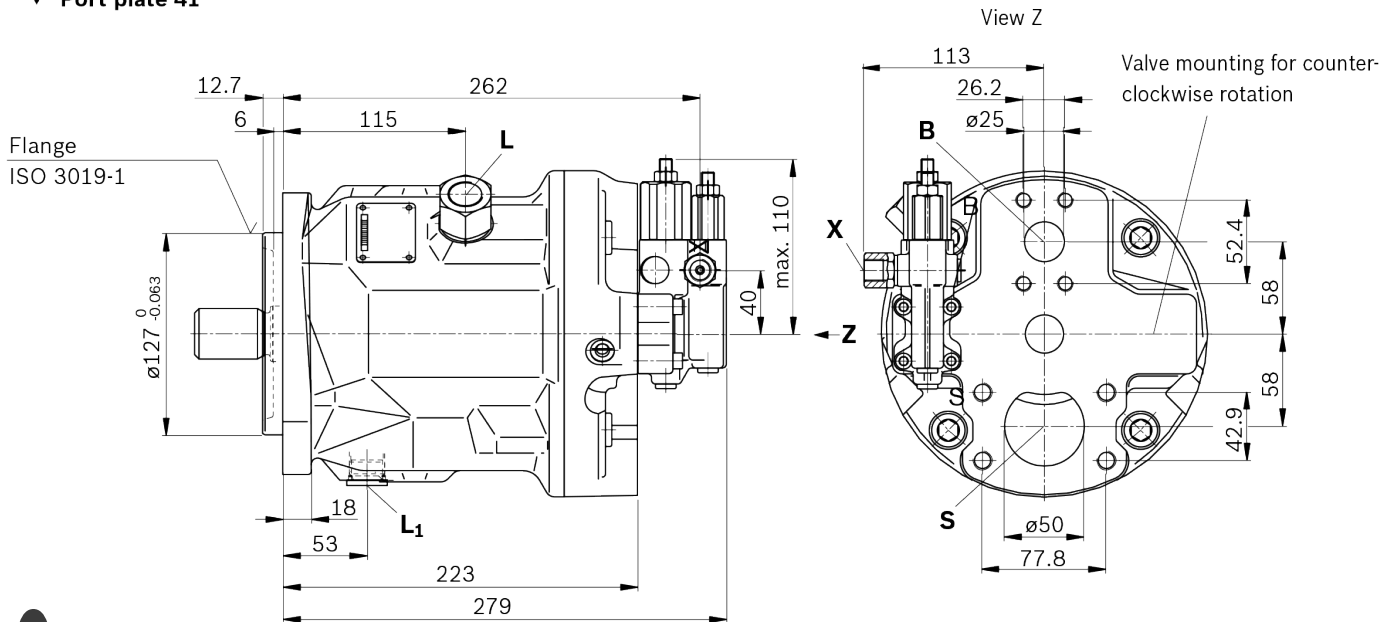

# Dimensions sizes 71 and 88

DFR / DFR1 / DRSC – Pressure and flow control, hydraulic; clockwise rotation, version: SAE ports

## ▼ Port plate 92

Valve mounting for counter-clockwise rotation

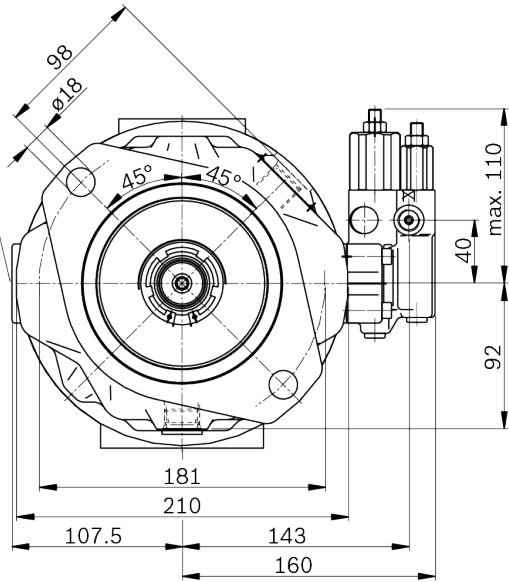
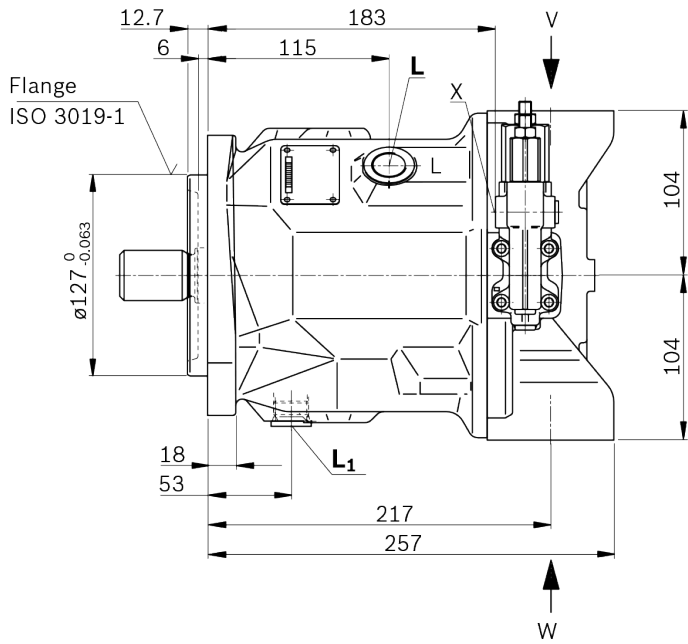

Detail V

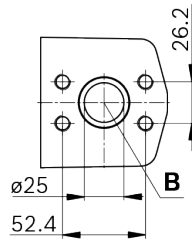

Detail W

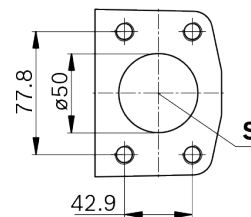

## ▼ Port plate 91

Valve mounting for counter-clockwise rotation

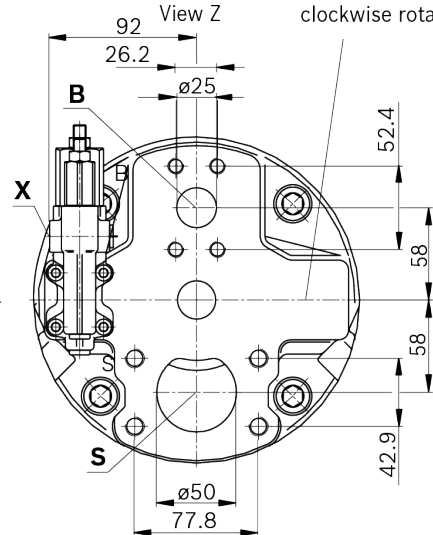
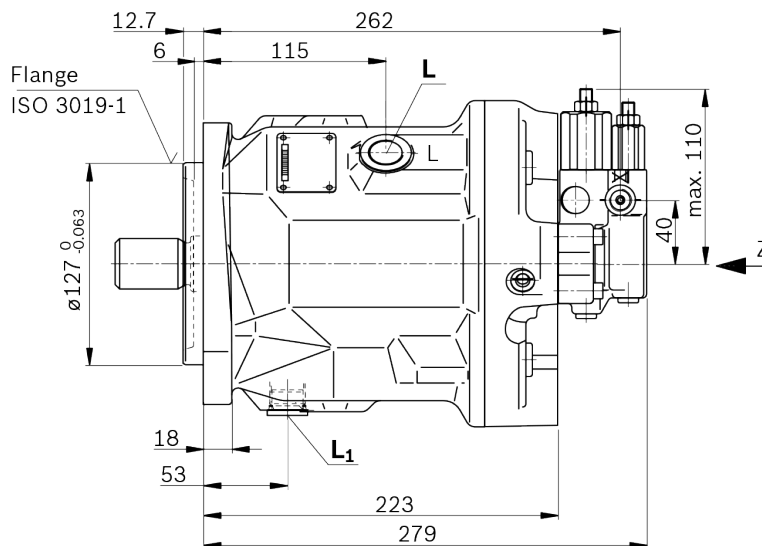

▼ Splined shaft 1 1/4 in (SAE J744)

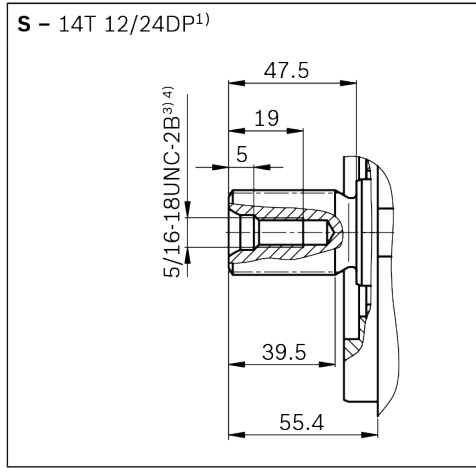

▼ Splined shaft 1 1/4 in (SAE J744)

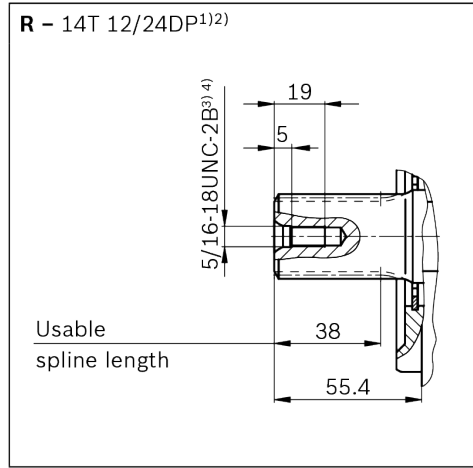

▼ Splined shaft 1 in (SAE J744)

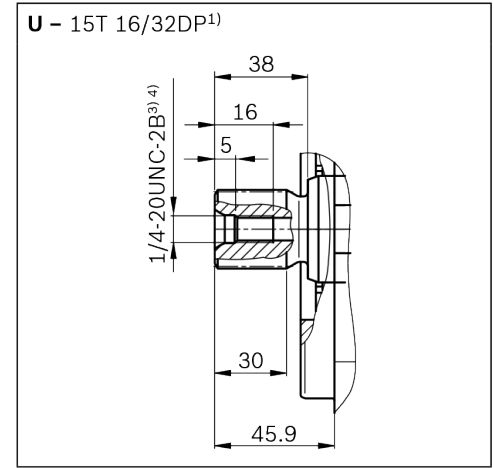

▼ Splined shaft 1 in (SAE J744)

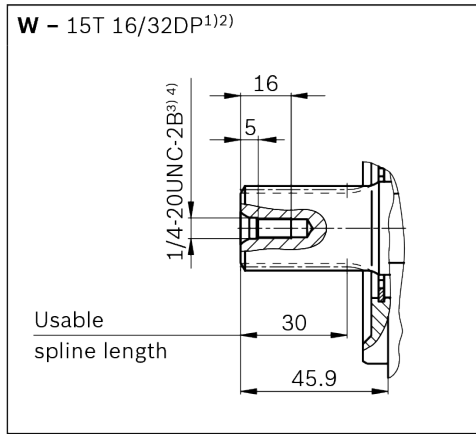

Ports - version metric port plate 41/42		Standard	Size <sup>4)</sup>	$p_{\max \text{ abs}}$ [bar] <sup>5)</sup>	State <sup>9)</sup>
<b>B</b>	Working port (standard pressure series) Fastening thread	SAE J518 <sup>6)</sup> DIN 13	1 in M10 × 1.5; 17 deep	350	O
<b>S</b>	Suction port (standard pressure series) Fastening thread	SAE J518 <sup>6)</sup> DIN 13	2 in M12 × 1.75; 20 deep	10	O
<b>L</b>	Drain port	DIN 3852 <sup>7)</sup>	M22 × 1.5; 14 deep	2	O <sup>8)</sup>
<b>L<sub>1</sub></b>	Drain port	ISO 11926 <sup>7)</sup>	7/8-14 UNF-2B; 16 deep	2	X <sup>8)</sup>
<b>X</b>	Pilot pressure	DIN 3852	M14 × 1.5; 12 deep	350	O
<b>X</b>	Pilot pressure with DG-control	DIN ISO 228	G1/4 in; 12 deep	350	O

  

Ports - version SAE port plate 91/92		Standard	Size <sup>4)</sup>	$p_{\max \text{ abs}}$ [bar] <sup>5)</sup>	State <sup>9)</sup>
<b>B</b>	Working port (standard pressure series) Fastening thread	SAE J518 ASME B1.1	1 in 3/8-16 UNC-2B; 18 deep	350	O
<b>S</b>	Suction port (standard pressure series) Fastening thread	SAE J518 ASME B1.1	2 in 1/2-13UNC-2B; 22 deep	10	O
<b>L</b>	Drain port	ISO 11926 <sup>7)</sup>	7/8-14 UNF-2B; 16 deep	2	O <sup>8)</sup>
<b>L<sub>1</sub></b>	Drain port	ISO 11926 <sup>7)</sup>	7/8-14 UNF-2B; 16 deep	2	X <sup>8)</sup>
<b>X</b>	Pilot pressure	ISO 11926	7/16-20 UNF-2B; 11.5 deep	350	O
<b>X</b>	Pilot pressure with DG-control	DIN ISO 228	G1/4 in; 12 deep	350	O

1) Involute spline according to ANSI B92.1a, 30° pressure angle, flat root, side fit, tolerance class 5  
 2) Splines according to ANSI B92.1a, run out of spline is a deviation from standard.  
 3) Thread according to ASME B1.1  
 4) For notes on tightening torques, see the instruction manual  
 5) Depending on the application, momentary pressure peaks can occur. Keep this in mind when selecting measuring devices and fittings.

6) Metric fastening thread is a deviation from standard.  
 7) The countersink can be deeper than as specified in the standard.  
 8) Depending on the installation position, L or L<sub>1</sub> must be connected (also see installation instructions starting on page 56).  
 9) O = Must be connected (plugged when delivered)  
 X = Plugged (in normal operation)

▼ DG – Two-point control, direct operated

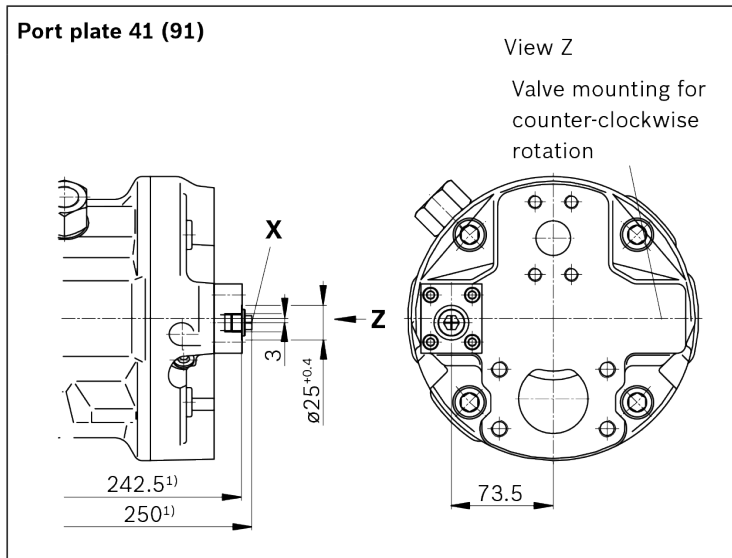

▼ DG – Two-point control, direct operated

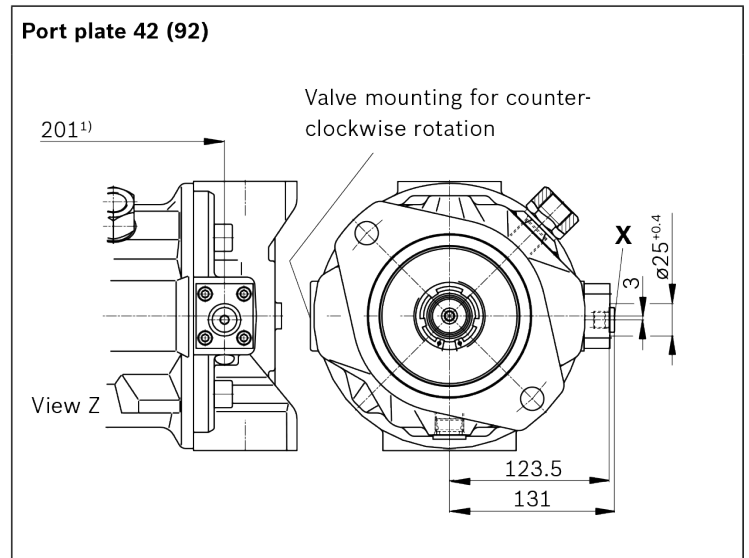

▼ DR – Pressure controller

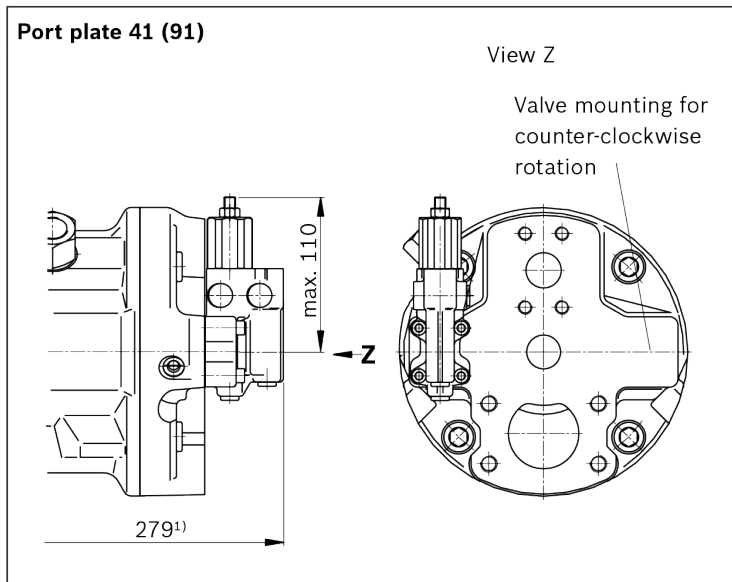

▼ DR – Pressure controller

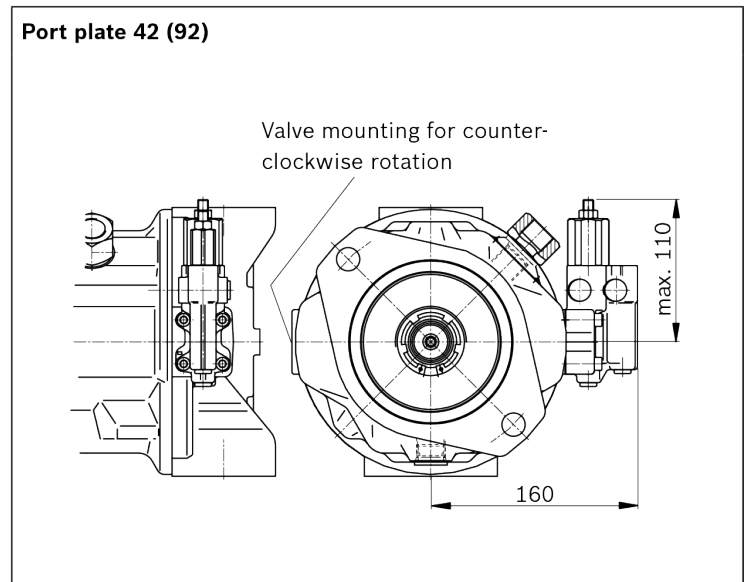

▼ DRG – Pressure controller, remote controlled

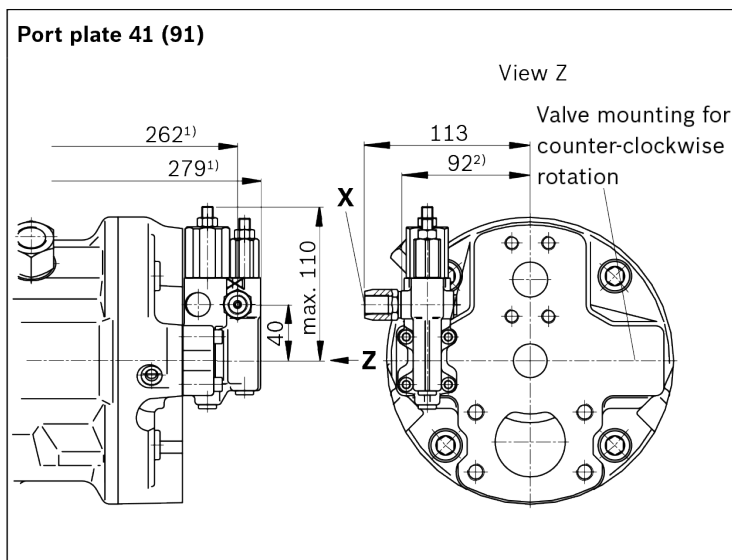

▼ DRG – Pressure controller, remote controlled

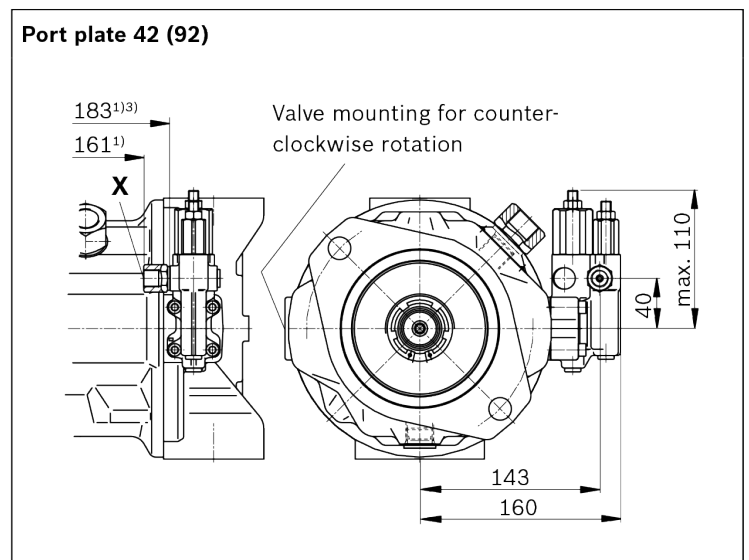

1) To flange surface

2) For version port plate 91

3) For version port plate 92

▼ DFLR – Pressure, flow and power controller

Port plate 41 (91)

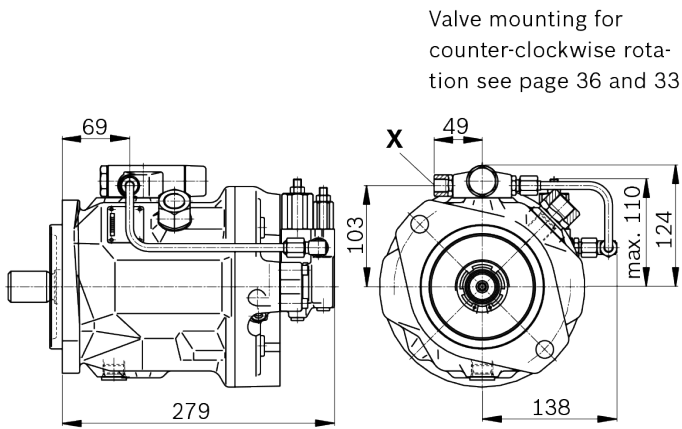

▼ DFLR – Pressure, flow and power controller

Port plate 42 (92)

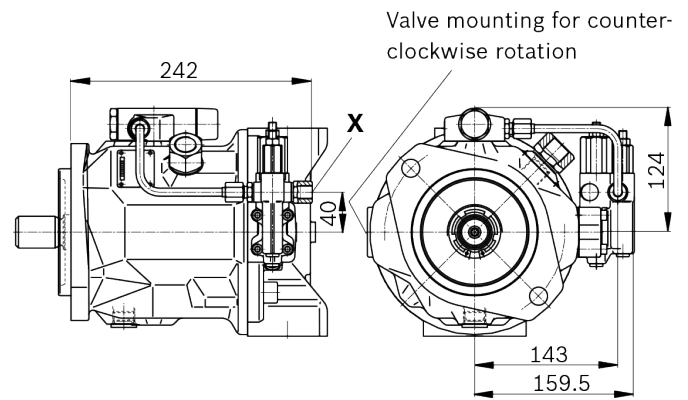

▼ ED7. / ER7. – Electro-hydraulic pressure control

Port plate 41 (91)

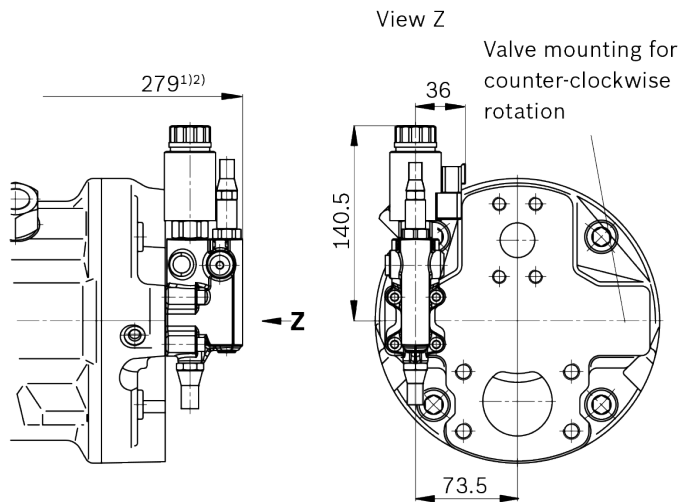

▼ ED7. / ER7. – Electro-hydraulic pressure control

Port plate 42 (92)

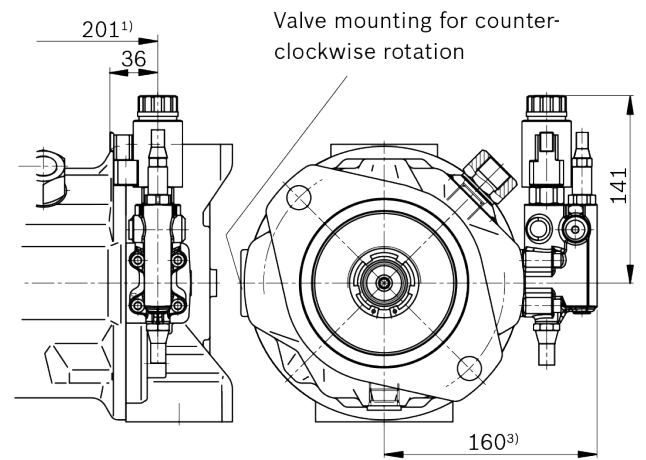

# Dimensions, size 100

DFR / DFR1 / DRSC – Pressure and flow control, hydraulic; clockwise rotation, version: Ports metric

## ▼ Port plate 12

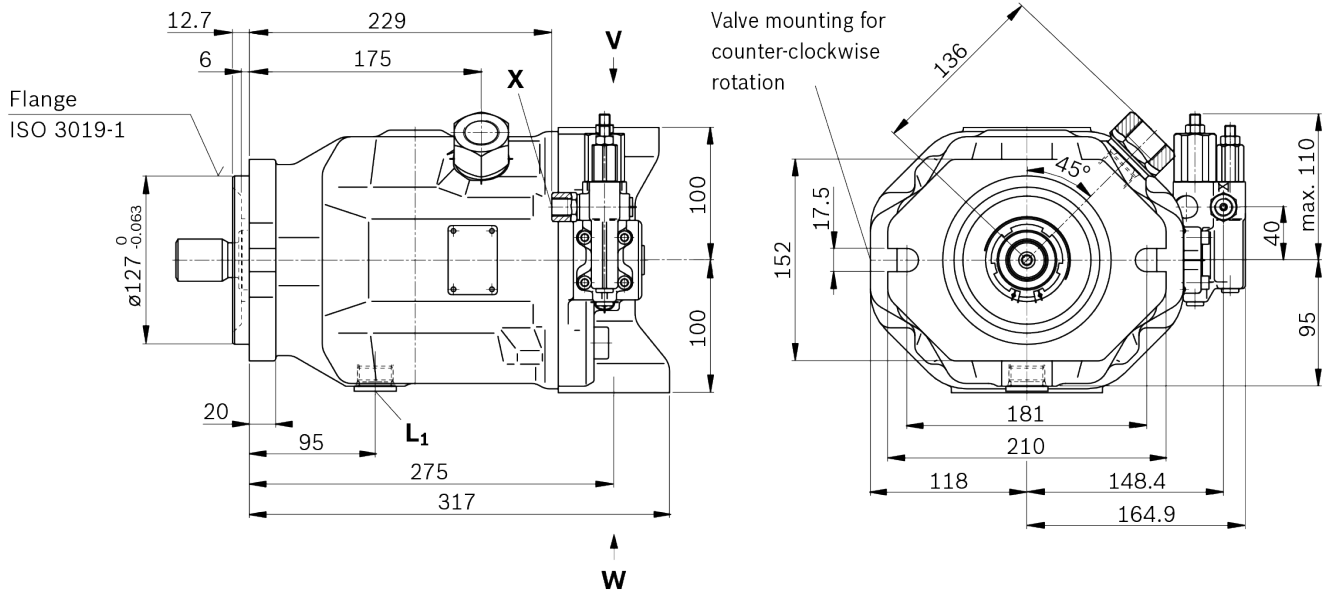

Detail V

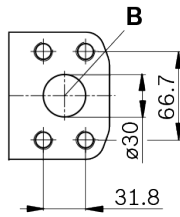

Detail W

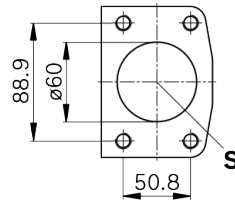

## ▼ Port plate 11

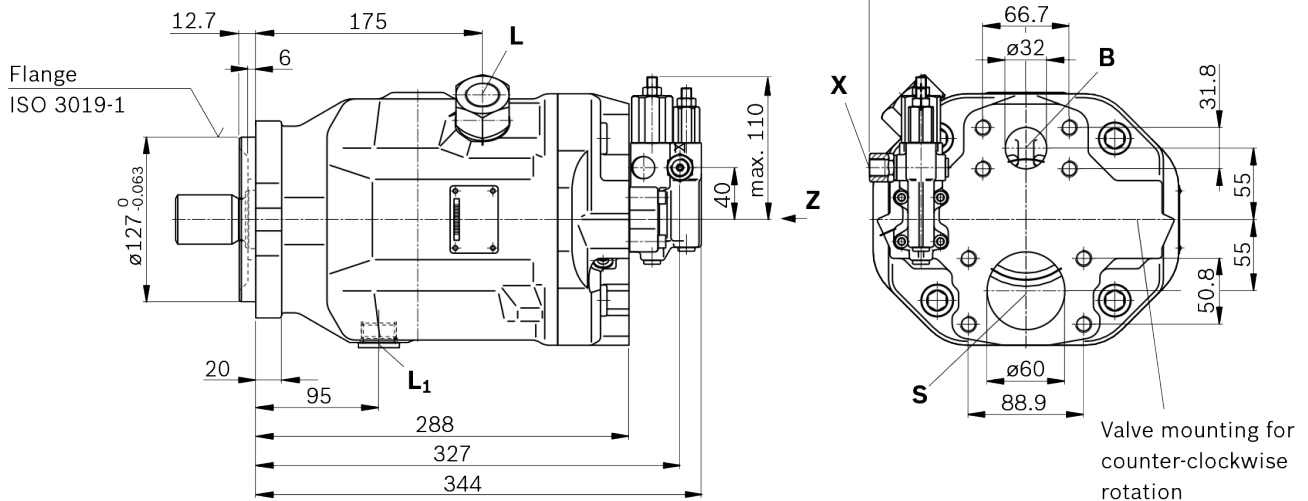

View Z

Valve mounting for counter-clockwise rotation



▼ Splined shaft 1 1/2 in (SAE J744)

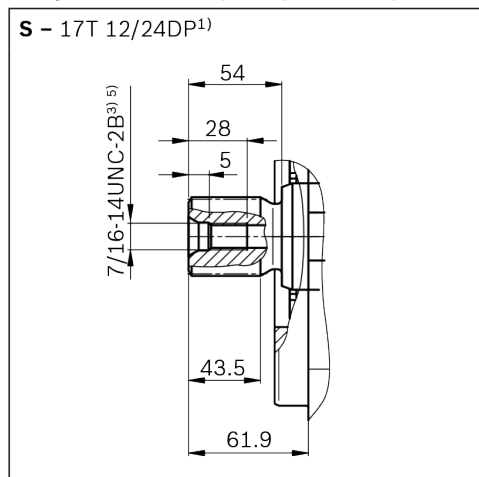

▼ Splined shaft 1 1/4 in (SAE J744)

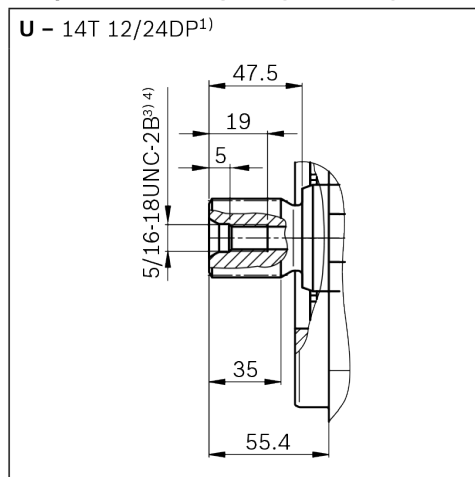

▼ Splined shaft 1 1/4 in (SAE J744)

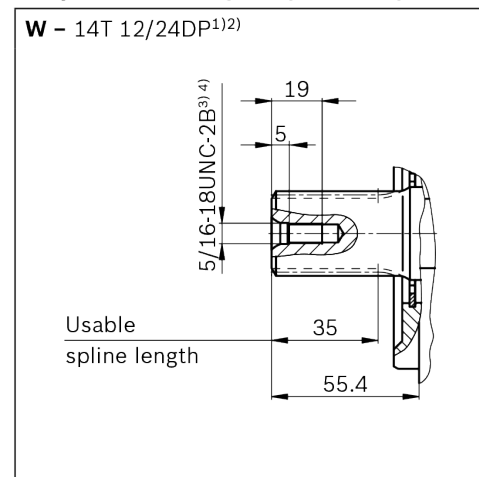

Ports - version metric port plate 11/12		Standard	Size <sup>4)</sup>	$p_{\max \text{ abs}}$ [bar] <sup>5)</sup>	State <sup>9)</sup>
<b>B</b>	Working port (high-pressure series) Fastening thread	SAE J518 <sup>6)</sup> DIN 13	1 1/4 in M14 × 2; 19 deep	350	O
<b>S</b>	Suction port (standard pressure series) Fastening thread	SAE J518 <sup>6)</sup> DIN 13	2 1/2 in M12 × 1.75; 17 deep	10	O
<b>L</b>	Drain port	DIN 3852 <sup>7)</sup>	M27 × 2; 16 deep	2	O <sup>8)</sup>
<b>L<sub>1</sub></b>	Drain port	ISO 11926 <sup>7)</sup>	1 1/16-12 UNF-2B; 18 deep	2	X <sup>8)</sup>
<b>X</b>	Pilot pressure	DIN 3852	M14 × 1.5; 12 deep	350	O
<b>X</b>	Pilot pressure with DG-control	DIN ISO 228	G1/4 in; 12 deep	350	O
Ports - version SAE port plate 61/62		Standard	Size <sup>4)</sup>	$p_{\max \text{ abs}}$ [bar] <sup>5)</sup>	State <sup>9)</sup>
<b>B</b>	Working port (high-pressure series) Fastening thread	SAE J518 ASME B1.1	1 1/4 in 1/2-13 UNC-2B; 19 deep	350	O
<b>S</b>	Suction port (standard pressure series) Fastening thread	SAE J518 ASME B1.1	2 1/2 in 1/2-13 UNC-2B; 22 deep	10	O
<b>L</b>	Drain port	ISO 11926 <sup>7)</sup>	1 1/16-12 UNF-2B; 18 deep	2	O <sup>8)</sup>
<b>L<sub>1</sub></b>	Drain port	ISO 11926 <sup>7)</sup>	1 1/16-12 UNF-2B; 18 deep	2	X <sup>8)</sup>
<b>X</b>	Pilot pressure	ISO 11926	7/16-20 UNF-2B; 11.5 deep	350	O
<b>X</b>	Pilot pressure with DG-control	DIN ISO 228	G1/4 in; 12 deep	350	O

1) Involute spline according to ANSI B92.1a, 30° pressure angle, flat root, side fit, tolerance class 5  
 2) Splines according to ANSI B92.1a, run out of spline is a deviation from standard.  
 3) Thread according to ASME B1.1  
 4) For notes on tightening torques, see the instruction manual  
 5) Depending on the application, momentary pressure peaks can occur. Keep this in mind when selecting measuring devices and fittings.

6) Metric fastening thread is a deviation from standard.  
 7) The countersink can be deeper than as specified in the standard.  
 8) Depending on the installation position, L or L<sub>1</sub> must be connected (also see installation instructions starting on page 56).  
 9) O = Must be connected (plugged when delivered)  
 X = Plugged (in normal operation)

▼ DG – Two-point control, direct operated

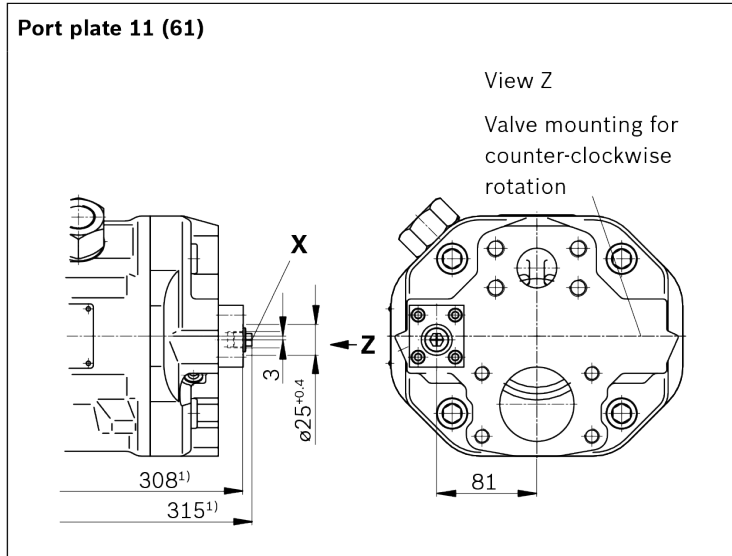

▼ DG – Two-point control, direct operated

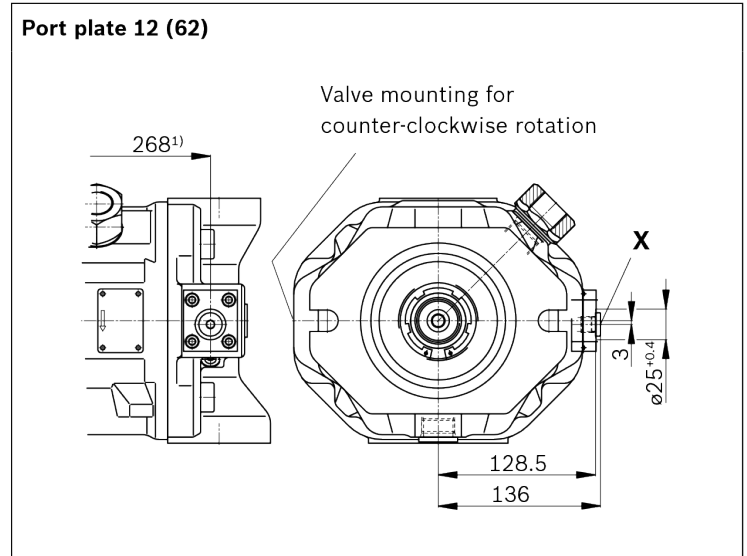

▼ DR – Pressure controller

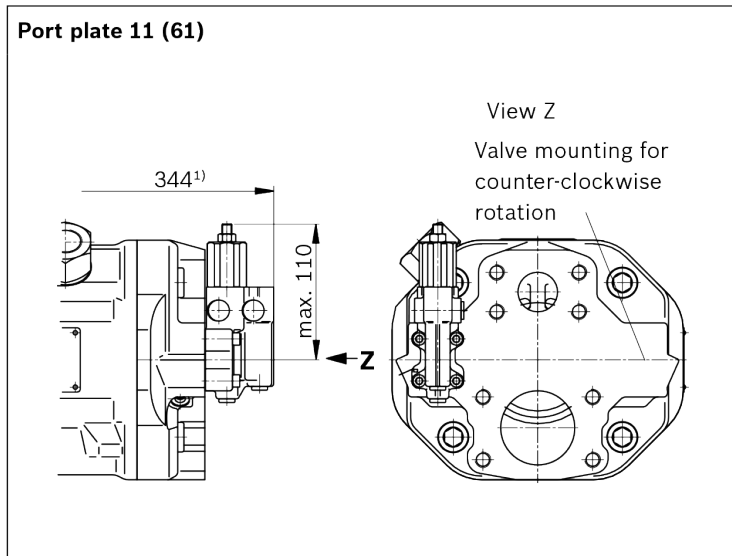

▼ DR – Pressure controller

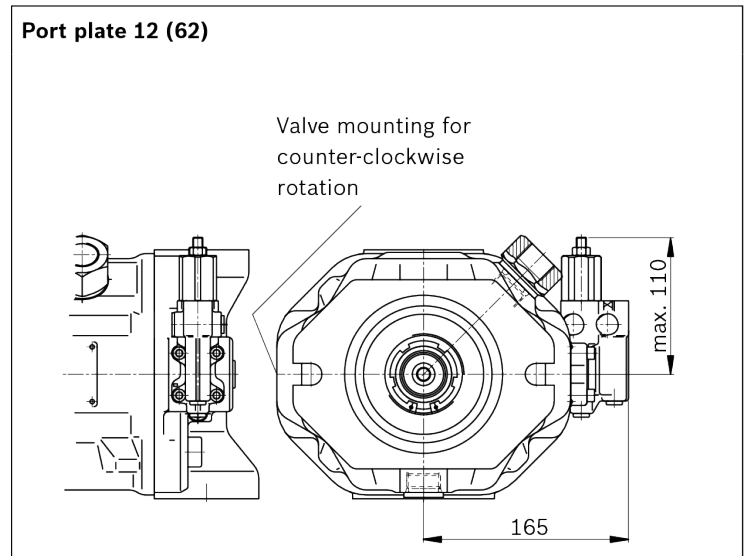

▼ DRG – Pressure controller, remote controlled

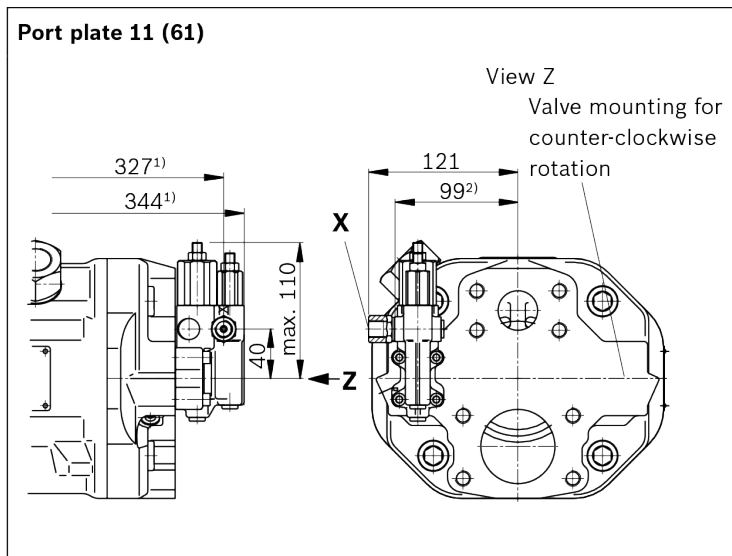

▼ DRG – Pressure controller, remote controlled

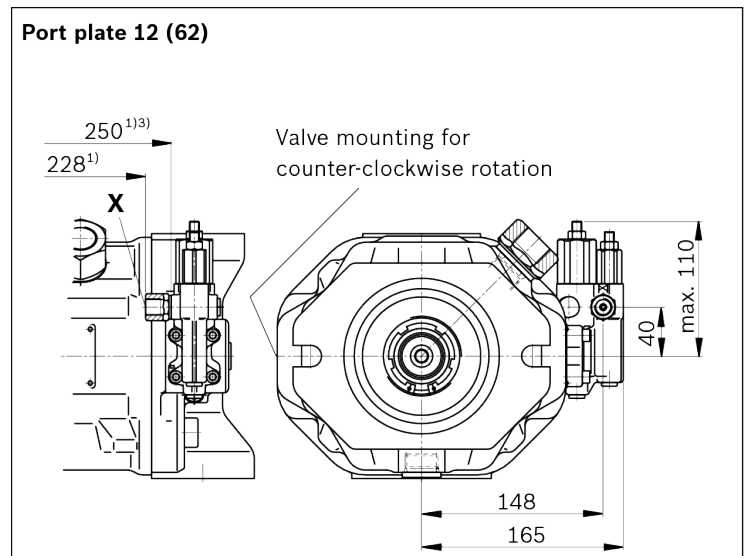

1) To flange surface  
2) For version port plate 61

3) For version port plate 62

▼ DFLR – Pressure, flow and power controller

Port plate 11 (61)

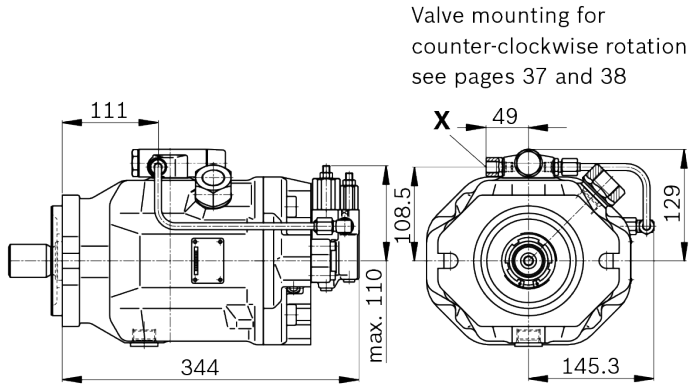

▼ DFLR – Pressure, flow and power controller

Port plate 12 (62)

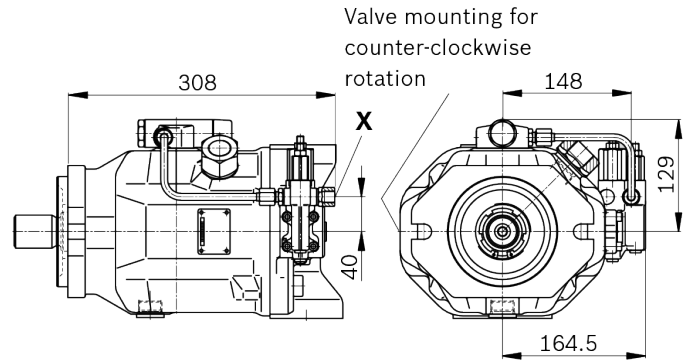

▼ ED7. / ER7. – Electro-hydraulic pressure control

Port plate 11 (61)

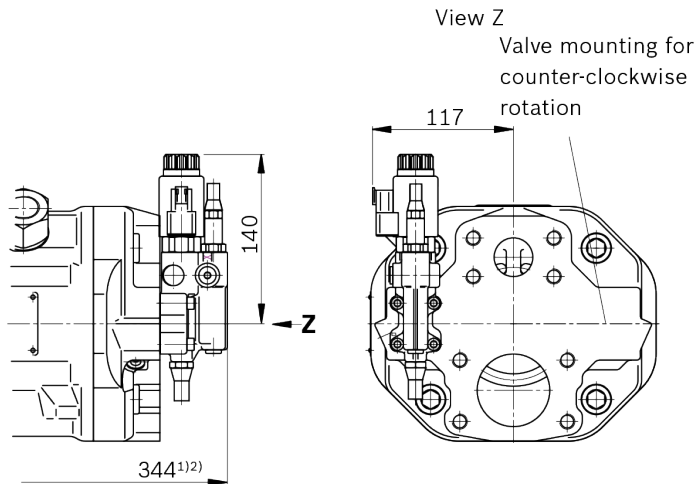

▼ ED7. / ER7. – Electro-hydraulic pressure control

Port plate 12 (62)

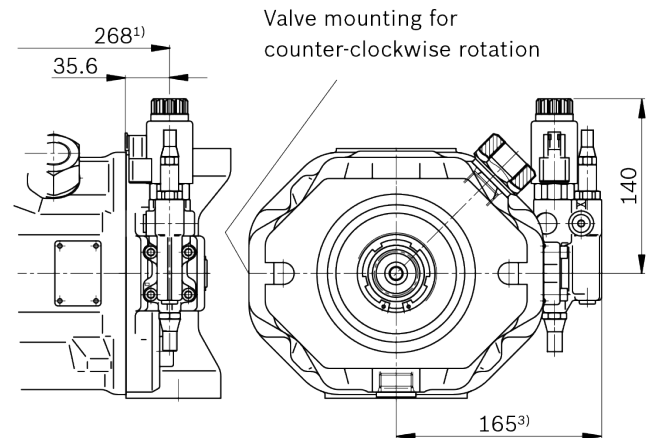

# Dimensions, size 140

DFR / DFR1 / DRSC – Pressure and flow control, hydraulic, clockwise rotation, mounting flange D, version metric

## ▼ Port plate 12

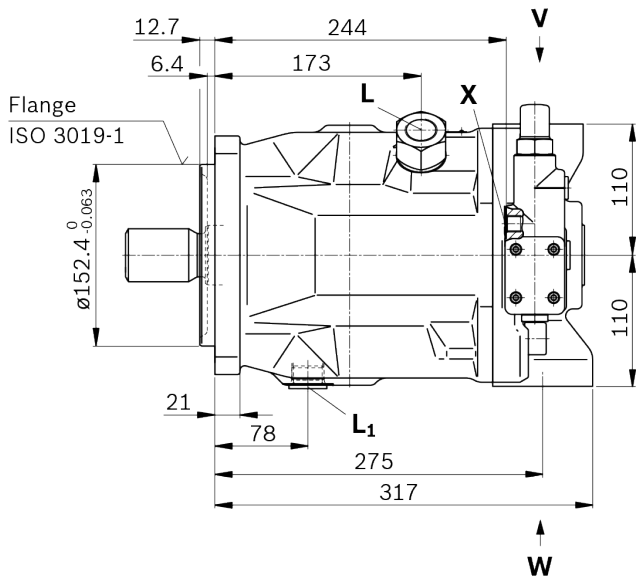

Detail V

Detail W

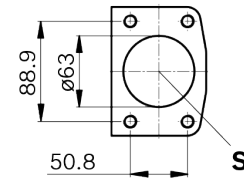
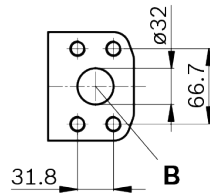

View Z

## ▼ Port plate 11

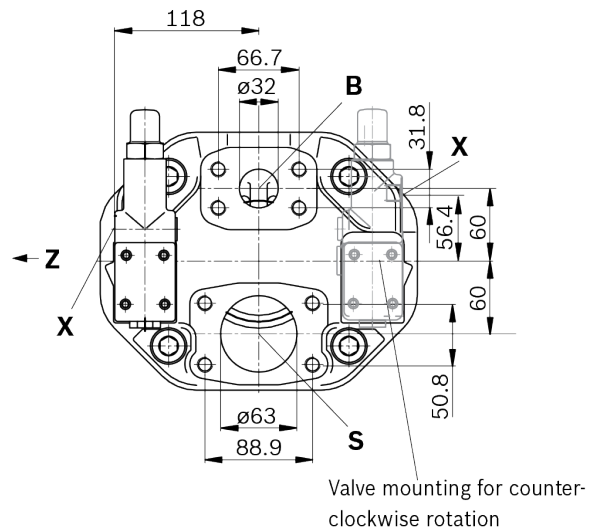
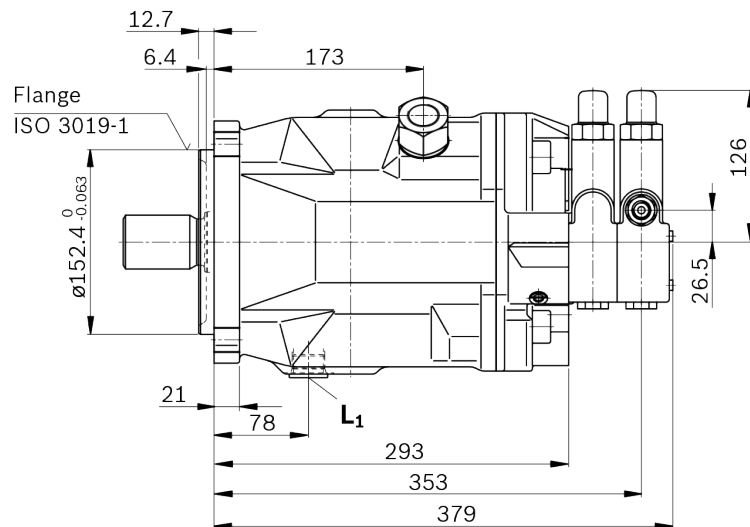

▼ Port plate 62

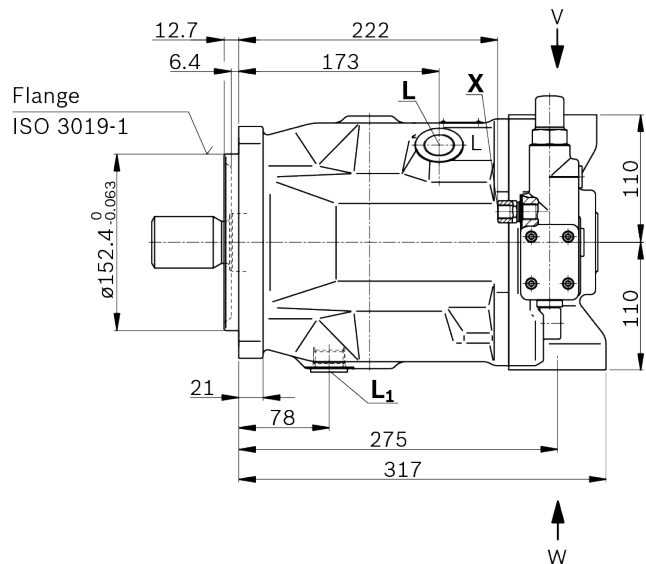

Detail V

Valve mounting for counter-clockwise rotation

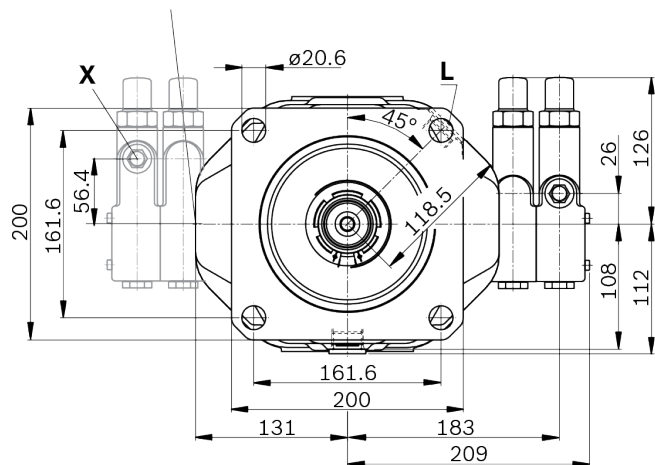

Detail W

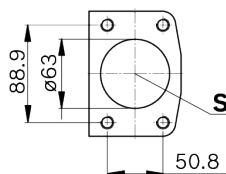
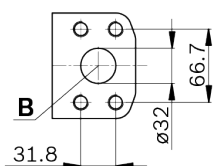

▼ Port plate 61

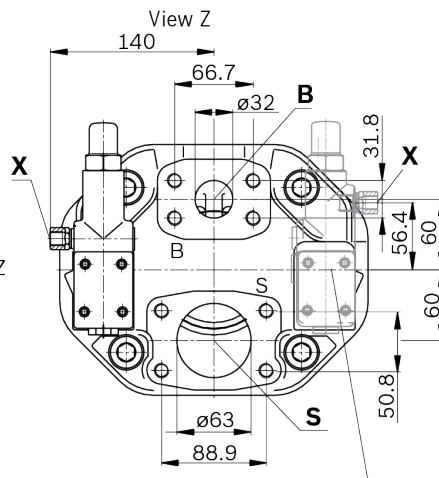
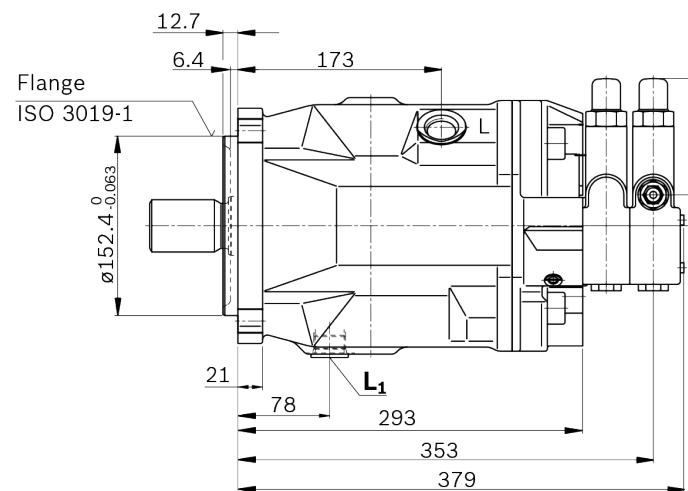

Valve mounting for counter-clockwise rotation

▼ Port plate 12

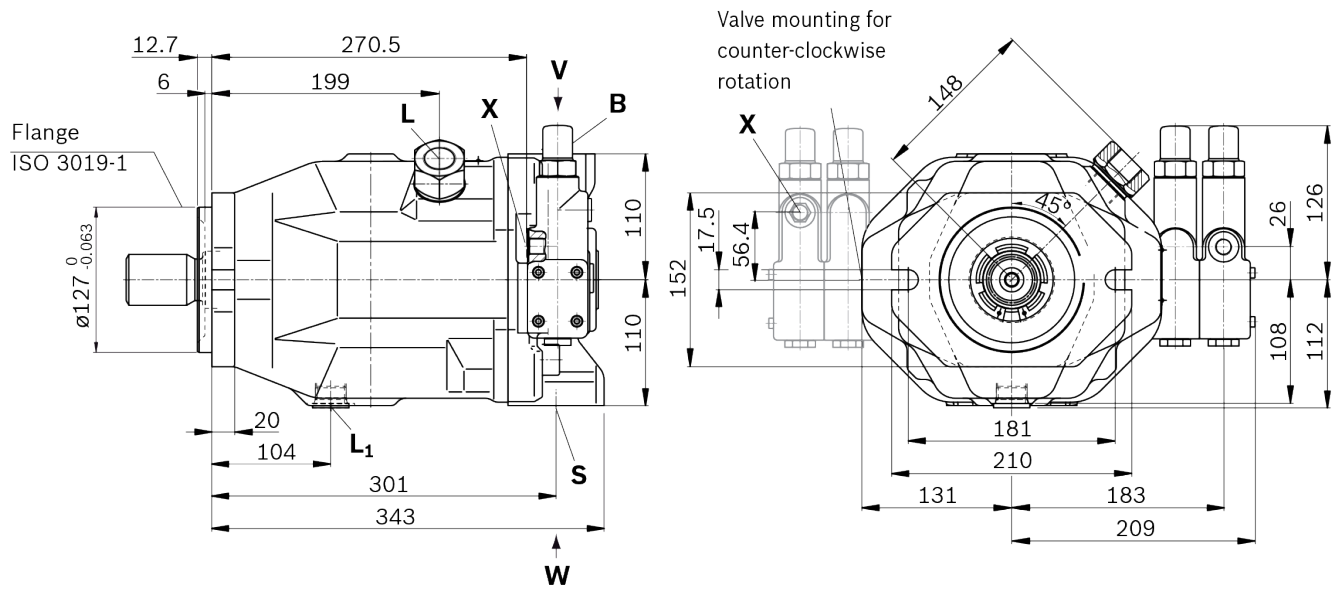

Detail V

Detail W

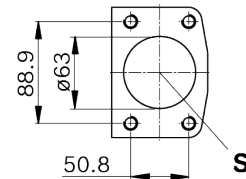
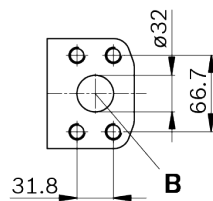

View Z

▼ Port plate 11

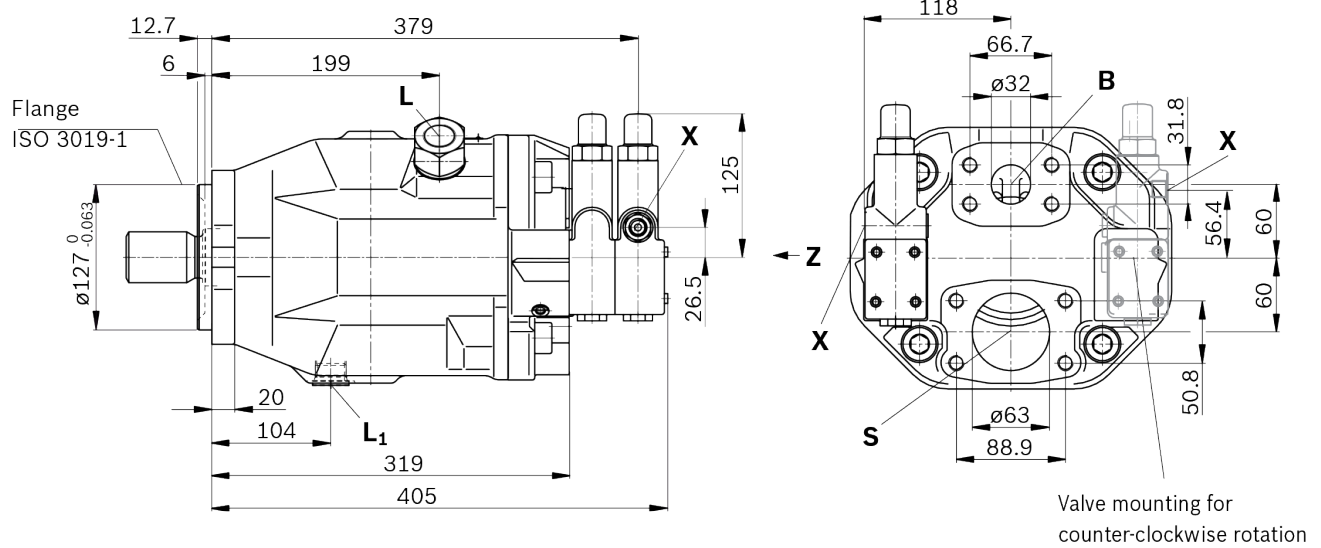

▼ Port plate 62

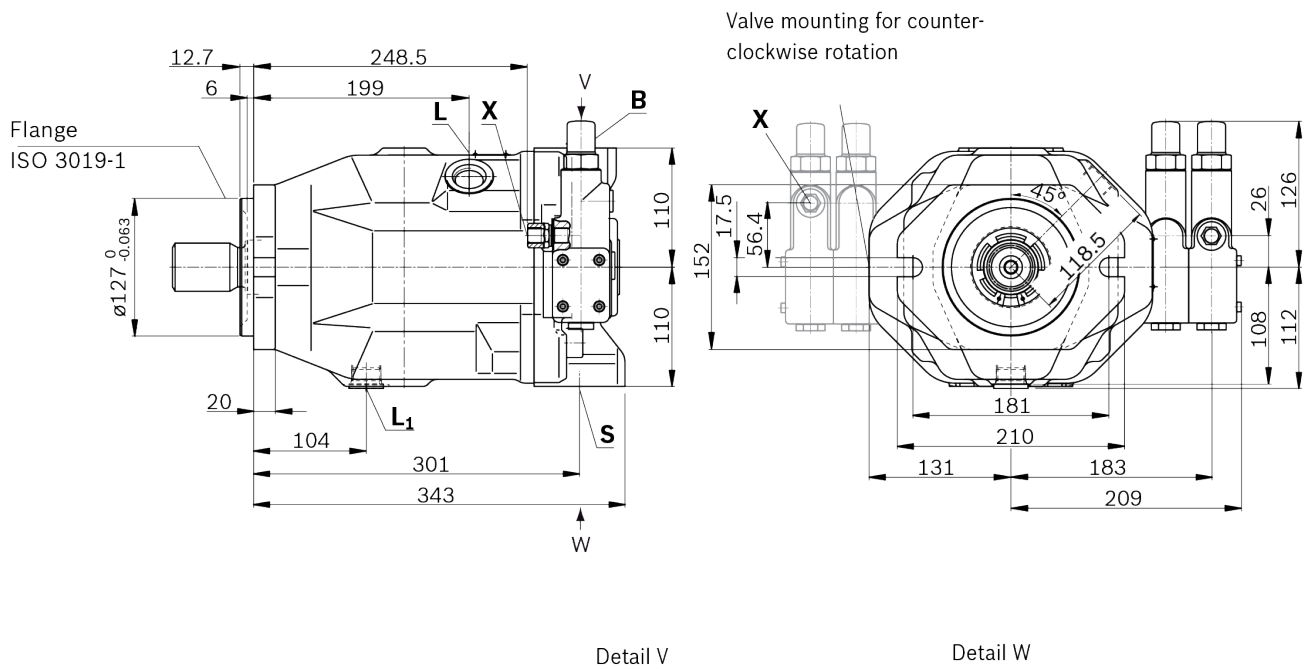

▼ Port plate 61

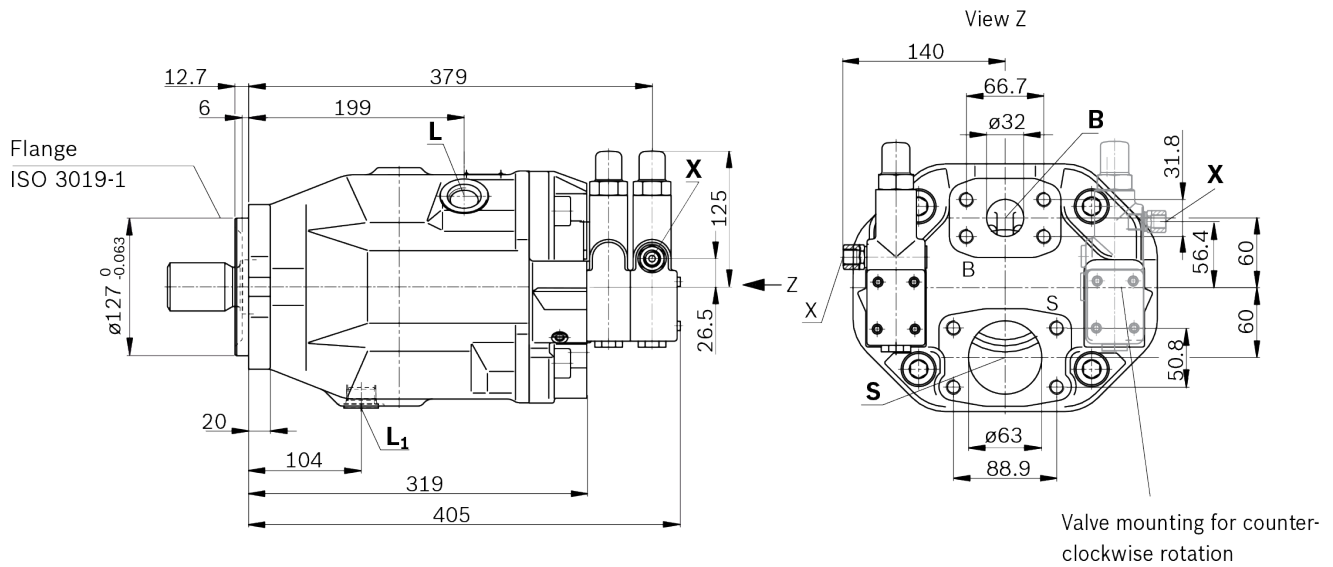

▼ Splined shaft 1 3/4 in (SAE J744)

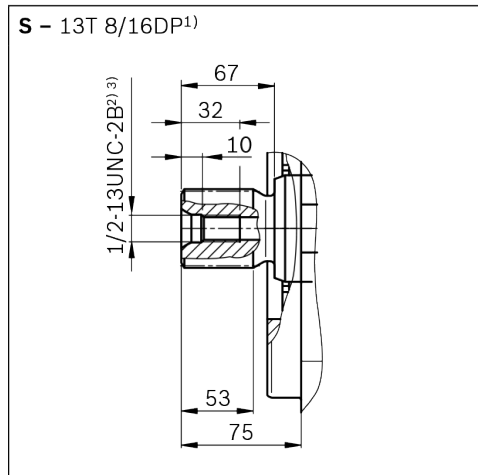

▼ Splined shaft 1 1/2 in (SAE J744)

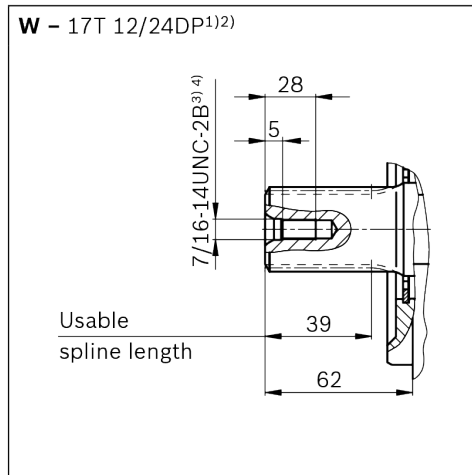

Ports - version metric port plate 11/12		Standard	Size <sup>3)</sup>	$p_{\max \text{ abs}}$ [bar] <sup>4)</sup>	State <sup>8)</sup>
<b>B</b>	Working port (high-pressure series) Fastening thread	SAE J518 <sup>5)</sup> DIN 13	1 1/4 in M14 × 2; 19 deep	350	O
<b>S</b>	Suction port (standard pressure series) Fastening thread	SAE J518 <sup>5)</sup> DIN 13	2 1/2 in M12 × 1.75; 17 deep	10	O
<b>L</b>	Drain port	DIN 3852 <sup>6)</sup>	M27 × 2; 16 deep	2	O <sup>7)</sup>
<b>L<sub>1</sub></b>	Drain port	ISO 11926 <sup>6)</sup>	1 1/16-12 UNF-2B; 18 deep	2	X <sup>7)</sup>
<b>X</b>	Pilot pressure	DIN 3852 <sup>6)</sup>	M14 × 1.5; 12 deep	350	O
<b>X</b>	Pilot pressure with DG-control	DIN 3852	M14 × 1.5; 12 deep	350	O
<b>M<sub>H</sub></b>	High pressure measurement (only with control DG)	DIN 3852	M14 × 1.5; 12 deep	350	X

Ports - version SAE port plate 61/62		Standard	Size <sup>3)</sup>	$p_{\max \text{ abs}}$ [bar] <sup>4)</sup>	State <sup>8)</sup>
<b>B</b>	Working port (high-pressure series) Fastening thread	SAE J518 ASME B1.1	1 1/4 in 1/2-13 UNC-2B; 24 deep	350	O
<b>S</b>	Suction port (standard pressure series) Fastening thread	SAE J518 ASME B1.1	2 1/2 in 1/2-13 UNC-2B; 24 deep	10	O
<b>L</b>	Drain port	ISO 11926 <sup>6)</sup>	1 1/16-12 UNF-2B; 18 deep	2	O <sup>7)</sup>
<b>L<sub>1</sub></b>	Drain port	ISO 11926 <sup>6)</sup>	1 1/16-12 UNF-2B; 18 deep	2	X <sup>7)</sup>
<b>X</b>	Pilot pressure	ISO 11926	9/16-18 UNF-2B; 13 deep	350	O
<b>X</b>	Pilot pressure with DG-control	DIN 3852	M14 × 1.5; 12 deep	350	O
<b>M<sub>H</sub></b>	High pressure measurement (only with control DG)	DIN 3852	M14 × 1.5; 12 deep	350	X

- 1) Involute spline according to ANSI B92.1a, 30° pressure angle, flat root, side fit, tolerance class 5
- 2) Thread according to ASME B1.1
- 3) For notes on tightening torques, see the instruction manual
- 4) Depending on the application, momentary pressure peaks can occur. Keep this in mind when selecting measuring devices and fittings.

- 5) Metric fastening thread is a deviation from standard.
- 6) The countersink can be deeper than as specified in the standard.
- 7) Depending on the installation position, L or L<sub>1</sub> must be connected (also see installation instructions starting on page 56).
- 8) O = Must be connected (plugged when delivered)  
X = Plugged (in normal operation)

▼ DG – Two-point control, direct operated

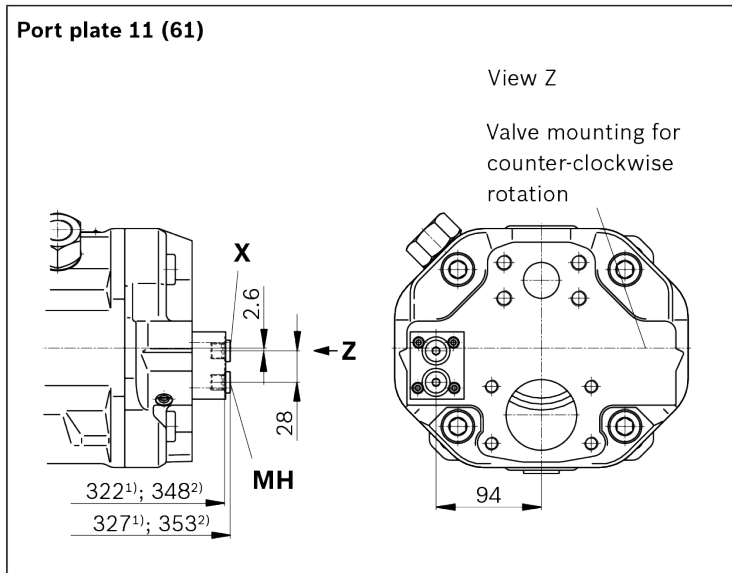

▼ DG – Two-point control, direct operated

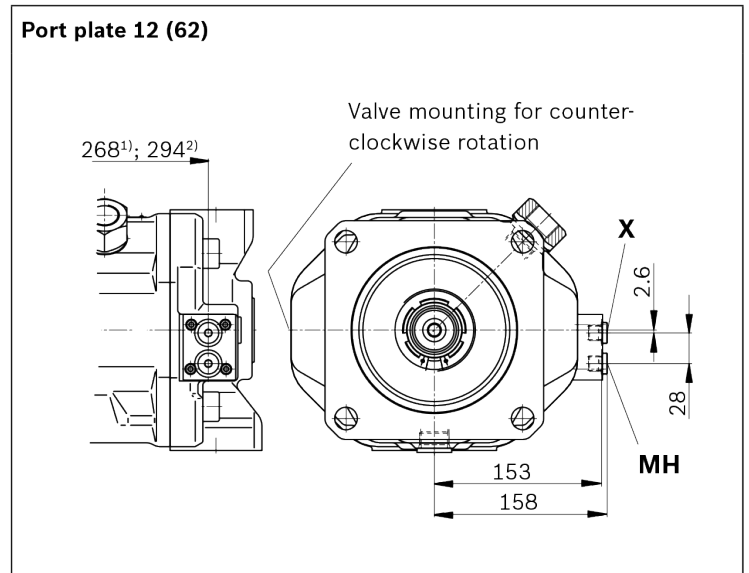

▼ DR – Pressure controller

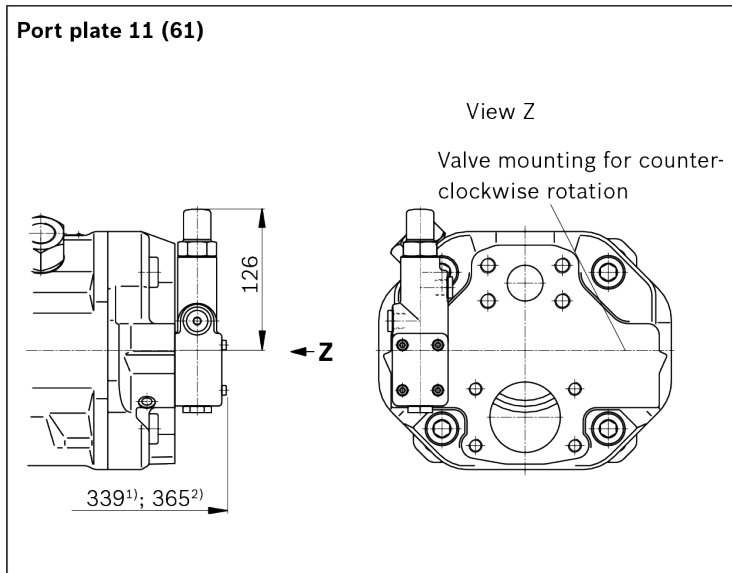

▼ DR – Pressure controller

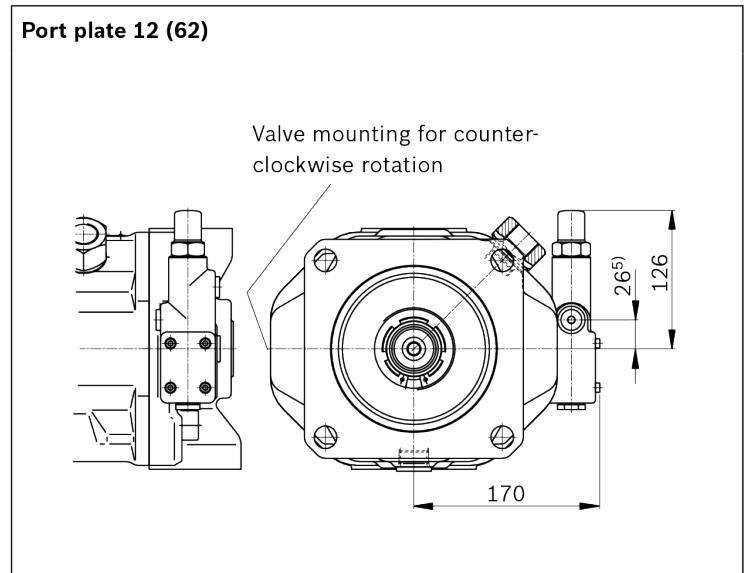

▼ DRG – Pressure controller, remote controlled

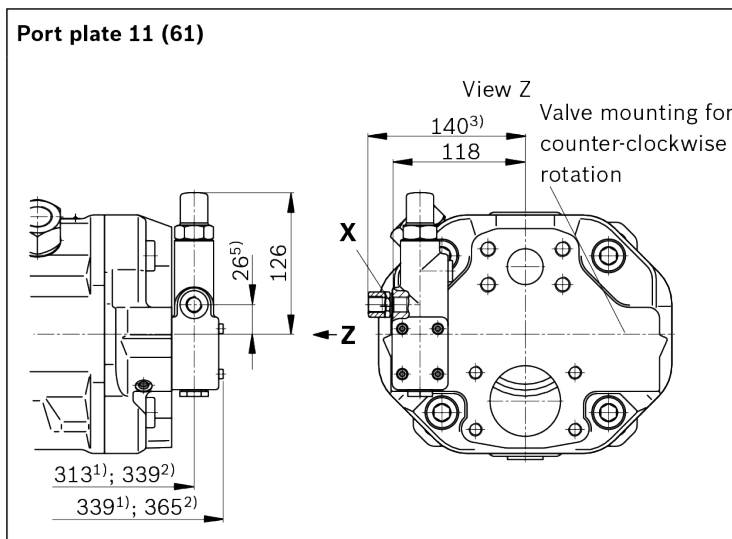

▼ DRG – Pressure controller, remote controlled

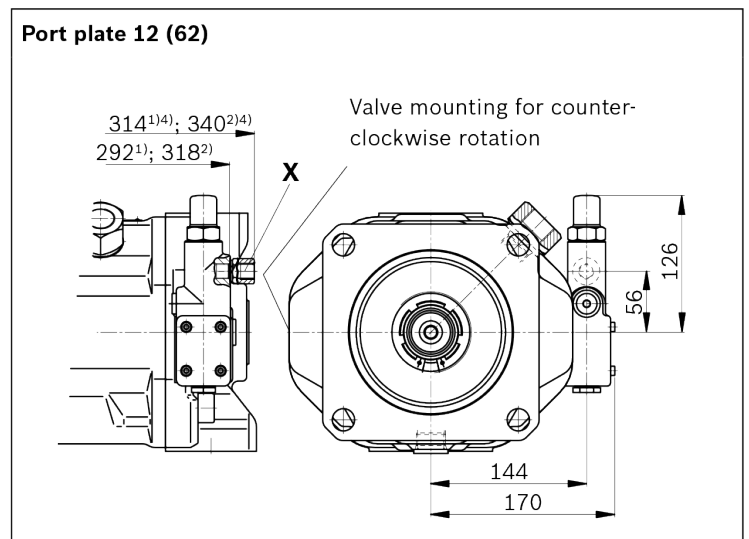

- 1) To flange surface and housing with D flange
- 2) To flange surface and housing with C flange
- 3) For version port plate 61

- 4) For version port plate 62
- 5) 56 mm with counter-clockwise rotation

▼ DFLR – Pressure, flow and power controller

Port plate 11 (61)

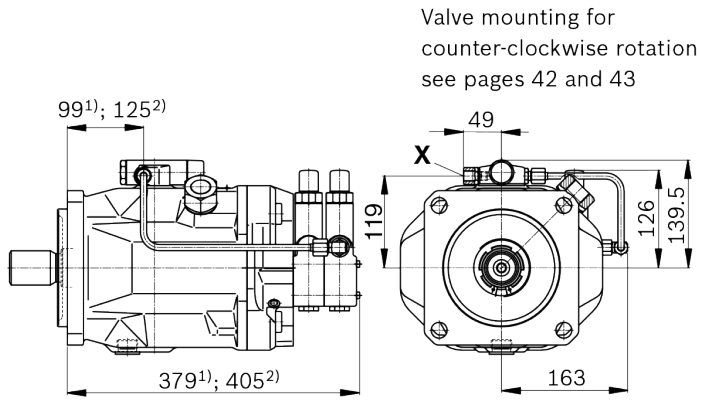

▼ DFLR – Pressure, flow and power controller

Port plate 12 (62)

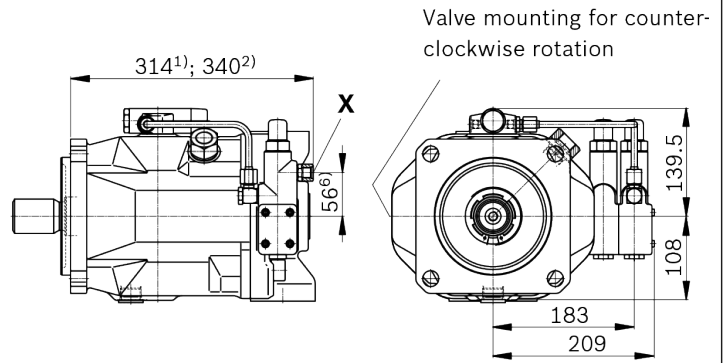

▼ ED7. / ER7. – Electro-hydraulic pressure control

Port plate 11 (61)

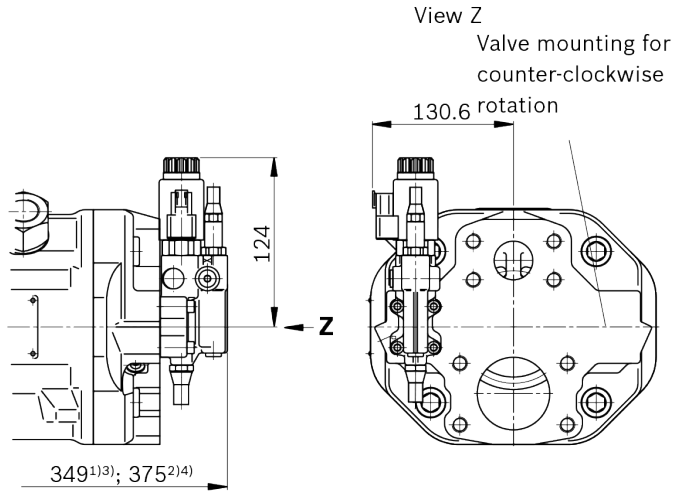

▼ ED7. / ER7. – Electro-hydraulic pressure control

Port plate 12 (62)

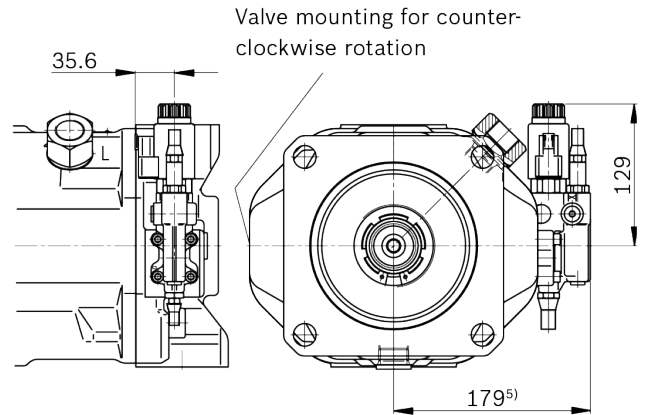

## Dimensions, through drive

Flange ISO 3019-1 (SAE)		Hub for splined shaft <sup>1)</sup>		Availability over sizes							Code
Diameter	Symbol	Diameter		18	28	45	71	88	100	140	
82-2 (A)	⌀, ⌀ <sup>2</sup> , ∞	5/8 in	9T 16/32DP	•	•	•	•	•	•	•	K01
		3/4 in	11T 16/32DP	•	•	•	•	•	•	•	K52

• = Available    - = Not available

### ▼ 82-2

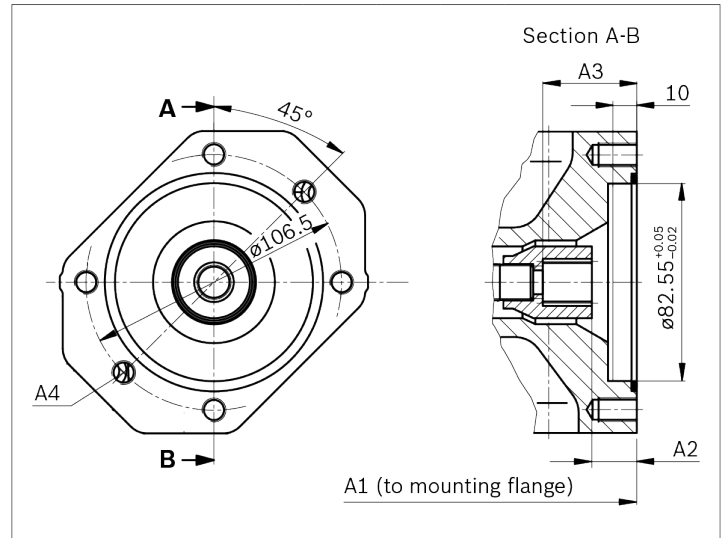
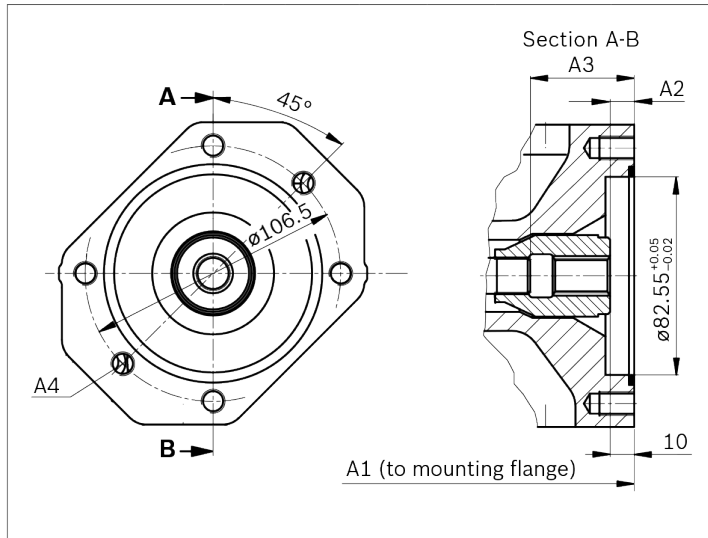

K01	NG	A1	A2	A3	A4 <sup>2)</sup>
(SAE J744 16-4 (A))					
	18	182	10	43.3	M10×1.5; 14.5 deep
	28	204	10	33.7	M10×1.5; 16 deep
	45	229	10.7	53.4	M10×1.5; 16 deep
	71	267	11.8	61.3	M10×1.5; 20 deep
	88	267	11.8	61.3	M10×1.5; 20 deep
	100	338	10.5	65	M10×1.5; 16 deep
	140	350 <sup>3)</sup> 376 <sup>4)</sup>	10.8	77.3	M10×1.5; 16 deep

K52	NG	A1	A2	A3	A4 <sup>2)</sup>
(SAE J744 19-4 (A-B))					
	18	182	18.8	38.7	M10×1.5; 14.5 deep
	28	204	18.8	38.7	M10×1.5; 16 deep
	45	229	18.9	38.7	M10×1.5; 16 deep
	71	267	21.3	41.4	M10×1.5; 20 deep
	88	267	21.3	41.4	M10×1.5; 20 deep
	100	338	19	38.9	M10×1.5; 16 deep
	140	350 <sup>3)</sup> 376 <sup>4)</sup>	18.9	38.6	M10×1.5; 16 deep

- 1) According to ANSI B92.1a, 30° pressure angle, flat root, side fit, tolerance class 5
- 2) Thread according to DIN 13, see instruction manual for maximum tightening torques.

- 3) Housing with D flange
- 4) Housing with C flange

Flange ISO 3019-1 (SAE)		Hub for splined shaft <sup>1)</sup>		Availability over sizes							Code
Diameter	Symbol	Diameter		18	28	45	71	88	100	140	
101-2 (B)	⌀, ⌀, ∞	7/8 in	13T 16/32DP	-	•	•	•	•	•	•	K68
		1 in	15T 16/32DP	-	-	•	•	•	•	•	K04

• = Available    - = Not available

▼ 101-2

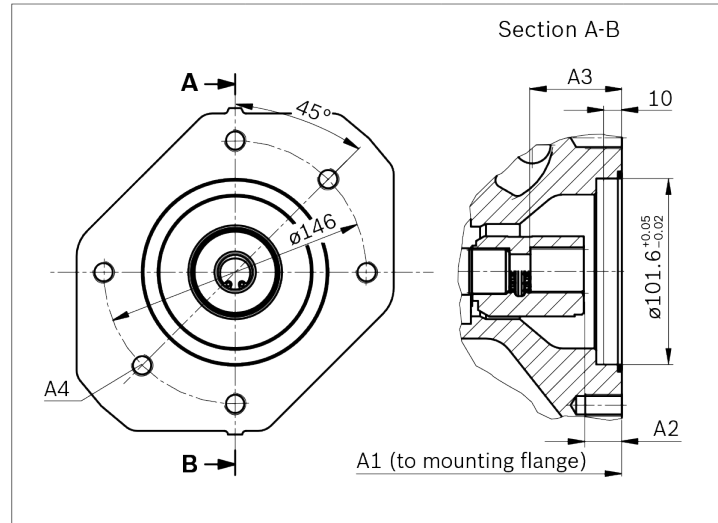
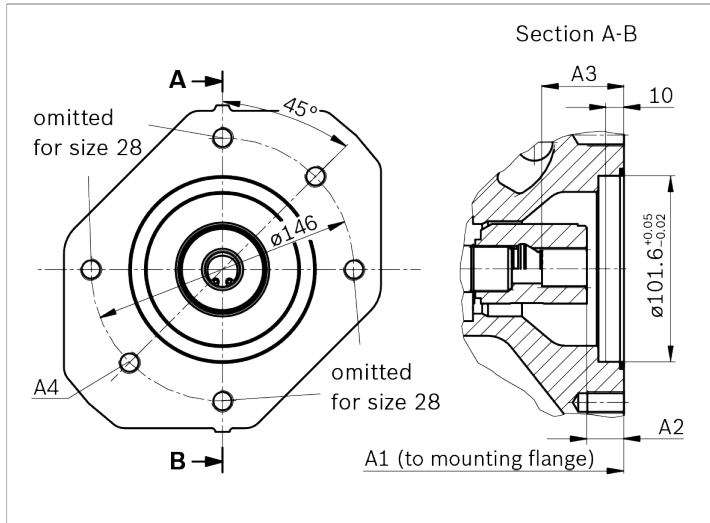

K68 (SAE J744 22-4 (B))	NG	A1	A2	A3	A4 <sup>2)</sup>
28	204	17.8	41.7	M12×1.75; <sup>3)</sup>	
45	229	17.9	41.7	M12×1.75; 18 deep	
71	267	20.3	44.7	M12×1.75; 20 deep	
88	267	20.3	44.7	M12×1.75; 20 deep	
100	338	18	41.9	M12×1.75; 20 deep	
140	350 <sup>4)</sup> 376 <sup>5)</sup>	17.8	41.6	M12×1.75; 20 deep	

K04 (SAE J744 25-4 (B-B))	NG	A1	A2	A3	A4 <sup>2)</sup>
45	229	18.4	46.7	M12×1.75; 18 deep	
71	267	20.8	49.1	M12×1.75; 20 deep	
88	267	20.8	49.1	M12×1.75; 20 deep	
100	338	18.2	46.6	M12×1.75; 20 deep	
140	350 <sup>4)</sup> 376 <sup>5)</sup>	18.3	45.9	M12×1.75; 20 deep	

- 1) According to ANSI B92.1a, 30° pressure angle, flat root, side fit, tolerance class 5
- 2) Thread according to DIN 13, see instruction manual for maximum tightening torques.
- 3) Continuous

- 4) Housing with D flange
- 5) Housing with C flange

Flange ISO 3019-1 (SAE)		Hub for splined shaft <sup>1)</sup>		Availability over sizes							Code
Diameter	Symbol	Diameter		18	28	45	71	88	100	140	
127-2 (C)	♂, ∞	1 1/4 in	14T 12/24DP	-	-	-	•	•	•	•	K07
		1 1/2 in	17T 12/24DP	-	-	-	-	-	•	•	K24

• = Available    - = Not available

▼ 127-2

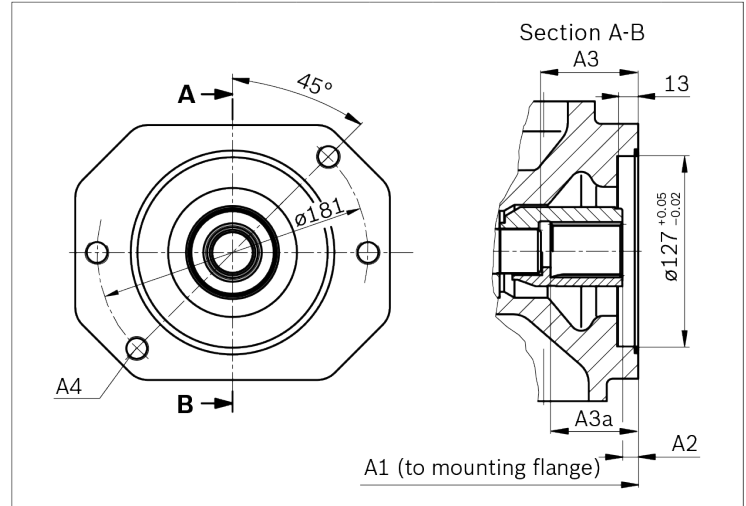
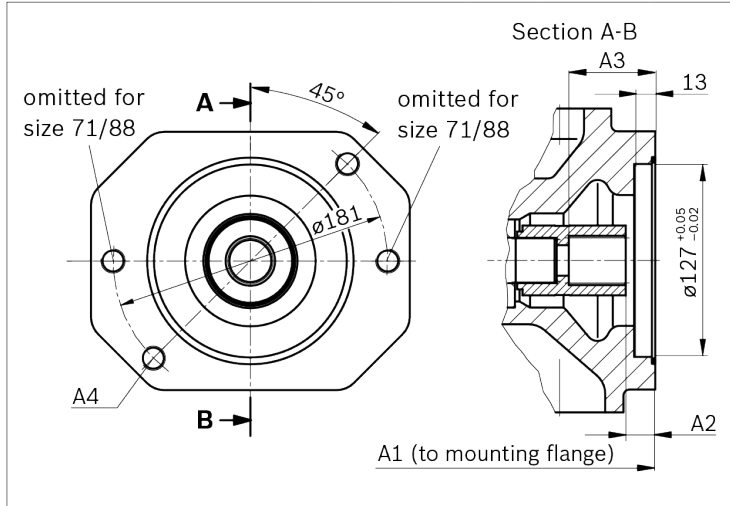

K07 (SAE J744 32-4 (C))	NG	A1	A2	A3	A4 <sup>2)</sup>
71	267	21.8	58.6	M16×2; <sup>3)</sup>	
88	267	21.8	58.6	M16×2; <sup>3)</sup>	
100	338	19.5	56.4	M16×2; <sup>3)</sup>	
140	350 <sup>4)</sup>	19.3	56.1	M16×2; 24 deep 376 <sup>5)</sup>	

K24 (SAE J744 38-4 (C-C))	NG	A1	A2	A3	A3a	A4 <sup>2)</sup>
100	338	9.9	65	-	M16×2; <sup>3)</sup>	
140	350 <sup>4)</sup>	9.7	-	69.1	M16×2; 24 deep 376 <sup>5)</sup>	

1) According to ANSI B92.1a, 30° pressure angle, flat root, side fit, tolerance class 5  
 2) Thread according to DIN 13, see instruction manual for maximum tightening torques.

3) Continuous  
 4) Housing with D flange  
 5) Housing with C flange

Flange ISO 3019-1 (SAE)		Hub for splined shaft <sup>1)</sup>	Availability over sizes						Code
Diameter	Symbol	Diameter	18	28	45	71 /88	100	140	
152-4 (D)		1 3/4 in 13T 8/16DP	-	-	-	-	-	•	K17

• = Available    - = Not available

▼ 152-4

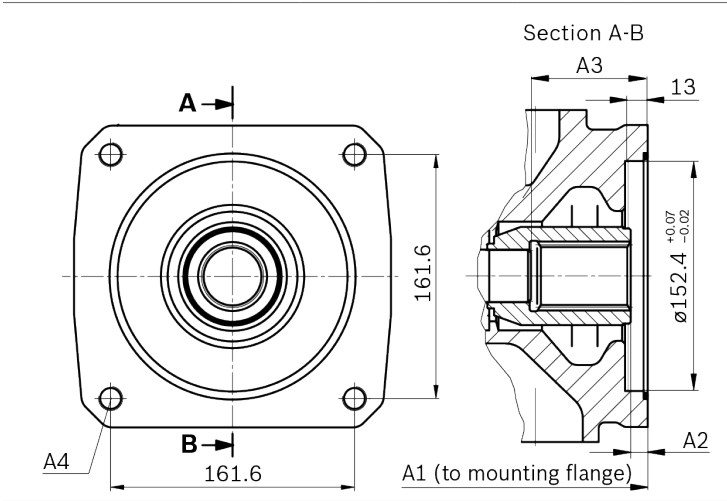

K17	NG	A1	A2	A3	A4 <sup>2)</sup>
(SAE J744 44-4 (D))					
	140	350	11	77.3	M16×2; <sup>3)</sup>

Only available with housing with mounting flange D.

- 1) According to ANSI B92.1a, 30° pressure angle, flat root, side fit, tolerance class 5
- 2) Thread according to DIN 13, see instruction manual for maximum tightening torques.
- 3) Continuous

## Overview of mounting options

### SAE – mounting flange

Through drive <sup>4)</sup>		Mounting options – 2nd pump				
Flange ISO 3019-1	Hub for splined shaft	Code	SA10V(S)O/31 NG (shaft)	SA10V(S)O/5x NG (shaft)	External gear pump design (size)	Through drive available for size
82-2 (A)	5/8 in	K01	18 (U)	10 (U), 18 (U)	Series F	18 to 140
	3/4 in	K52	18 (S, R)	10 (S) 18 (S, R)	–	18 to 140
101-2 (B)	7/8 in	K68	28 (S, R) 45 (U, W) <sup>1)</sup>	28 (S, R) 45 (U, W) <sup>1)</sup>	Series N/G	28 to 140
	1 in	K04	45 (S, R) –	45 (S, R) 60, 63, 72 (U, W) <sup>2)</sup>	–	45 to 140
127-2 (C)	1 1/4 in	K07	71 (S, R) 88 (S, R) 100 (U, W) <sup>3)</sup>	85 (U, W) <sup>3)</sup> 100 (U, W)	–	71 to 140
	1 1/2 in	K24	100 (S)	85 (S) 100 (S)	–	100 to 140
152-4 (4-hole D)	1 3/4 in	K17	140 (S)	–	–	140

## Combination pumps A10VO + A10VO

By using combination pumps, it is possible to have independent circuits without the need for splitter gearboxes. When ordering combination pumps, the type designations of the 1st and 2nd pumps must be linked by a “+”.

### Order example:

**A10VO100DFR1/31R-VSC12K04+**

**A10VO45DFR/31R-VSC12N00**

If no further pumps are to be mounted at the factory, the simple type designation is sufficient.

It is permissible to use a combination of two single pumps of the same nominal size (tandem pump) considering a dynamic mass acceleration of maximum 10 g (= 98.1 m/s<sup>2</sup>) without additional support brackets.

Each through drive is plugged with a **non-pressure-resistant** cover. Before commissioning the units, they must therefore be equipped with a pressure-resistant cover.

Through drives can also be ordered with pressure-resistant covers. Please specify in plain text.

For combination pumps consisting of more than two pumps, the mounting flange must be rated for the permissible mass torque (please contact us).

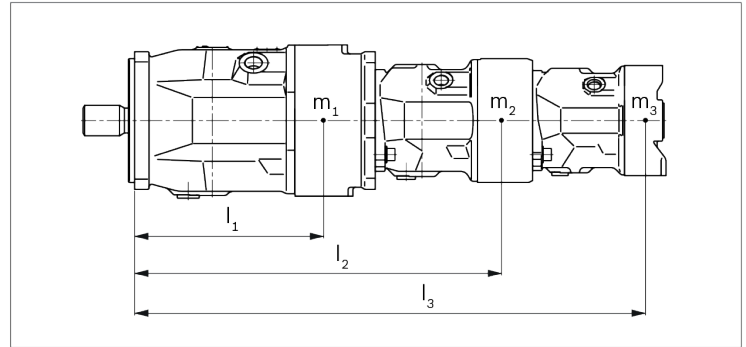

$m_1, m_2, m_3$	Weight of pump	[kg]
$l_1, l_2, l_3$	Distance, center of gravity	[mm]
$T_m = (m_1 \times l_1 + m_2 \times l_2 + m_3 \times l_3) \times \frac{1}{102} \text{ [Nm]}$		

### Permissible mass moment of inertia

Size			18	28	45	71	88	100	140
static	$T_m$	Nm	500	880	1370	2160	2160	3000	4500 <sup>1)</sup> 3000 <sup>2)</sup>
dynamic at 10 g (98.1 m/s <sup>2</sup> )	$T_m$	Nm	50	88	137	216	216	300	450 <sup>1)</sup> 300 <sup>2)</sup>
Weight <b>without</b> through drive and N00	$m$	kg	12.9	18	23.5	35.2	35.2	49.5	65.4
Weight <b>with</b> through drive and K..			13.8	19.3	25.1	38	38	55.4	74.4
Distance, center of gravity <b>without</b> through drive N00	$l_1$	mm	92	100	113	127	127	161	159
Distance, center of gravity <b>with</b> through drive K..	$l_1$	mm	98	107	120	137	137	178	180

## Connector for solenoids

### DEUTSCH DT04-2P

Molded connector, 2-pin, without bidirectional suppressor diode **P**

There is the following type of protection with mounted mating connector:

- ▶ IP67 (DIN/EN 60529) and
- ▶ IP69K (DIN 40050-9)

#### ▼ Switching symbol

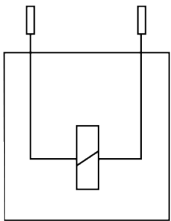

#### ▼ Mating connector DEUTSCH DT06-2S-EP04

Consisting of	DT designation
1 housing	DT06-2S-EP04
1 wedge	W2S
2 sockets	0462-201-16141

The mating connector is not included in the scope of delivery.

This can be supplied by Bosch Rexroth on request (material number R902601804).

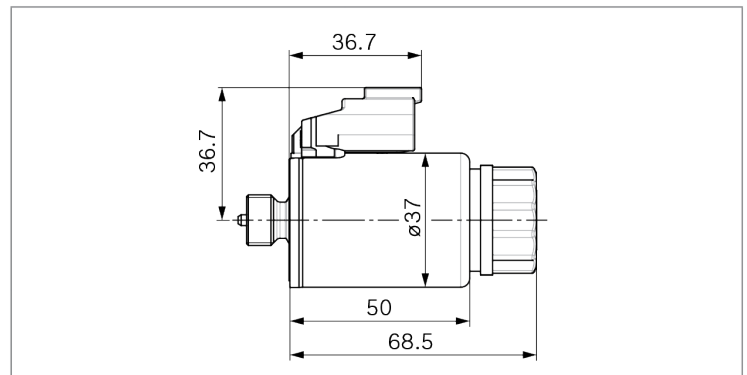

#### Notice

- ▶ If necessary, you can change the position of the connector by turning the solenoid.
- ▶ The procedure is defined in the instruction manual.

## Electronic controls

Control	Electronics function	Electronics		Further information
Electric pressure control	Controlled power outlet	RA	analog	95230
		RC4-5/30	digital	95205

# Installation instructions

## General

The axial piston unit must be filled with hydraulic fluid and air bled during commissioning and operation. This must also be observed following a longer standstill as the axial piston unit may empty via the hydraulic lines.

Particularly with the “drive shaft up/down” installation position, filling and air bleeding must be carried out completely as there is, for example, a danger of dry running. The leakage in the housing area must be discharged to the reservoir via the highest available tank port (**L**, **L<sub>1</sub>**).

If a shared drain line is used for several units, make sure that the respective case pressure is not exceeded. The shared drain line must be dimensioned to ensure that the maximum permissible case pressure of all connected units is not exceeded in any operating conditions, specifically on cold start. If this is not possible, separate reservoir lines must be laid as required.

To achieve favorable noise values, decouple all connecting lines using elastic elements and avoid above-reservoir installation.

In all operating conditions, the suction lines and the drain lines must flow into the reservoir below the minimum fluid level. The permissible suction height  $h_s$  results from the overall loss of pressure. However, it must not be higher than  $h_{s \max} = 800 \text{ mm}$ . The minimum suction pressure at port **S** must also not fall below 0.8 bar absolute during operation and during cold start.

When designing the reservoir, ensure adequate distance between the suction line and the drain line. This prevents the heated, return flow from being drawn directly back into the suction line.

### Notice

In certain installation positions, an influence on the control or closed loop control can be expected. Gravity, dead weight and case pressure can cause minor characteristic shifts and changes in response time.

Key, see page 58.

## Installation position

See the following examples **1** to **12**.

Further installation positions are available upon request.

Recommended installation position: **1** and **3**

### Below-reservoir installation (standard)

Below-reservoir installation means that the axial piston unit is installed outside of the reservoir and below the minimum fluid level of the reservoir.

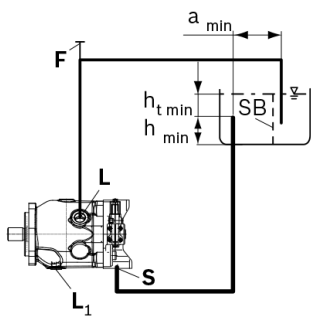
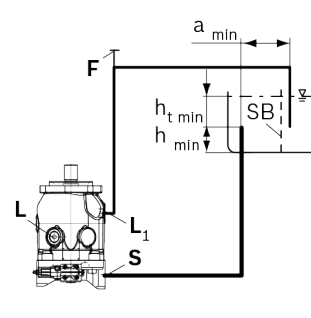
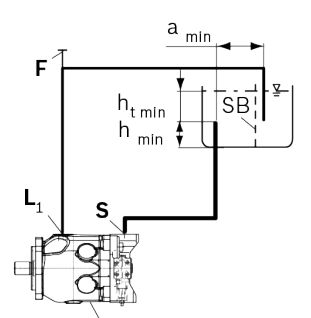
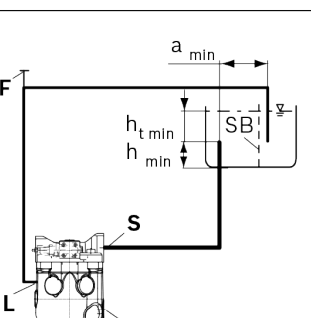
Installation position	Air bleed	Filling
<b>1</b> 	<b>F</b>	<b>L (F)</b>
<b>2<sup>1)</sup></b> 	<b>F</b>	<b>L<sub>1</sub> (F)</b>
<b>3</b> 	<b>F</b>	<b>L<sub>1</sub> (F)</b>
<b>4<sup>1)</sup></b> 	<b>F</b>	<b>L (F)</b>

1) Because complete air bleeding and filling are not possible in this position, the pump should be air bled and filled in a horizontal position before installation.

## Above-reservoir installation

Above-reservoir installation means that the axial piston unit is installed above the minimum fluid level of the reservoir. To prevent the axial piston unit from draining in position 6, the height difference  $h_{ES\ min}$  must be at least 25 mm.

Observe the maximum permissible suction height  $h_{s\ max} = 800\ mm$ . A check valve in the drain line is only permissible in individual cases. Consult us for approval.

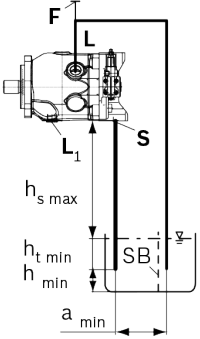
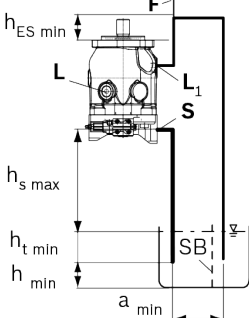
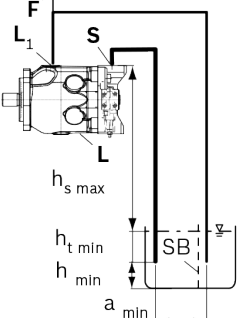
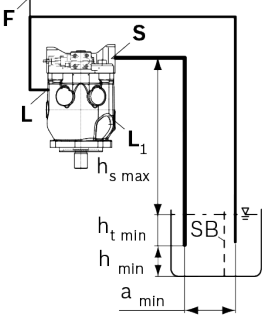
Installation position	Air bleed	Filling
<b>5</b> 	<b>F</b>	<b>L (F)</b>
<b>6<sup>1)</sup></b> 	<b>F</b>	<b>L<sub>1</sub> (F)</b>
<b>7</b> 	<b>F</b>	<b>L<sub>1</sub> (F)</b>
<b>8<sup>1)</sup></b> 	<b>F</b>	<b>L (F)</b>

Key, see page 58.

## Inside-reservoir installation

Inside-reservoir installation is when the axial piston unit is installed in the reservoir below the minimum fluid level. The axial piston unit is completely below the hydraulic fluid.

If the minimum fluid level is equal to or below the upper edge of the pump, see chapter "Above-reservoir installation".

Axial piston units with electrical components (e.g., electric control, sensors) may not be installed in a reservoir below the fluid level.

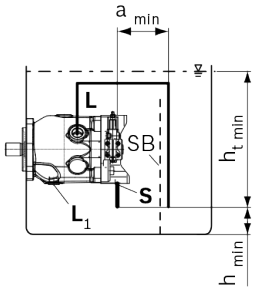
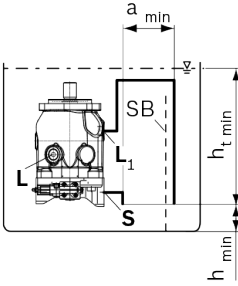
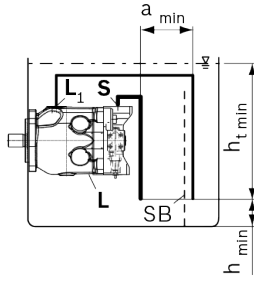
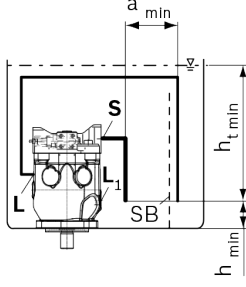
Installation position	Air bleed	Filling
<b>9</b> 	Via the highest available port <b>L</b>	Automatically via the open port <b>L</b> or <b>L<sub>1</sub></b> due to the position under the hydraulic fluid level
<b>10</b> 	Via the highest available port <b>L<sub>1</sub></b>	Automatically via the open port <b>L</b> , <b>L<sub>1</sub></b> due to the position under the hydraulic fluid level
<b>11</b> 	Via the highest available port <b>L<sub>1</sub></b>	Automatically via the open port <b>S</b> , <b>L</b> or <b>L<sub>1</sub></b> due to the position under the hydraulic fluid level
<b>12</b> 	Via the highest available port <b>L</b>	Automatically via the open port <b>S</b> , <b>L</b> or <b>L<sub>1</sub></b> due to the position under the hydraulic fluid level

1) Because complete air bleeding and filling are not possible in this position, the pump should be air bled and filled in a horizontal position before installation.

Key	
<b>F</b>	Filling / air bleeding
<b>S</b>	Suction port
<b>L; L<sub>1</sub></b>	Drain port
SB	Baffle (baffle plate)
$h_{t\ min}$	Minimum required immersion depth (200 mm)
$h_{min}$	Minimum required distance to reservoir bottom (100 mm)
$h_{ES\ min}$	Minimum necessary height required to protect the axial piston unit from draining (25 mm)
$h_{S\ max}$	Maximum permissible suction height (800 mm)
$a_{min}$	When designing the reservoir, ensure adequate distance between the suction line and the case drain line. This prevents the heated, return flow from being drawn directly back into the suction line.

### Notice

Port **F** is part of the external piping and must be provided on the customer side to make filling and air bleeding easier.

## Safety instructions

- ▶ During and shortly after operation, there is a risk of getting burnt on the axial piston unit and especially on the solenoids. Take appropriate safety measures (e.g. by wearing protective clothing).
- ▶ Moving parts in control equipment (e.g. valve pistons) can, under certain circumstances get stuck in position as a result of contamination (e.g. impure hydraulic fluid, abrasion, or residual dirt from components). As a result, the hydraulic fluid flow and the build-up of torque in the axial piston unit can no longer respond correctly to the operator's specifications. Even the use of various filter elements (external or internal flow filter) will not rule out a fault but merely reduce the risk. The machine/system manufacturer must test whether remedial measures are needed on the machine for the application concerned in order to set the consumer being driven to a safe position (e.g. safe stop) and if necessary to ensure it is properly implemented.