



SELECTION GUIDE 2007



Verberie-France



Yorkville-US



Brno-Czech Republic

Poclain Hydraulics represents:

Over 40 years of experience in power transmissions using high torque cam-lobe motors

Over 1,100 people around the world

4 manufacturing plants

11 sales subsidiaries

Over 100 distributors around the world

POCLAIN HYDRAULICS: DRIVING INNOVATION

Poclain Hydraulics is the world leader in hydrostatic transmissions integrating our unique and patented technology. With at least 6% of turnover invested in R & D, we have made innovation the pillar of an international growth strategy.

THE MARKET LEADER

Poclain Hydraulics specializes in design, manufacturing, and sales of:

- Hydrostatic transmissions and associated services
- Services for mobile machinery
- High torque cam-lobe radial piston motors

THE POCLAIN HYDRAULICS ADVANTAGE

- Constant innovation to meet your needs
- Custom transmissions
- Expert technical support
- Product or vehicle testing services
- A worldwide network of local support

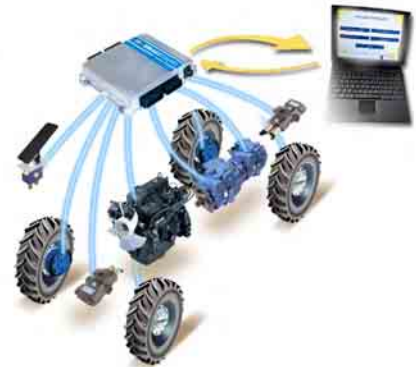

OUR MARKETS

CONSTRUCTION

Compactors, skid-steer loaders, trenchers, directional drills, excavators, ...

AGRICULTURE

Speciality harvesters, sprayers, combines, forestry vehicles, ...

MATERIAL HANDLING

Industrial and truck mounted forklifts, aerial work platforms, aircraft loaders, ...

INDUSTRIAL

Shredders, centrifuges, sugar cane elevators, ...

MARINE

Capstan winches, net drums, fishing winches, ...

CONTENT

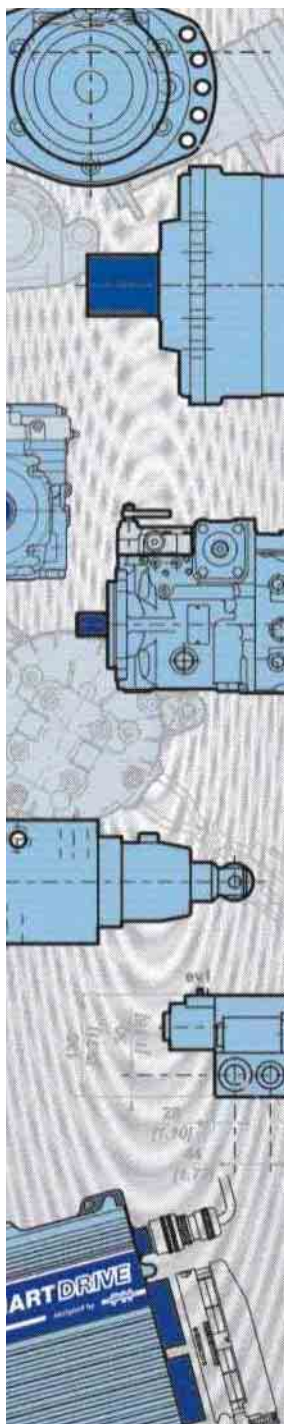

services **4** →

Services

Motors **6** →

Motors

- MS motors 7
- MK motors 14
- MG motors 18
- MZ motors 19
- ES and MF motors 20
- MD and ML motors 21
- MW motor and ADDIDRIVE™ CreepDrive 22

pumps **24** →

Pumps

- P90 pumps 24
- PL pumps 26

Circuit components **30** →

Circuit components

- VB Brake valves 30
- Circuit Valves 32
- Electro-hydraulic components 35

Electronic Control Unit **36** →

Mobile electronics

- Smartdrive™ ECU 36
- SmartDrive™ Canalogger 38

The views in this document are created using metric standards

Contact your Poclain Hydraulics representative to know our conditions of sales.

SERVICES

Working with Poclain Hydraulics Hydraulics brings peace of mind. Whoever you are and the markets you serve, we provide you with 45 years experience in hydrostatic transmissions. We offer our support at each stage of your application's life, from the drawing board to after sales, respecting quality standards that match your expectancies.

Relying on our services will allow you to:

- ✓ Optimise your transmission's performance
- ✓ Reduce time-to-market
- ✓ Reduce design risks
- ✓ Ensure a top-quality aftersales service

Product Customisation

Poclain Hydraulics designs tailored solutions to match your application's requirements.

Our resources:

- Design Department consisting of over 100 engineers
- Test lab equipped with more than 30 characteristics and endurance benches

Product customisation respects a strict and transparent step-by-step process:

- Feasibility
- Prototyping
- Testing and performance validation
- Production launch



Field Support

Working hand in hand with our customers allows us to supply custom solutions without compromising on reliability. Our technicians intervene on location to test and analyse your transmission in real life conditions.

Poclain Hydraulics' field support team is at your service to carry out:

- Prototype machine start-up and transmission optimisation.
- Troubleshooting and problem-solving for incidents relating to the transmission.

Resources:

- Worldwide network of Poclain Hydraulics expert technicians.
- Transmission Optimisation Center in France with proving grounds and test benches.
- Standard data capture and analysis tools.

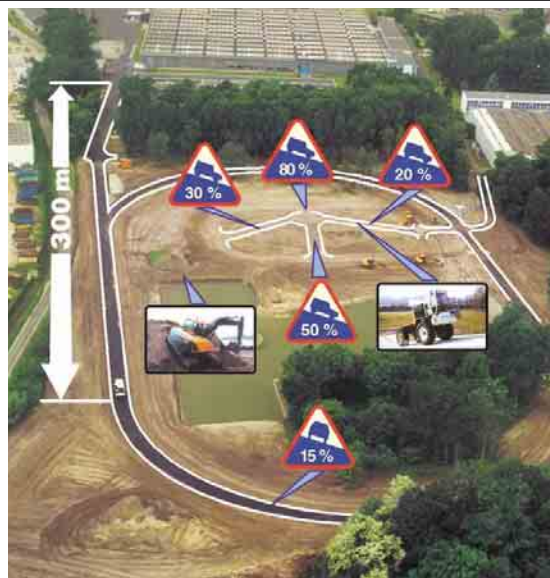

Spare parts supply

- Global inventory of parts for rapid delivery
- Fully tested genuine parts
- Parts packaged individually or in kits
- Express delivery option
- Spare parts list and exploded view supplied upon request
- OEM remanufacturing program support



Repair

Poclain Hydraulics provides you with expert aftersales technicians to inspect and repair the components that are returned.

Resources:

- Poclain Hydraulics repair centers in France, the United States, Germany, Great Britain, Italy, the Netherlands and the Czech Republic.
- Global network of qualified distributor repair centers.



Training

Poclain Hydraulics transfers its expertise to better sell, apply and repair their products.

Resources:

- Poclain Hydraulics Training Centers de formation in France and the U.S.
- Training material and manuals to transfer knowledge within your organisation.

Format:

- Standard or custom courses from two to four days, in Poclain Hydraulics facilities or on site.



Customised literature

- Copy-open pdf file
- Custom maintenance manual : Poclain Hydraulics provides you with a document that explains how to maintain and service the specific Poclain Hydraulics component(s) equipping your application.

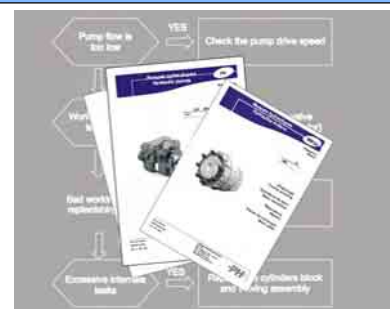

Services

Motors

Pumps

Circuit components

Mobile electronics

HIGH TORQUE CAM-LOBE MOTORS

- ✓ High pressure
- ✓ Radial piston cam-lobe motor
- ✓ Direct drive
- ✓ High efficiency
- ✓ Very low noise

MS wheel motor



MG motor



MK motor



MD motor



ES axle



ML motor



New

MZ motor



New

MF motor



MS MOTORS

- ✓ From 172 to 15 000 cm³/tr [10.5 to 915 cu.in/rev.]
- ✓ Up to 450 bar pressure [6 530 PSI]
- ✓ Up to 510 RPM
- ✓ Single or multiple displacement
- ✓ With or without brake

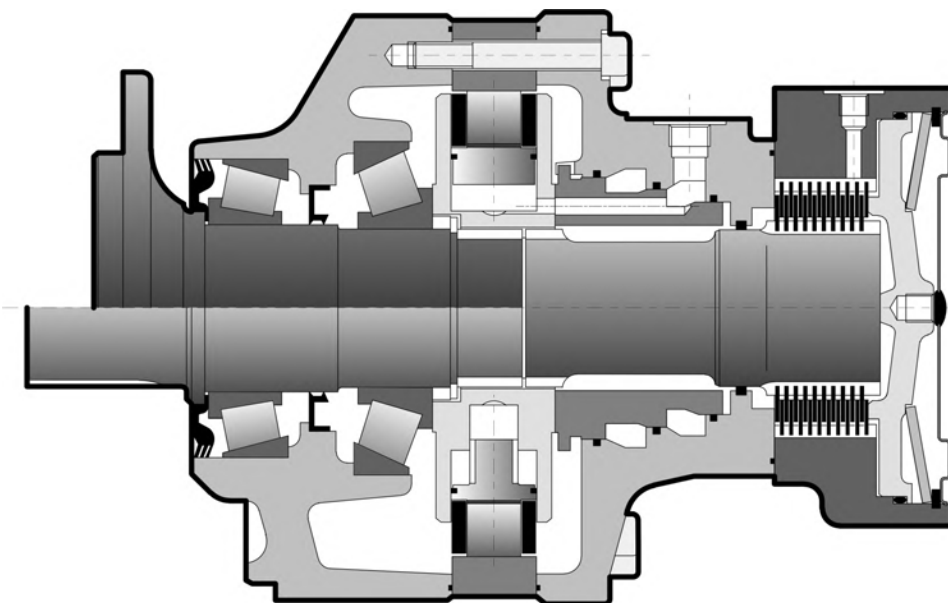
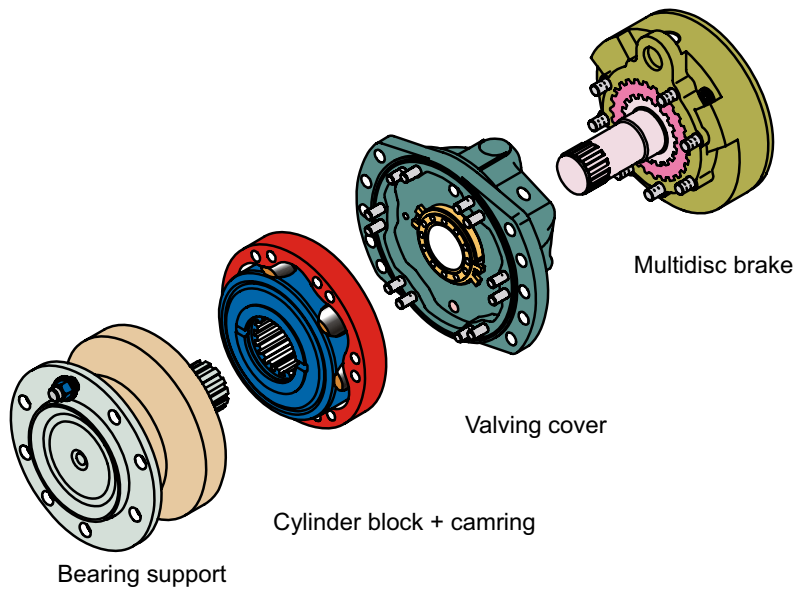

Services

Motors

Pumps

Circuit components

Mobile electronics

MS FRAMESIZES

	Displacement	Max. torque	Max. pressure	Max. speed	Max. power
Metric unitsM	cm ³ /tr	N.m	bar	tr/min	kW
[US units]	[cu.in/rev]	[lbf.ft]	[PSI]	[RPM]	[HP]

	MS 02				MSE 02			MSE 03
Displacement	172 [10.5]	213 [13.0]	235 [14.3]	255 [15.6]	332 [20.2]	364 [22.2]	398 [24.3]	500 [30.5]
Max. torque (th.)*	1200 [885]	1500 [1 106]	1 680 [1 239]	1 800 [1 227]	2 100 [1 548]	2 300 [1 696]	2 500 [1 843]	2 780 [2 050]
Max. pressure	450 [6 526]				400 [5 800]			350 [5 080]
Max. speed	510	410	372	343	275	250	230	183
Max. power	18 [24]				22 [29.5]			22 [29.5]

	MS 05					MSE 05				
Displacement	260 [15.9]	376 [22.9]	468 [28.5]	514 [31.3]	560 [34.2]	530 [32.3]	625 [38.1]	688 [42.0]	750 [45.7]	820 [50.0]
Max. torque (th.)*	1 850 [1 364]	2 700 [1 991]	3 350 [2 470]	3 680 [2 714]	4 000 [2 950]	3 360 [2 478]	4 000 [2 950]	4 380 [3 230]	4 750 [3 503]	5 200 [3 835]
Max. pressure	450 [6 526]					400 [5 800]				
Max. speed	265	250	240	220	200	200	190	175	160	145
Max. power	29 [39]									

	MS 08						MSE 08		
Displacement	467 [28.5]	627 [38.2]	702 [42.8]	780 [47.6]	857 [52.3]	934 [57.0]	1 043 [63.6]	1 146 [69.9]	1 248 [76.1]
Max. torque (th.)*	3 330 [2 456]	4 480 [3 304]	5 000 [3 687]	5 580 [4 115]	6 120 [4 513]	6 630 [4 890]	6 680 [4 926]	7 280 [5 369]	7 950 [5 863]
Max. pressure	450 [6 526]						400 [5 800]		
Max. speed	210	210	185	170	155	140	130	110	105
Max. power	41 [55]								

	MS 11						MSE 11			
Displacement	730 [44.5]	837 [51.0]	943 [57.5]	1 048 [63.9]	1 147 [70.0]	1 259 [76.8]	1 263 [77.0]	1 404 [85.7]	1 536 [93.6]	1 687 [102.9]
Max. torque (th.)*	5 220 [3 850]	6 000 [4 425]	6 750 [4 978]	7 500 [5 531]	8 200 [6 048]	9 000 [6 638]	8 040 [5 930]	8 920 [6 579]	9 800 [7 228]	10 700 [7 891]
Max. pressure	450 [6 526]						400 [5 800]			
Max. speed	200	195	190	185	180	170	170	155	140	130
Max. power	50 [67]									

MS FRAMESIZES

	MS 18						MSE 18		
Displacement	1 091 [66.5]	1 395 [85.1]	1 572 [95.9]	1 747 [106.6]	1 911 [116.6]	2 099 [128.1]	2 340 [142.8]	2 560 [156.2]	2 812 [171.6]
Max. torque (th.)*	7 800 [5 752]	10 000 [7 375]	11 250 [8 297]	12 500 [9 219]	13 650 [10 067]	15 000 [11 063]	14 900 [10 989]	16 300 [12 022]	17 900 [13 202]
Max. pressure	450 [6 526]						400 [5 800]		
Max. speed	172	164	160	155	150	145	140	125	115
Max. power	70 [94]								

	MS 25				MS 35			
Displacement	2 004 [122.3]	2 498 [152.4]	2 752 [167.9]	3 006 [183.4]	2 439 [148.8]	3 143 [191.8]	3 494 [213.2]	4 198 [256.2]
Max. torque (th.)*	14 300 [10 547]	17 850 [13 165]	19 700 [14 529]	21 500 [15 857]	17 450 [12 870]	22 500 [16 595]	25 000 [18 439]	30 000 [22 126]
Max. pressure	450 [6 526]				450 [6 526]			
Max. speed	145	137	125	115	140	140	130	110
Max. power	90 [120.7]				110 [147.5]			

	MS 50				MS 83			MS 125		
Displacement	3 500 [213.6]	4 008 [244.6]	4 997 [304.9]	6 011 [366.8]	6 679 [407.6]	8 328 [508.2]	10 019 [611.4]	10 000 [610.2]	12 500 [762.8]	15 000 [915.3]
Max. torque (th.)*	25 050 [18 476]	28 700 [21 168]	35 750 [26 367]	43 000 [31 715]	47 800 [35 255]	60 000 [44 253]	71 500 [52 735]	71 500 [52 735]	77 000 [56 792]	77 000 [56 792]
Max. pressure	450 [6 526]				450 [6 526]			450 [6 526]	380 [5 510]	320 [4 640]
Max. speed	148	138	111	92	70	60	50	50	40	30
Max. power	140 [188]				200 [268]			240 [322]		

* (th.) : theoretical torque = $1/24\pi$ x displacement (cuin/rev) x max. pressure (PSI)

All values refer to single displacement versions.
For other values, please consult the Technical Catalogs, on our web site:

 <http://www.poclain-hydraulics.com>

MS	02	03	05	08	11	18	25	35	50	83	125
 Reference technical documentation	801478186Z	801478187A	801478188B	801478189C	801478190D	801478191E	801478192F	801478193G	801478194H	801478195J	801478196K

MS BRAKES

Multidisc brake

- ✓ Failsafe: spring applied, hydraulically released
- ✓ Fully enclosed
- ✓ Choice of brake torques per motor framesize
- ✓ Can be used in an emergency to stop the vehicle



Brake	Parking N.m [lbf.ft]	Emergency N.m [lbf.ft]	02	03	05	08	11	18	25	35	50	83	125
F02	1 400 [1 032]	910 [671]	●										
F03	2 500 [1 843]	1 625 [1 198]	●	●									
FH3	3 000 [2 212]	1 950 [1 438]		●									
F04	4 220 [3 112]	2 740 [2 020]			●								
F05	3 060 [2 256]	1 990 [1 467]			●								
F08	5 620 [4 145]	3 650 [2 692]				●							
F09	9 000 [6 638]	5 850 [4 314]				●							
F11	7 280 [5 369]	4 730 [3 488]					●	●					
F12	11 840 [8 732]	7 700 [5 679]					●	●					
F19	18 600 [13 718]	12 800 [9 440]						●					
F26	26 730 [19 715]	17 375 [12 815]							●				
P35	20 500 [15 120]	20 500 [15 120]							●	●	●		
F42	25 000 [18 439]	16 250 [11 985]							●	●	●		
F50	30 000 [22 126]	22 200 [16 373]							●	●	●	●	●
F83	42 000 [30 977]	27 300 [20 135]									●	●	●

Drum brake

- ✓ Automotive service brake Parking break
- ✓ Enclosed in heavy duty bearing support
- ✓ Applied mechanically or by pressure



Brake size	Parking Emergency Service N.m [lbf.ft]	02	03	05	08	11	18	25	35	50	83	125
203 x 60	2 290 [1 689]	●										
250 x 40	2 400 [1 770]	●										
250 x 60	5 000 [3 687]			●								
270 x 60	6 000 [4 425]				●							
315 x 80	12 000 [8 850]				●	●						
350 x 60	11 000 [8 113]						●		●			
432 x 102	27 000 [19 914]						●	●	●	●		

OPTIONS

MS	C	02	03	05	08	11	18	25	35	50	83	125
Speed sensor	2	●	●	●	●	●	●	●	●	●	●	●
Mechanical free-wheeling	4			●	●							
Case flushing (additional drain port)	5	●	●	●	●	●	●	◆	◆	◆	◆	◆
Industrial bearing support	6	●		●	●	●	●	●	●	●	●	●
Diamond™ extra-long life	7	●	●	●	●	●	●	●	●	●	●	●
Chassis mounting on cam-ring side	9	●		●	●	●	●	●	●	●		
Hollow shaft	A			●	●	●	●	●	●	●	●	●
Drain on the bearing support	B	●		●	●	●	●	●	●	●	●	●
Reinforced external seals (duo-cone)	C			●	●	●	●	●	◆	◆	◆	◆
High pressure shaft sealing	E	●	●	●	●	●	●	●	●	●	●	●
High volumetric efficiency	H	●	●	●	●	●	●		●			
Heat treated shaft	J	●	●	●	●	●	●	●	●			◆
Reinforced shaft (internal splines)	K	●		●	●	●	●	◆	◆	◆	◆	◆
Higher speed	M	●		●	●	●	●	●	●	●		
Soft shift	T	●		●	●	●	●	●	●	●		

Commercial code	Available	Standard
C	●	◆

For details, please go to the Technical Catalogs.

Services

Motors

Pumps

Circuit components

Mobile electronics

MS BEARING SUPPORTS

- ✓ Double row of tapered bearings to handle high radial and axial loads
- ✓ Standard splines and wheel flange configurations available

Bearing support type



Wheel motor



Splined shaft motor

MS		02	03	05	08	11	18	25	35	50	83	125
Wheel motor		•	•	•	•	•	•	•	•	•	•	•
Splined shaft		•		•	•	•	•	•	•	•	•	•
Wheel motor, short version				•	•	•	•	•	•	•	•	•
Keyed shaft	Pinion mounting			•	•						•	
Female shaft	For shrink disc coupling								•	•	•	•
Pinion shaft	Dual sprockets for skid-steer loader	•		•								

MS VALVING COVERS



- ✓ Single or dual-displacements
- ✓ Choice of wheel and chassis mounts
- ✓ Choice of hose connections
- ✓ Twin-Lock™

Valving types

MS		02	03	05	08	11	18	25	35	50	83	125
1-displacement		•	•	•	•	•	•	•	•	•	•	•
2-displacement		•	•	•	•	•	•	•	•	•		
2-displacement symmetrical valving*							•	•	•	•	•	•
Exchange	Hot oil shuttle	•		•	•	•	•					
Twin-Lock™	Hydraulic traction control	•	•	•	•	•	•	•	•	•		
Chassis mountings	On the valving cover	•	•	•	•	•	•	•	•	•		
	Without (chassis fixation on the bearing support)	•		•	•	•	•	•	•	•	•	•

*: no preferential direction of rotation in small displacement

MS DIMENSIONS

Wheel motor

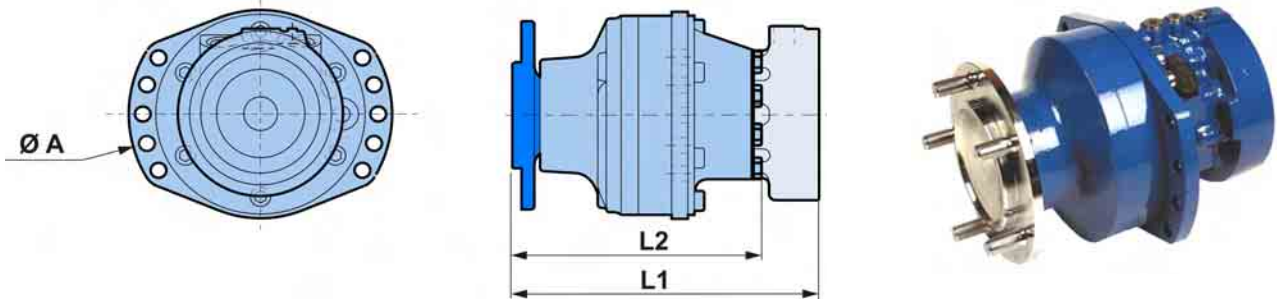

MS		02	03	05	08	11	18	25	35	50	83	125
A dia.	mm	238	238	300	335	375	425	485	485	485	555.5	555.5
	[in]	[9.37]	[9.37]	[11.81]	[13.19]	[14.76]	[16.73]	[19.09]	[19.09]	[19.09]	[21.87]	[21.87]
L1*	mm	310	296	335	367	412	476	565	591	713	797	865
	[in]	[12.20]	[11.65]	[13.18]	[14.45]	[16.22]	[18.74]	[22.24]	[23.27]	[28.07]	[31.38]	[34.05]
L2	mm	218	250	280	311	349	395	455	500	590	665	732
	[in]	[8.58]	[9.84]	[11.02]	[12.24]	[13.74]	[15.55]	[17.91]	[19.68]	[23.23]	[26.18]	[28.82]
Weight*	kg	31	32	50	79	112	150	270	269	415	503	563
	[lb]	[68]	[70]	[110]	[174]	[247]	[330]	[596]	[593]	[915]	[1 109]	[1 241]

*: 1C wheel motor with multidisc brake corresponding to the motor size

Splined shaft

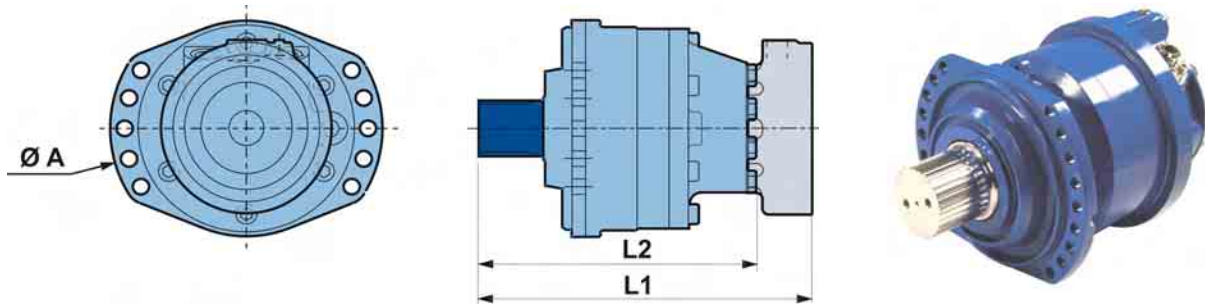

MS		02	03	05	08	11	18	25	35	50	83	125
A dia.	mm	238	N.A	300	335	375	425	485	425	395	565	565
	[in]	[9.37]	N.A	[11.81]	[13.19]	[14.76]	[16.73]	[19.09]	[16.73]	[15.55]	[22.24]	[22.24]
L1	mm	310	N.A	366	392	443	517	635	670	810	890	957
	[in]	[12.20]	N.A	[14.41]	[15.43]	[17.44]	[20.35]	[25]	[26.38]	[31.89]	[35.04]	[37.68]
L2*	mm	255	N.A	308	336	380	432	525	580	678	757	825
	[in]	[10.04]	N.A	[12.13]	[13.23]	[14.96]	[17.00]	[20.67]	[22.83]	[26.70]	[29.80]	[32.48]
Weight*	kg	21	N.A	41	62	88	112	195	188	265	410	470
	[lb]	[46.3]	N.A	[90.4]	[136.6]	[194]	[247]	[430]	[414.5]	[584]	[904]	[1 036]

*: 1C splined shaft motor, without brake

For details, please go to the Technical Catalogs.

MK MOTORS

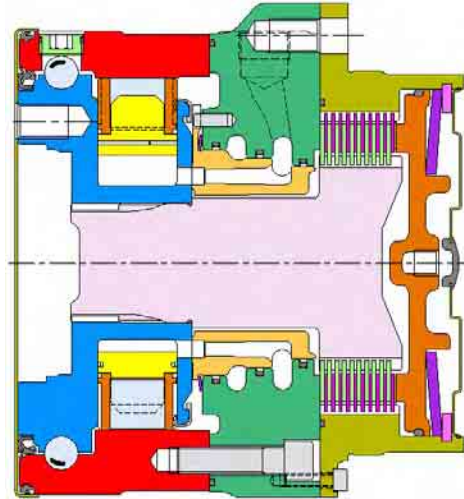

- ✓ From 270 to 5 625 cm³/tr [16.5 to 343 cu.in/rev.]
- ✓ Ultra-slim motor
- ✓ Large diameter 4 contact roller bearing
- ✓ Reinforced shaft sealing
- ✓ Hollow shaft available

	Displacement	Max. torque	Max. pressure	Max. speed	Max. power
Metric unitsM	cm ³ /tr	N.m	bar	tr/min	kW
[US units]	[cu.in/rev]	[lb.ft]	[PSI]	[RPM]	[HP]

	MK 04			MKD 04		
Displacement	272 [16.6]	408 [24.9]	456 [27.8]	502 [30.6]	545 [33.2]	
Max. torque (th.)	1 730 [1 275]	2 600 [1 917]	2 610 [1 925]	2 873 [2 119]	3 120 [2 301]	
Max. pressure	400 [5 800]			400 [5 800]		
Max. speed	150	100	90	82	75	
Max. power	18 [24]			18 [24]		

	MK 05				MK09			
Displacement	272 [16.6]	447 [27.3]	558 [34.0]	670 [40.9]	667 [40.7]	750 [45.7]	833 [50.8]	1000 [61.0]
Max. torque (th.)	1 730 [1 275]	2 840 [2 094]	3 550 [2 618]	4 250 [3 134]	4 240 [3 127]	4 770 [3 518]	5 300 [3 909]	6 360 [4 690]
Max. pressure	400 [5 800]				400 [5 800]			
Max. speed	130	80	65	55	100	90	80	65
Max. power	22.5 [30]				30 [40]			

MK MOTORS

MK 12					MKE 12					
Displacement	627 [38.2]	702 [42.8]	780 [47.6]	857 [52.3]	934 [57.0]	1 043 [63.6]	1 146 [69.9]	1 248 [76.1]	1 356 [82.7]	
Max. torque (th.)	4 480 [3 304]	5 000 [3 687]	5 580 [4 115]	6 120 [4 513]	6 680 [4 926]	6 630 [4 890]	7 280 [5 369]	7 950 [5 863]	8 630 [6 365]	
Max. pressure	450 [6 526]					450 [6 526]				
Max. speed	100					100				
Max. power	41 [55]					41 [55]				

MK 18						MKE 18				
Displacement	1 091 [66.6]	1 395 [85.1]	1 571 [95.8]	1 747 [106.6]	1 911 [116.6]	2 099 [128.0]	2 340 [142.8]	2 560 [156.2]	2 808 [171.3]	
Max. torque (th.)	7 800 [5 752]	10 000 [7 375]	11 250 [8 297]	12 500 [9 219]	13 650 [10 067]	15 000 [11 063]	14 900 [10 989]	16 370 [12 073]	17 950 [13 239]	
Max. pressure	450 [6 526]						400 [5 800]			
Max. speed	170	165	160	155	150	145	140	125	115	
Max. power	70 [94]									

MK 23		MKE 23			MK 35			MK 47		
Displacement	1 747 [106.6]	2 099 [128.1]	2 340 [142.8]	2 560 [156.2]	2 808 [171.3]	3 143 [191.8]	3 494 [213.2]	4 198 [256.2]	4 680 [285.6]	5 624 [343.2]
Max. torque (th.)	12 500 [9 219]	15 000 [11 063]	14 900 [10 989]	16 370 [12 073]	17 950 [13 239]	22 500 [16 595]	25 000 [18 439]	30 000 [22 126]	29 750 [21 942]	35 750 [26 367]
Max. pressure	450 [6 526]		400 [5 800]			450 [6 526]			400 [5 800]	
Max. speed	65	65	65	65	65	50	50	50	50	50
Max. power	70 [94]					110 [147.5]			110 [147.5]	

To know the other values, please consult the Technical Catalogs, on our website:

 <http://support.poclain-hydraulics.com>

MK	04	D04	05	09	12	18	23	35	47
 Reference technical documentation	801578146B	A08998F	801578147C	801578156M	801578150F	801578152H	801578153J	801578154K	801578155L

MK VALVING COVERS



- ✓ Single or dual-displacement
- ✓ Parking and emergency brake
- ✓ Axial porting available in size 05

Valving types

New

MK		04	D04	05	05 ²	09	12	18	23	35	47
1-displacement		●	●	●	●	●	●	●	●	●	●
2-displacement							●	●	●	●	●
2-displacement symmetrical valving ¹								●	●	●	●
Exchange	Hot oil shuttle						●	●	●		
Twin-Lock™	Hydraulic traction control						●	●	●		
Axial porting	Porting integrated into chassis mounting flange				●						
Multidisc brake	Integrated			●		●	●		●	●	●
	Mounted at the rear of the motor							●			
Claw brake	Integrated	●	●		●						
Speed sensor		●	●	●	●	●	●	●	●	●	●
Hollow shaft		●	●		●	●	●				

1: no preferential direction of rotation in small displacement
 2: with axial porting

MK DIMENSIONS

MK04

MKD04

New

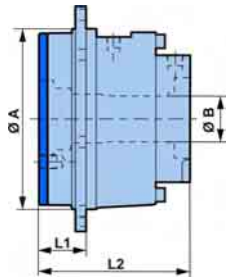

MK05

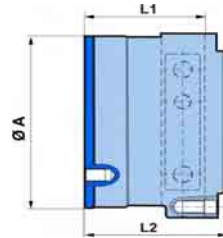

MK05 axial

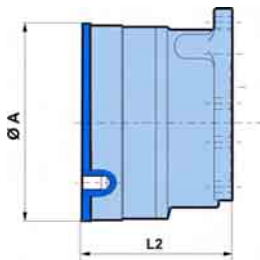

MK12-E12

MK23-E23

MK35

MK47

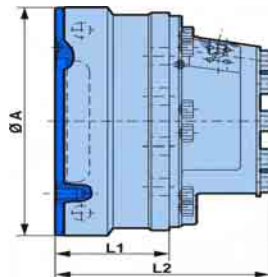

MK09

Under development

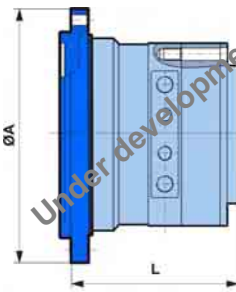

MK18-E18

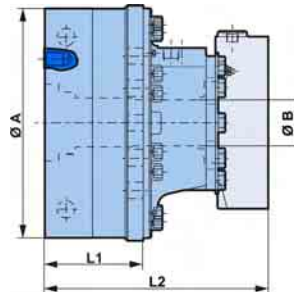

New

MK		04	D04	05	05 ²	09	12	18	23	35	47
A dia.	mm	205	205	216	216	247	327	330	388	388	388
	[in]	[8.07]	[8.07]	[8.50]	[8.50]	[9.72]	[12.87]	[12.99]	[15.27]	[15.27]	[15.27]
B dia.	mm	36	36	N.A	38	61	36	N.A	N.A	N.A	N.A
	[in]	[1.42]	[1.42]		[1.50]	[2.40]	[1.42]				
L	mm	173	176	175	165	191	306	346	366	409	415
	[in]	[6.81]	[6.92]	[6.89]	[6.50]	[7.52]	[12.05]	[13.62]	[14.41]	[16.10]	[16.34]
Weight	kg	31	31	40	35	50	82	122	128	175	180
	[lb]	[68]	[68]	[88]	[77]	[110]	[181]	[269]	[282]	[386]	[397]

²: with axial porting

MG MOTORS

- ✓ 90° steering angle
- ✓ Up to 450 bar [6 530 PSI]
- ✓ From 830 to 2 800 cm³/tr [51 to 154 cu.in/rev]
- ✓ The two-speed configuration allows the operator to adjust torque to ground conditions;
- ✓ Integral hydraulic displacement shift solenoid eliminates hydraulic control pressure line; Cilindrada
- ✓ Integral hydraulic swivel eliminates hose and fitting wear caused by hose bending;
- ✓ Simple bolt-on mounting simplifies vehicle assembly;
- ✓ Optional pivot bracket.



Dimensions

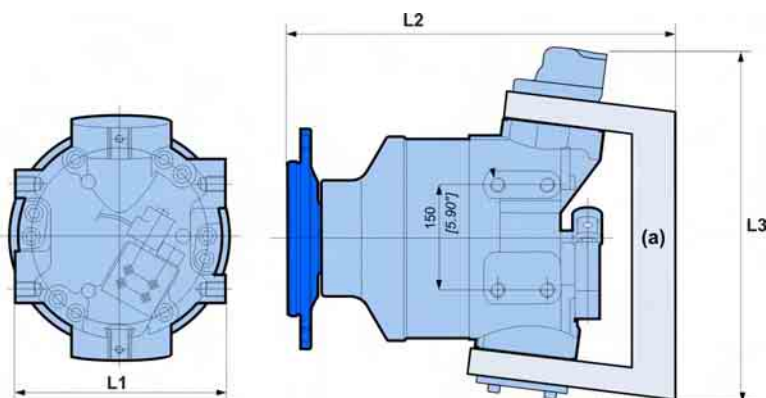

MG		11	21
L1	mm	300	300
	[in]	[11.81]	[11.81]
L2	mm	510	555
	[in]	[20.08]	[21.85]
L3	mm	505	505
	[in]	[19.88]	[19.88]
Weight	kg	210	230
	[lb]	[463]	[507]

MG characteristics

	Displacement	Max. torque	Max. pressure	Max. speed	Max. power
Metric unitsM	cm ³ /tr	N.m	bar	tr/min	kW
[US units]	[cu.in/rev]	[lbf.ft]	[PSI]	[RPM]	[HP]

	MG11					MG21			
Displacement	837	943	1 048	1 147	1 259	1 674	1 886	2 096	2 294
	[51.1]	[57.5]	[63.9]	[70.0]	[76.8]	[102.1]	[115.1]	[128.1]	[140]
Max. torque (th.)	6 000	6 750	7 500	8 200	9 000	12 000	13 500	15 000	16 400
	[4 425]	[4 978]	[5 531]	[6 048]	[6 638]	[8 850]	[9 957]	[11 063]	[12 096]
Max. pressure	450 [6 526]					400 [5 800]			
Max. speed	170					110			
Max. power	50 [67]					80 [107]			



MZ MOTORS

Services

Motors

Pumps

Circuit components

Mobile electronics

- ✓ For slewing drive,
- ✓ Direct drive,
- ✓ Up to 450 bar [6 530 PSI],
- ✓ High efficiency,
- ✓ Compactness,
- ✓ Pinion shaft, integrated hot oil shuttle and break.



Motors

Capacity of the excavator	tonnes [ton]	2 at 4.5 [1.97 at 4.4]	4.5 at 7 [4.4at 6.9]	7 at 10 [6.9 at 9.8]	10 at 14 [9.8 at 13.8]
MZ		04	07	10	14
A dia.	mm [in]	245 [9.65]	300 [11.81]	335 [13.19]	435 [17.13]
M	mm [in]	224 [8.82]	264 [10.39]	310 [12.2]	375 [14.76]
L	mm [in]	310 [12.2]	392 [15.43]	428 [16.85]	442 [17.4]
Parking brake		●	●	●	●
Theoretical torque at 100 bar	daN.m [lbf.ft]	43 at 87 [318 at 640]	74 at 130 [548 at 961]	124 at 198 [914 at 1463]	166 at 268 [1222 at 1977]
Weight	kg [lb]	37 [81.5]	47 [103.6]	85 [187.4]	114 [251.3]

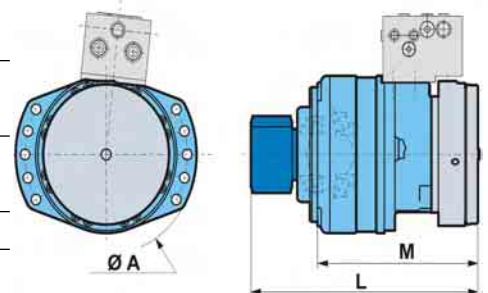

Valves fonctions

MZ	04	07	10	14
Anti-rebond Anti dumping Anti-shock	●	●	●	●
Automatic brake release	●	●	●	

ES AXLES

- ✓ Axles for industrial lift trucks between 1.5 and 5 ton operating capacity
- ✓ From 215 to [13.0 to 47.5 cu.in/rev.]
- ✓ Mounting for the mast
- ✓ Two hydrobases
- ✓ Large hot oil shuttle
- ✓ Multidisc brakes

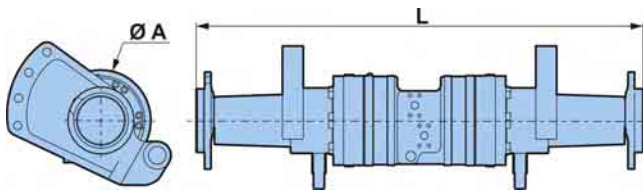
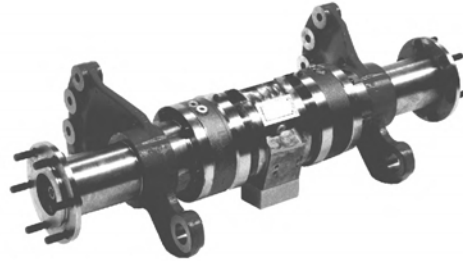

	ES	02	05	08
A dia.	mm [in]	185 [7.28]	245 [9.65]	315 [12.40]
L	mm [in]	960 [37.80]	1 180 [46.45]	1 285 [50.60]
Weight	kg [lb]	130 [287]	180 [397]	320 [705.5]
Displacement	cm ³ /tr [cu.in/rev.]	213 [13.0]	468 [28.6]	780 [47.6]
Max. torque	N.m [lbf.ft]	1 500 [1 106]	3 350 [2 470]	5 600 [4 130]
Max. pressure	bar [PSI]	450 [6 526]		
Max. speed	RPM	310	240	170

Documentation n° A08002X

To know the other available displacements, consult the MS range displacement table, p °



MF HYDROBASES

- ✓ Hydraulic assist drive for on road and off road applications.
- ✓ Rotating cam motor with integrated free wheeling system

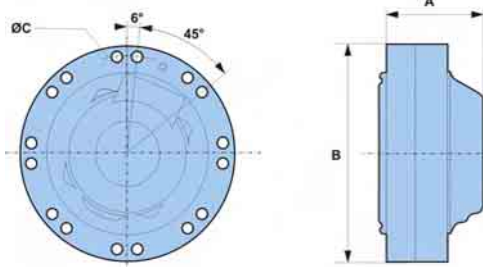

MF	08	E08	18	
1-displacement	●		●	
2-displacement			●	
Displacement	cm ³ /tr [cu.in/rev.]	780 [47.6]	1 043 [63.6]	1 747 [106.5]
Max. torque	N.m [lbf.ft]	5 580 [4 100]	7 280 [5 370]	12 500 [9 210]
Max. pressure	bar [PSI]	450 [6 350]	400 [5 800]	450 [6 350]
Max speed	RPM	140	125	145
Max. speed in free-wheeling	RPM	600		-
Max. power	kW [HP]	41 [55]	41 [55]	70 [94]
A	mm [in]	105 [4.13]		188 [7.40]
B dia.	mm [in]	257 [10.12]		334 [13.15]
C dia.	mm [in]	230 [9.29]		295 [11.61]

MD MOTOR

- ✓ For pneumatic and combi rollers
- ✓ Drives two wheels at once
- ✓ Multidisc brake

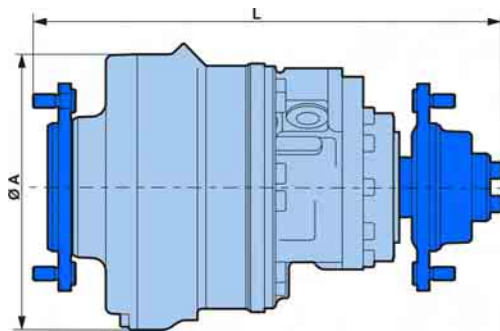

For the other available displacements, consult the MS range displacement table, p 8.

MD		11
Displacement	cm ³ /tr [cu.in/rev.]	1 048 [64.0]
Max. torque	N.m [lbf.ft]	7 500 [5 531]
Max. pressure	bar [PSI]	450 [6 526]
Max. speed	RPM	185
Max. power	kW [HP]	50 [67]
Max. braking torque	N.m [lbf.ft]	7 000 [5 163]
A dia.	mm [in]	328 [12.91]
L	mm [in]	565 [22.24]
Weight	kg [lb]	140 [308.6]

Services

Motors

ML MOTOR

- ✓ For skid-steer loaders
- ✓ 2-displacement
- ✓ Integrated oil exchange
- ✓ Soft shift

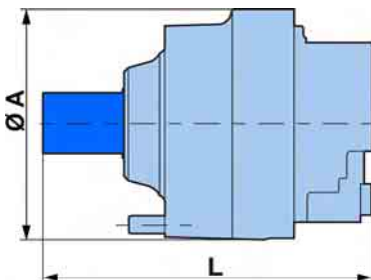

ML		06	E06	
Displacement	cm ³ /tr [cu.in/rev.]	630 [38.44]	702 [42.84]	842 [51.38]
Max. torque	N.m [lbf.ft]	3 800 [2 800]	4 240 [3 127]	5 087 [3 752]
Max. pressure	bar [PSI]	380 [5 511]		
Max. speed	RPM	226	322	241
Max. power	kW [HP]	30 [22]		
Max. braking torque	N.m [lbf.ft]	4 500 [3 319]		
A dia.	mm [in]	233 [9.17]		
L	mm [in]	338 [13.31]		
Weight	kg [lb]	50 [110.2]		

Documentation n° | A02305F (dvplt)

Pumps

Circuit components

Mobile electronics

MW MOTOR

New



- ✓ From 4 333 to 5 167cm³/ [264.5 to 315.5 cu.in/rev.]
- ✓ Up to 160 RPM
- ✓ 3 displacements
- ✓ High efficiency throughout the speed range
- ✓ Low noise level

Dimensions

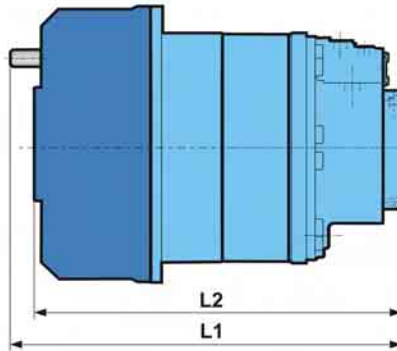
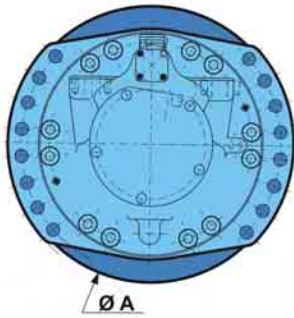

	MS	50
A dia.	mm	485
	[in]	[19.09]
L1*	mm	606
	[in]	[23.85]
L2	mm	594
	[in]	[23.39]
Weight*	kg	435
	[lb]	[1 069]

ADDIDRIVE™ CREEPDRIVE

New

ADDIDRIVE™ CreepDrive is the ideal transmission for vehicles that need to travel fast between working sites, yet must work at a low and constant speed.

The CDM170-050 motor is at the heart of the system. Mechanically linked to the transmission shaft at its input and output, it is placed between the transmission and the differential. Light and compact package, it can fit every type of transmission brand. Moreover, it eases the remote control of the machine.

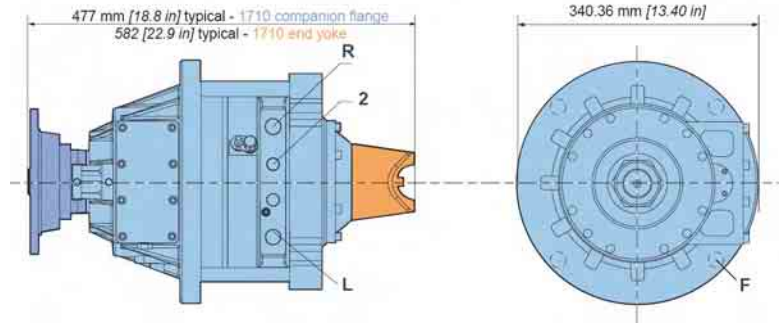

Specifications

Displacement	cm ³ /tr	667	750	833
	Cu.in/rev	[40.7]	[45.7]	[50.8]
Torque	Nm (275bar)	2 880	3 240	3 597
	lb-ft (3 990PSI)	2 124	2 390	2 653
Speed	RPM	200	185	170
Power	kW		40	
	HP		54	

Services

Motors

Pumps

Circuit components

Mobile electronics

P90 PUMPS

New

- ✓ Variable displacement
- ✓ For closed loop circuits
- ✓ Rugged and compact
- ✓ Integral charge pump
- ✓ Low noise level
- ✓ Tandem mounting available



	P90
--	-----

 Reference feature documentation

P90 PUMPS

New

- ✓ Variable displacement
- ✓ Up to 480 bar pressure [6 962 PSI]
- ✓ Single or tandem
- ✓ Three frame sizes
- ✓ Six displacements
- ✓ For use in Poclain Hydraulics systems and SmartDrive™
- ✓ Rear auxiliary mount :
 - SAE A, B, C, D, E

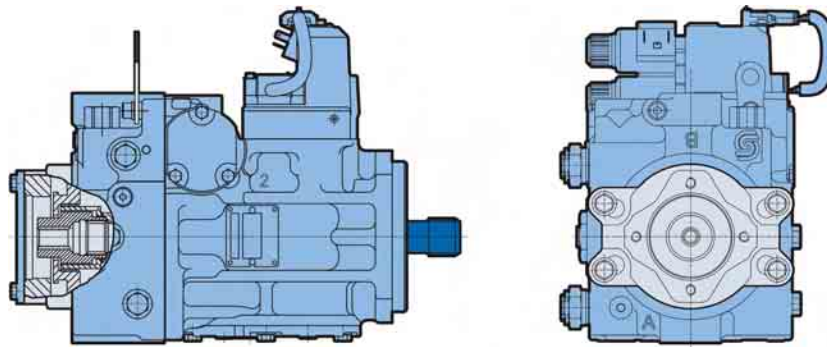
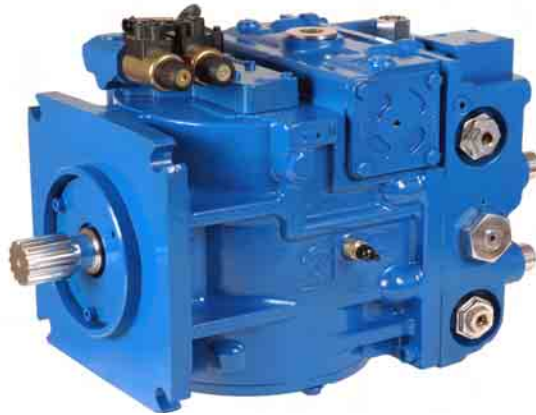

	P90	055	075	100	130	180	250
Displacement	cm ³ /tr [cu.in/rev.]	55 [3.35]	75 [4.58]	100 [6.10]	130 [7.93]	180 [10.98]	250 [15.25]
Max. pressure	bar [PSI]	480 [6 962]					
Max. speed	RPM	4 250	3 950	3 650	3 400	2 850	2 500
Weight	kg [lb]	40 [88.2]	49 [108]	68 [150]	88 [194]	136 [300]	154 [340]

Options available on the entire range

- ✓ Speed sensor

Services

Motors

Pumps

Circuit components

Mobile electronics

PL PUMPS

- ✓ Fixed displacement
- ✓ For open loop circuits
- ✓ Up to 450 bar [6 530 PSI] pressure
- ✓ Sizes 10 to 444 cm³/tr [0.63 to 27 cu.in/rev]
- ✓ In line radial pistons
- ✓ High speed for engine drive
- ✓ High efficiency
- ✓ High durability
- ✓ Independent output flows

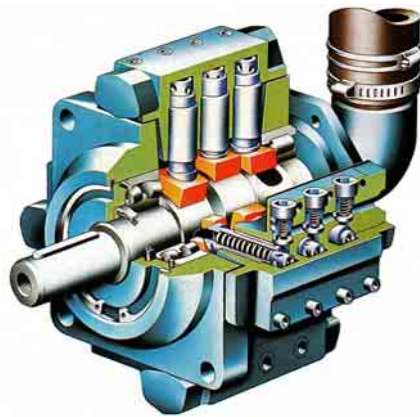

Single output flow

PL 1H14	mm	[in]
L1	397	[15.63]
L2	230	[9.05]
L3	225	[8.86]
	kg	[lb]
Weight	28	[62]

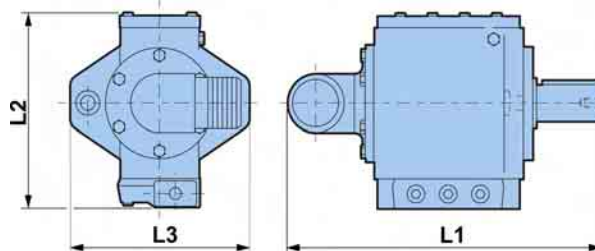

Pump type	PL1H14						
Displacement	cm ³ /tr [cu.in/rev.]	17.5 [1.07]	20 [1.22]	22 [1.34]	25 [1.53]	28.5 [1.74]	32 [1.95]
Max. pressure	bar [PSI]	450 [6 526]					
Max. speed	RPM	3 100	3 000	2 900	2 800	2 600	2 400
Max. power	kW [HP]	41 [55]	45 [60]	48 [64]	52 [70]	56 [75]	58 [78]

PL PUMPS

Two output flows

PL 2H14	mm	[in]
L	397	[15.63]
A dia.	320	[12.60]
	kg	[lb]
Weight	38	[84]

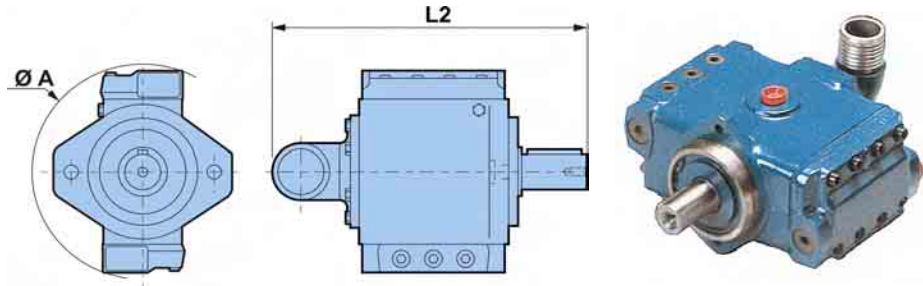

Pump type	PL2H14						
Displacement	cm ³ /tr [cu.in/rev.]	2 x 17.5 [2 x 1.07]	2 x 20 [2 x 1.22]	2 x 22 [2 x 1.34]	2 x 25 [2 x 1.53]	2 x 28.5 [2 x 1.74]	2 x 32 [2 x 1.95]
Max. pressure	bar [PSI]	450 [6 526]					
Max. speed	RPM	3 100	3 000	2 900	2 800	2 600	2 400
Max. power	kW [HP]	81 [109]	90 [121]	96 [129]	105 [141]	111 [149]	115 [154]

Three output flows

PL 3H14	mm	[in]
A dia.	320	[12.60]
L	397	[15.63]
	kg	[lb]
Weight	47	[104]

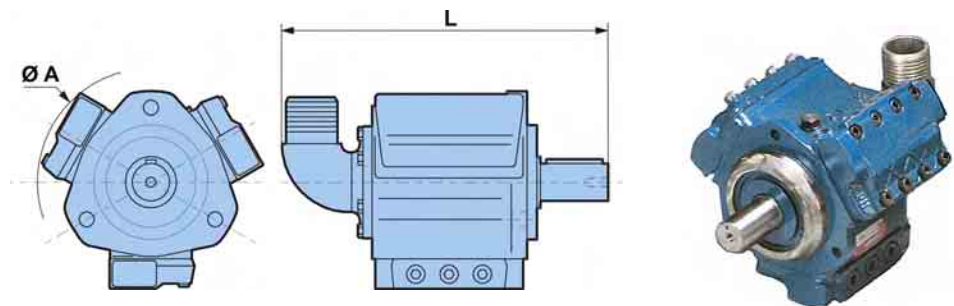

Pump type	PL3H14							
Displacement	cm ³ /tr [cu.in/rev.]	3 x 17.5 [3 x 1.07]	3 x 20 [3 x 1.22]	3 x 22 [3 x 1.34]	3 x 25 [3 x 1.53]	3 x 28.5 [3 x 1.74]	3 x 32 [3 x 1.95]	3 x 37 [3 x 2.26]
Max. pressure	bar [PSI]	450 [6 526]						
Max. speed	RPM	3 400	3 200	3 100	3 000	2 800	2 500	2 400
Max. power	kW [HP]	134 [180]	144 [193]	153 [205]	169 [227]	180 [241]	180 [241]	180 [241]

PL PUMPS

Four independent output flows

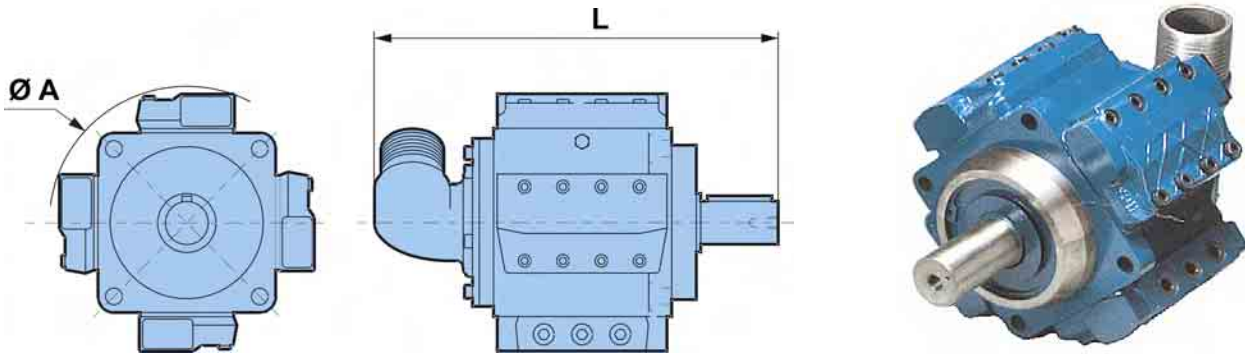

Pump type		PL4H10		PL4H18			PL4H20	
Displacement	cm ³ /tr	4 x 10.3	4 x 12.5	4 x 33	4 x 44	4 x 52	4 x 58	4 x 74
	[cu.in/rev.]	[4 x 0.63]	[4 x 0.76]	[4 x 2.01]	[4 x 2.69]	[4 x 3.17]	[4 x 3.54]	[4 x 4.52]
Max. pressure	bar [PSI]	450 [6 526]		450 [6 526]			450 [6 526]	
Max. speed	RPM	2 700		2 500	2 500	2 400	2 400	2 300
Max. power	kW [HP]	84 [113]	102 [137]	246 [330]	330 [442]	376 [504]	417 [559]	510 [684]
A dia.	mm [in]	275 [10.83]		440 [17.32]			550 [21.65]	
L	mm [in]	376 [14.80]		550 [21.65]			656 [25.83]	
Weight	kg [lb]	42 [93]		140 [309]			250 [551]	

Pump type		PL4H14						
Displacement	cm ³ /tr	4 x 17.5	4 x 20	4 x 22	4 x 25	4 x 28.5	4 x 32	4 x 37
	[cu.in/rev.]	[4 x 1.07]	[4 x 1.22]	[4 x 1.34]	[4 x 1.53]	[4 x 1.74]	[4 x 1.95]	[4 x 2.26]
Max. pressure	bar [PSI]	450 [6 526]						
Max. speed	RPM	3 100	2 900	2 800	2 600	2 400	2 200	2 000
Max. power	kW [HP]	163 [219]	174 [233]	185 [248]	195 [261]	205 [275]	211 [283]	222 [298]
Adia.	mm [in]	320 [12.60]						
L	mm [in]	435 [17.13]						
Weight	kg [lb]	68 [150]						

PL PUMPS

Six independent output flows

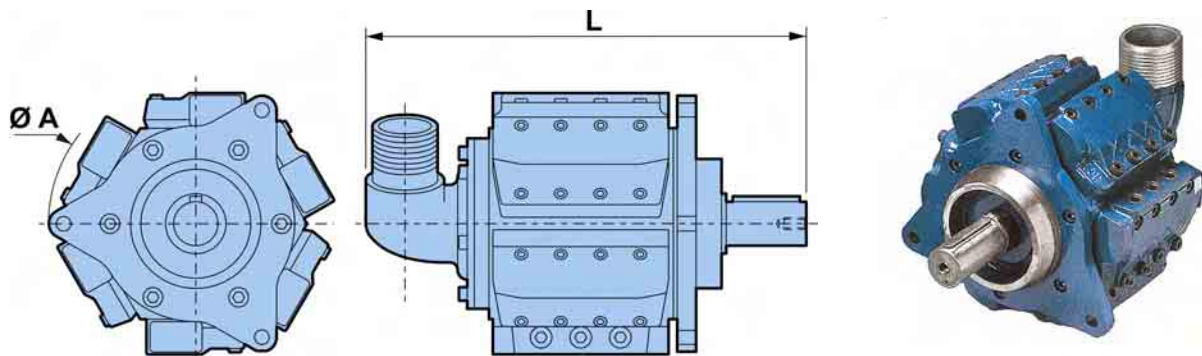

Pump type	PL6H14						
Displacement	cm ³ /tr [cu.in/rev.]	6 x 17.5 [6 x 1.07]	6 x 20 [6 x 1.22]	6 x 22 [6 x 1.34]	6 x 25 [6 x 1.53]	6 x 28.5 [6 x 1.74]	6 x 32 [6 x 1.95]
Max. pressure	bar [PSI]	450 [6 526]					
Max. speed	RPM	3 200	3 000	2 800	2 700	2 500	2 300
Max. power	kW [HP]	252 [338]	270 [362]	277 [371]	304 [408]	320 [429]	331 [444]
A dia.	mm [in]	352 [13.86]					
L	mm [in]	463 [18.23]					
Weight	kg [lb]	84 [185]					

Pump type	PL6H20			
Displacement	cm ³ / [cu.in/rev.]	6 x 58 [6 x 3.54]	6 x 65 [6 x 3.97]	6 x 74 [6 x 4.52]
Max. pressure	bar [PSI]	450 [6 526]		
Max. speed	RPM	2 400	2 200	2 000
Max. power	kW [HP]	626 [839]	643 [862]	666 [893]
A dia.	mm [in]	550 [21.65]		
L	mm [in]	659 [25.94]		
Weight	kg [lb]	360 [794]		

For more information, please consult the Technical Catalogs, on our web site:
<http://www.poclain-hydraulics.com>









Technical catalog	PL A08974E
-------------------	----------------------

VB BRAKE VALVES

- ✓ Compact
- ✓ Smooth progressive control
- ✓ Can be integrated to existing braking circuit





Brake actuators

- ✓ More safety, performance & reliability
- ✓ Brake pressure proportional effort
- ✓ For single & dual circuit
- ✓ Small, lightweight package
- ✓ Pression max. de 120 bar

VB type	VB 010	VB 020	VB 002	VB 0B0	VB 012	VB 022	VB00E
							 New
Service brake	●	●		●	●	●	
Parking brake			●				●
Single-circuit	●		●	●	●		
Dual-circuit ¹		●				●	●
Brake valve type	modulating	modulating	reverse modulating	modulating steering-assisted	combined	combined	reverse modulating
Length ²	mm [in] 50 [1.97]	60 [2.36]	50 [1.97]	135 [5.31]	140 [5.51]	132 [5.20]	74 [2.91]
Width ²	mm [in] 35 [1.38]	60 [2.36]	35 [1.38]	60 [2.36]	60 [2.36]	60 [2.36]	121 [4.76]
Height ²	mm [in] 95 [3.74]	95 [3.74]	130 [5.12]	95 [3.74]	107.5 [4.23]	130 [5.12]	162.2 [6.39]



¹Dual circuit: the 2 circuits are independent.

²: dimensions concern the valving blocks only.

	Pedal New			Vertical lever	Horizontal lever
Options			 Under development		

Accumulator charging valves



- ✓ Max. flow to auxiliary circuit: 120 L/min [32 GPM]
- ✓ Cut-in / cut-out pressure: 110 / 130 bar to 180 / 210 bar [1 600 / 1 900 to 2 611 / 3 045 PSI]
- ✓ Accumulator supply flow: 2.75 to 15 L/min [0.75 to 4.0 GPM]

VB type		VB 100			VB 200		
							
		Single-circuit			Dual-circuit		
Reference		30*	45*	120*	30*	45*	120*
Max. pressure bar [PSI]	Cut-in / Cut-out	180 / 210 [2611 / 3 045]			180 / 210 [2611 / 3 045]		
Max. flow L/min [GPM]	Auxiliary	30 [7.9]	45 [11.9]	120 [31.7]	30 [7.9]	45 [11.9]	120 [31.7]
	Accumulator	15 [3.96]			15 [3.96]		
Length	mm [in]	106 [4.17]			106 [4.17]		
Width	mm [in]	70 [2.76]			87 [3.42]		
Height	mm [in]	61 [2.40]		70 [2.76]	87.5 [3.44]		96 [3.78]

*: flow rate to auxiliaries (L/min)

Power brake valves

- ✓ Brake actuator + accumulator charging valve
- ✓ Low leaking
- ✓ Cost and space savings
- ✓

VB type		VB 110			VB 220			VB 22E	
									
		Single-circuit			Dual-circuit			Dual-circuit	
Reference		30*	45*	120*	30*	45*	120*	30*	45*
Max. pressure bar [PSI]	Cut-in/Cut-out	180 / 210 [2611 / 3 045]							
	Service	120 [1 740]							
Max. flow L/min [GPM]	Auxiliary	30 [7.9]	45 [11.9]	120 [31.7]	30 [7.9]	45 [11.9]	120 [31.7]	30 [7.9]	45 [11.9]
	Accumulator	15 [3.96]							
Length	mm [in]	60 [2.36]		70 [2.75]	60 [2.36]		70 [2.75]	60 [2.36]	
Width	mm [in]	100 [3.94]		112 [4.41]	100 [3.94]		112 [4.41]	173 [6.81]	
Height	mm [in]	95 [3.74]		95 [3.74]	95 [3.74]		95 [3.74]	135 [5.31]	

*: flow rate to auxiliaries (L/min)

To know the other values, please consult the Technical Catalogs, on our web site:
<http://www.poclain-hydraulics.com>

Documentation n°  A06604D

CIRCUIT VALVES

- ✓ High pressure
- ✓ Compact
- ✓ Operates with all products Poclain Hydraulics

Flow divider VQD

- ✓ Higher safety, performance & reliability
- ✓ For single & dual circuit
- ✓ Small and light weight

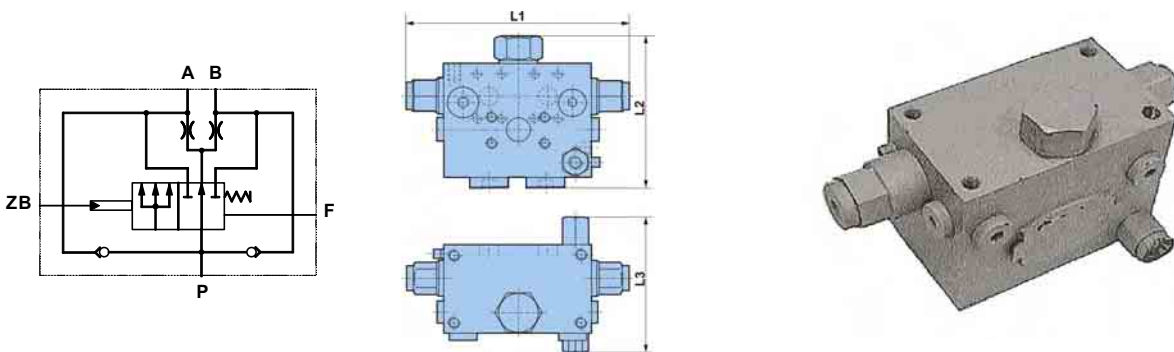

Flow divider		VQDH20
Nominal flow	L/min [GPM]	130 [34.3]
Max. pressure	bar [PSI]	450 [6 526]
L1 max.	mm [in]	272 [10.71]
L2	mm [in]	165 [6.50]
L3 max.	mm [in]	145 [5.71]
Weight	kg [lb]	14.5 [32]

High pressure directional valves VD

- ✓ Circuit bypass or cut-off

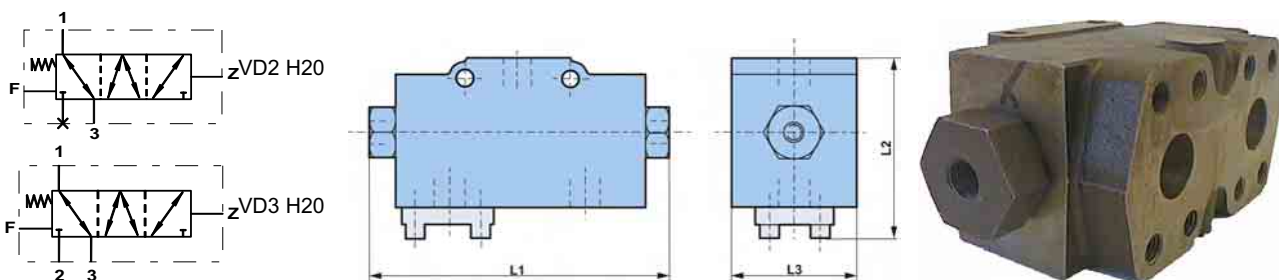

Directional valves		VD2 H20	VD2 H25	VD3 H20	VD3 H25
Function		Locking		Bypass	
Nominal flow	L/min [GPM]	130 [34.3]	260 [68.7]	130 [34.3]	260 [68.7]
Max. pressure	bar [PSI]	450 [6 526]			
L1 max.	mm [in]	188 [7.40]			
L2	mm [in]	130 [5.12]		100 [3.94]	
L3 max.	mm [in]	84 [3.31]			
Weight	kg [lb]	8 [17.5]			

Low pressure directional valves VD

- ✓ Control flow on Twin-Lock™ circuits

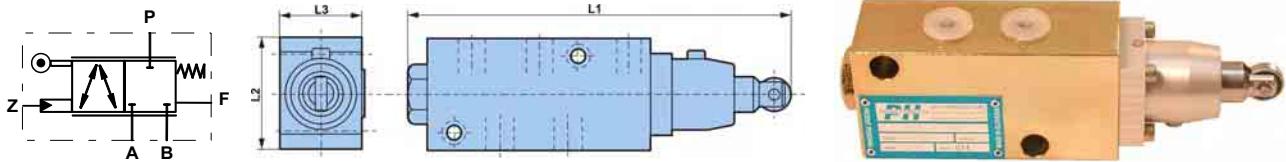

Directional valves		VD2H08
Nominal flow	L/min [GPM]	20 [5.3]
Max. pressure	bar [PSI]	450 [6 526]
L1 max.	mm [in]	214 [8.43]
L2	mm [in]	63 [2.48]
L3 max.	mm [in]	46 [1.81]
Weight	kg [lb]	2.7 [6.0]

Exchange block VM

- ✓ Send part of the flow to the cooler
- ✓ :Two versions:

- A = hot oil shuttle valve
- B = hot oil shuttle + cross-over high pressure relief valve

VME (a)		VME (b)			
				VME A	VME B
Max. pressure	bar [PSI]	420 [6 100]			
L1 max.	mm [in]	150 [5.90]	205 [8.07]		
L2	mm [in]	81 [3.11]	112.5 [4.42]		
L3 max.	mm [in]	117.5 [4.63]	128.5 [5.06]		
Weight	kg [lb]	7.8 [17.2]	11.5 [25.5]		

ELECTRO-HYDRAULIC COMPONENTS

- ✓ Designed for Poclain Hydraulics transmissions
- ✓ Compact & reliable

Traction control valves

- ✓ Restricts flow to slipping wheel motor

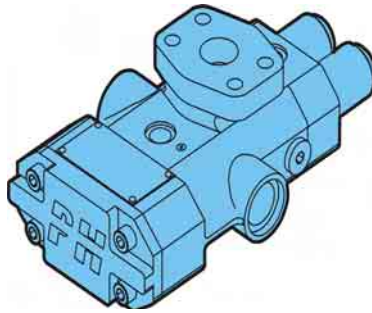

		VMA In-line model		VMA Flanged model	
		12 & 24 V DC		12 & 24 V DC	
Max. flow	L/min [GPM]	20 [5.2]	50 [13.2]	20 [5.2]	50 [13.2]
Max. pressure	bar [PSI]	450 [6 526]		450 [6 526]	
Length	mm [in]	256 [10.08]		256 [10.08]	
Width	mm [in]	134 [5.27]		150 [5.90]	
Height	mm [in]	81 [3.19]		66 [2.60]	
Weight	kg [lb]	7.2 [15.9]		11.2 [24.7]	

🇬🇧 Reference technical documentation: 801 478 146F

SMARTDRIVE™ ECU

- ✓ For self-propelled machinery
- ✓ High productivity & safety
- ✓ Smooth and comfortable driving
- ✓ Advanced functions

Four solutions:

- ✓ **SmartDrive™ Off-Road** : electronic solution for traction control systems
- ✓ **SmartDrive™ Master** : electronic solution for the management of hydrostatic transmissions
- ✓ **SmartDrive™ Premier** : electronic solution for the management of hydrostatic transmissions and for traction control systems

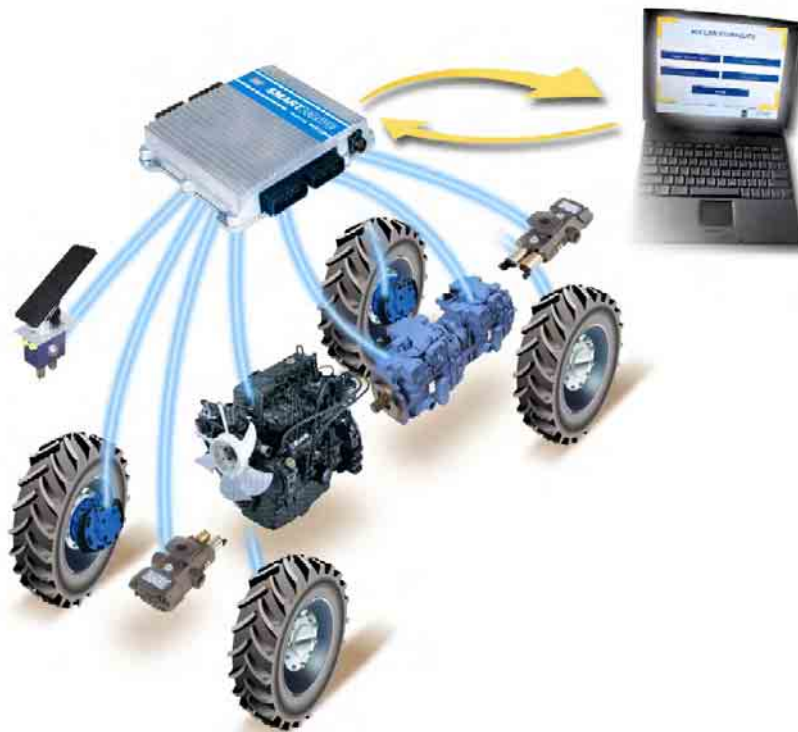

New

SmartDrive System	Off-Road™	Master™	Premier™	Easy™
Drivability		●	●	●
Management of components		●	●	●
Safety features		●	●	●
Traction control function	●		●	
Front/rear differential drive lock		●	●	
Limp mode	●	●	●	●
CAN Bus communication	●	●	●	●
*Parameter setting	●	●	●	●

*: with the PC software PHASES™ or with a HHT (hand-held terminal)

New

SmartDrive™ Easy :Do-It -Yourself solution for the management of hydrostatic transmissions

- ✓ No programming to be carried out
- ✓ An assistance in the choice of the functions
- ✓ Convivial tools on PC

The SmartDrive™ Easy is:

- ✓ Simple
- ✓ Economic
- ✓ Rapid to be implemented
- ✓ Reliable



PHASES™ PC software

- ✓ Assistant software for embedded systems
- ✓ Downloading of the on-board program
- ✓ Calibration of system components
- ✓ Changes to the configuration defining vehicle's behaviour
- ✓ Diagnostics



Services

Motors

Pumps

Circuit components

Mobile electronics



SMARTDRIVE™ CANALOGGER

✓ Canalogger

General characteristics

Description	Characteristics
Inputs	<ul style="list-style-type: none"> • 12 analog inputs • 8 temperature inputs • 8 digital inputs • 5 frequency inputs • 1 supply input • 1 CAN machine plug • 1 Hand held terminal / Debug plug
Supply voltage	10 to 30 V
Operating temperature	- 20°C to 70°C [- 4°F to 182°F]
Mass	3.85 kg [8.47 lb]
SD Canalogger protection index with its connectors	IP 65 (weather proofing)
Resistance	1m [40 inch] fall
SD Canalogger set-up	Set-up with a PC using the Canalogger Explorer™ software application or the hand held terminal with serial link
Sample frequency	<ul style="list-style-type: none"> • Up to 500 Hz for analog, frequency and digital inputs • Up to 25 Hz for temperature inputs • Up to 1 Mbit/sec for the CAN bus
Saving	Smart Media Card
Communication	Serial link RS 232

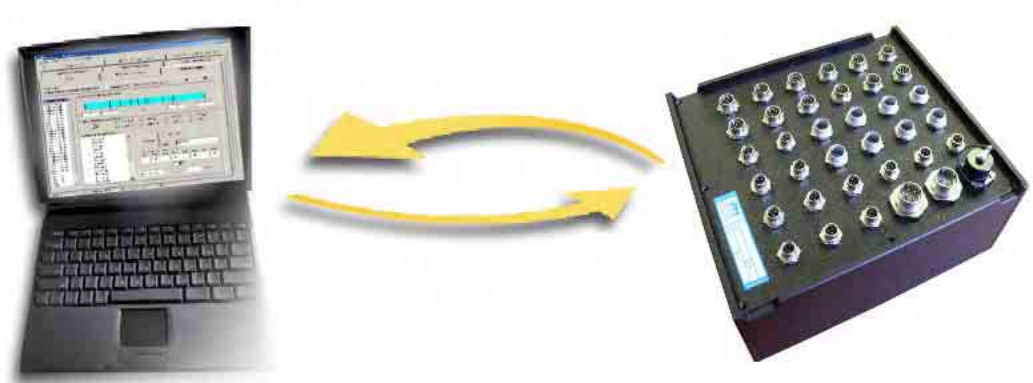

Main components

SmartDrive™ ECU: specific according to the SmartDrive type



New
SmartDrive™ Easy ECU

Joystick



160 bar [2320 PSI] pressure sensor for braking circuit

Rotary actuator: controls injection on engines



600 bar [8700 PSI] pressure sensor for the high pressure line

Rotary potentiometer: detects movement (lever position)



Pedal

Display

New



New
SmartDrive™ Canlogger and its software (Canlogger Explorer™)

Services

Motors

Pumps

Circuit components

Mobile electronics

Eleven subsidiaries and a worldwide network of more than 100 distributors and partners ...



	11/04/2007
	A02485B
	A02486C
	A02487D
	A02488E
	-
	A04513F
	A04199P
	

Poclain Hydraulics reserves the right to make any modifications it deems necessary to the products described in this document without prior notification. The information contained in this document must be confirmed by Poclain Hydraulics before any order is submitted.

Illustrations are not binding.

The Poclain Hydraulics brand is the property of Poclain Hydraulics S.A.