

Flow Controls

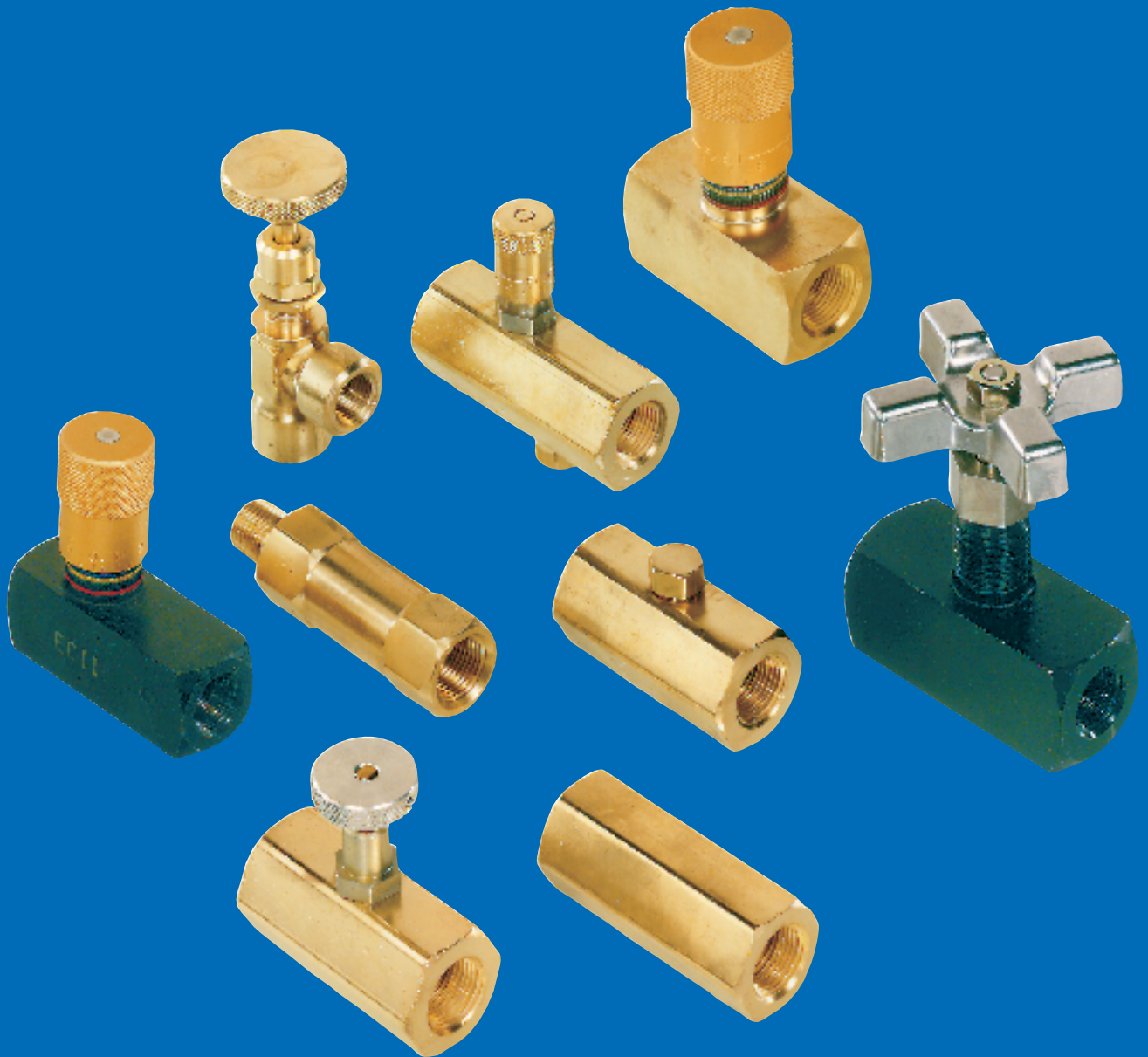

REGO® CRYO-FLOW PRODUCTS

REGO Stainless Steel Flow Controls

TMF Series with Color Bands

Designed for extremely precise control of hydraulic and pneumatic actuators. Provides metered flow in one direction and free-flow in the reverse direction. Specifically designed for use in food processing industries and other highly corrosive environments.

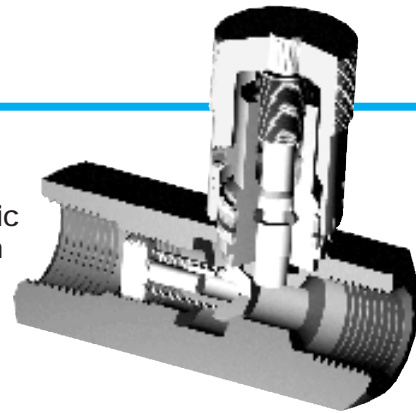

Features:

- Easy-to-read color bands and micrometer knob for exact flow settings.
- Re-set repeatability within 1%.
- Precision-machined Double-Step stem with fine threading provides accurate control, even at extremely low flows.
- Rugged, all-metal construction — no plastic parts.
- Bleed holes in piston provide a cushion to soften closing impact and extend valve life.
- Brazed construction to withstand high pressure.
- 303 stainless steel body construction for maximum corrosion protection.

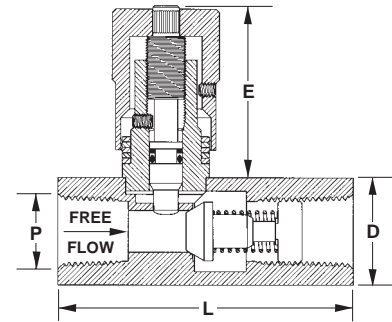

Ordering Information:

Part Number	Body Material	Piston Seal	P Female	D (In.) Square	L (In.)	E (In.) Max.	Orifice Diameter (In.)	CV (Free-Flow Direction)	CV (Controlled Flow Direction)
TMF250SS	Stainless Steel	Metal	1/4 NPT	1 3/16	2 5/8	1 3/8	5/32	1.47	.47
TMF375SS			3/8 NPT	1	2 3/4	1 23/32	7/32	2.95	.72
TMF500SS			1/2 NPT	1 1/8	3 7/16	2 1/4	5/16	4.50	1.07
TMF750SS			3/4 NPT	1 1/2	3 3/8	5/8	3/8	5.41	1.71
TMF1000SS			1 NPT	2	5	3 7/8	7/32	5.90	2.45
TMF620SS			9/16-18 SAE 6	1 3/16	3 1/8	1 3/8	5/32	1.47	.47
TMF820SS			3/4-16 SAE 8	1	3 1/2	1 23/32	7/32	2.95	.72

Specifications:

Maximum Operating Pressure	5000 PSIG
Temperature Range	-20°F to +400°F
Cracking Pressure (Check Valve)	2 PSIG
Stem Taper	2° x 45° DOUBLE-STEP
Stem Pitch	40 Threads/Inch
CV Factor	See Ordering Information

Materials:

Body	303 Stainless Steel
Piston	Stainless Steel
Piston Seal	Metal to Metal.
Spring	Stainless Steel
Stem	Stainless Steel
Knob	Nickel-Chrome Plated Brass
Color Bands	Anodized Aluminum
Piston Retainer	Stainless Steel
Set Screw	Stainless Steel
Stem Packing	Viton O-ring with "Teflon" Backup

Performance

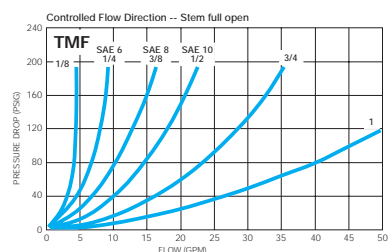
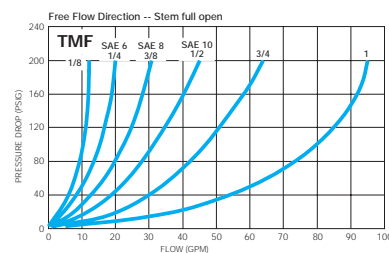

REGO CRYO-FLOW PRODUCTS

Phone: (336) 226-3244

Fax: (336) 227-6294

E-mail: cfo@regoproducts.com

Division of Engineered Controls International, Inc.

Needle Valves

TRU Micro TMN Series with Color Bands

Designed for extremely precise control of air and hydraulic fluids.

Features:

- Easy-to-read color bands and micrometer knob provide exact flow settings.
- Re-Set Repeatability within 1%.
- Precision machined DOUBLE-STEP stem with fine threading provides accurate control, even at extremely low flows.
- Rugged, all-metal construction – no plastic parts.
- Brazed construction to withstand high pressure.
- Steel valves are zinc-plated AND sealed with black chromate for double corrosion protection.
- SAE PORTS AVAILABLE, consult factory.

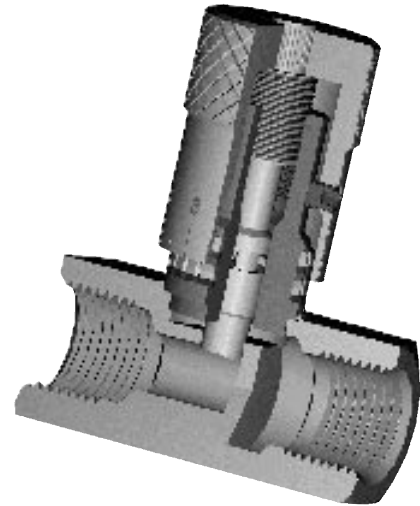

Ordering Information:

Part Number	Body Material	P (NPT) Female	D (In.) Square	L (In.)	E (In.) Max.	Orifice Diameter (In.)	CV
TMN125B	Brass	1/8	5/8	1 1/2	1 7/32	1/8	.25
TMN250B		1/4	13/16	2	1 3/8	5/32	.47
TMN375B		3/8	1	2 1/2	1 23/32	7/32	.72
TMN500B		1/2	1 1/8	2 5/8	2 1/2	5/16	1.07
TMN250S	Steel	1/4	13/16	2	1 3/8	5/32	.47
TMN375S		3/8	1	2 1/2	1 23/32	7/32	.72
TMN500S		1/2	1 1/8	2 5/8	2 1/4	5/16	1.07
TMN750S		3/4	1 1/2	3 1/4	2 15/32	3/8	1.71
TMN1000S		1	2	4 1/4	3 7/8	5/8	2.45

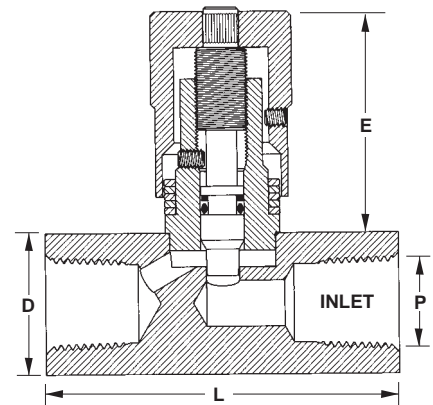

Specifications:

Maximum Operating Pressure	5000 PSIG Steel 2000 PSIG Brass
Temperature Range	-20°F to +400°F
Stem Taper	2° x 45° DOUBLE-STEP
Stem Pitch	40 Threads/Inch
CV Factor	See Ordering Information

Materials:

Body	12L14 Steel or ASTM B 16 Brass
Stem	Stainless Steel
Knob	Brass
Color Bands	Anodized Aluminum
Set Screw	Steel
Stem Packing	Viton O-ring with "Teflon" Backup

Performance

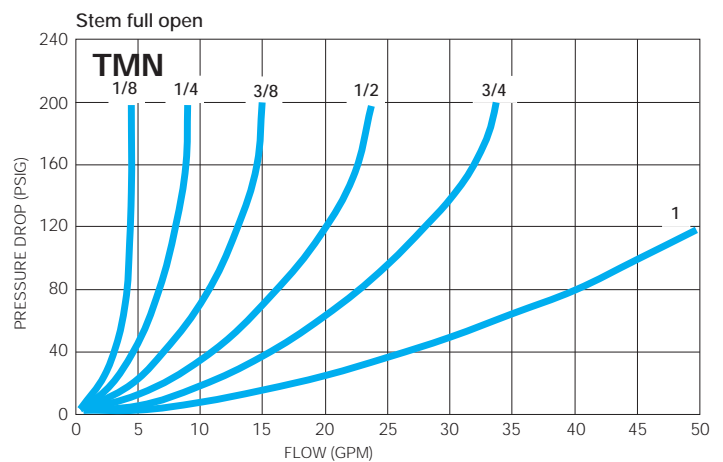

Needle Valves

MN Series

The best value for precise control of air and hydraulic fluids where a calibrated knob is required.

Features:

- Precision-machined long tapered stem with fine threading provides exact control.
- Calibrated knob provides setting reference and does not drift from setting.
- Durability provided by rugged, all metal construction with no plastic parts.
- Steel valves are zinc-plated and sealed with “golden glow” chromate for double corrosion protection.

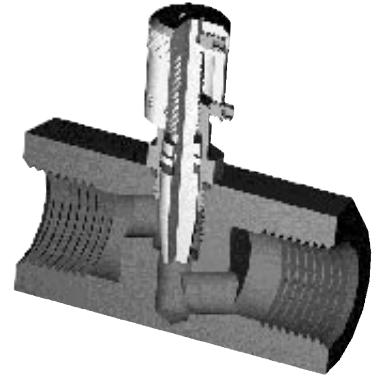

Ordering Information:

Part Number	Body Material	P (NPT) Female	D (In.) Hex	L (In.)	E (In.) Max.	Orifice Diameter (In.)	CV	
MN125B	Brass	1/8	1 1/16	1 1/2	1 1/4	.156	.25	
MN250B		1/4	7/8	2			.39	
MN375B		3/8	1 1/16	2 1/4	1 3/8		.265	.93
MN500B		1/2	1 5/16	2 21/32			.281	1.12
MN250S	Steel	1/4	7/8	2	1 1/4	.156	.39	
MN375S		3/8	1 1/16	2 1/4	1 3/8	.265	.93	
MN500S		1/2	1 5/16	2 21/32		.281	1.12	
MN750S		3/4	1 5/8	3	1 1/4	.343	2.00	
MN1000S		1	1 7/8	3	2 1/8	.343	2.00	

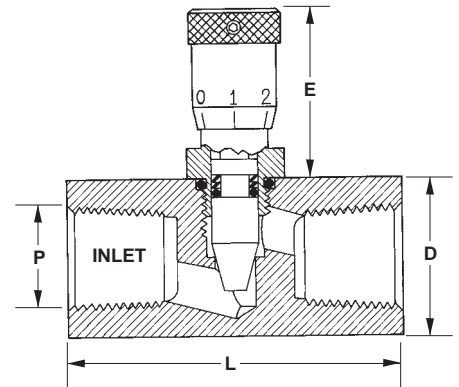

Specifications:

Maximum Operating Pressure	5000 PSIG Steel 2000 PSIG Brass
Temperature Range	-20°F to +212°F
Stem Taper	8°
Stem Pitch	40 Threads/Inch
CV Factor	See Ordering Information

Materials:

Body	12L14 Steel or ASTM B 16 Brass
Stem	Stainless Steel or Brass
Knob	Brass
Chamber	Steel
Set Screw	Steel
Stem Packing	Viton with “Teflon” Backup

Performance

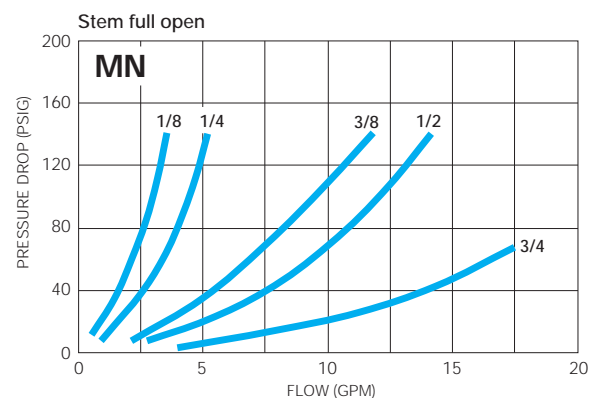

Needle Valves

KLN Series

Designed for the precise control of air and hydraulic fluids.

Features:

- Precision-machined long tapered stem with fine threading provides exact control.
- Lock nut provided to secure flow settings.
- Durability provided by rugged, all metal construction with no plastic parts.
- Steel valves are zinc plated and sealed with "golden glow" chromate for double corrosion protection.

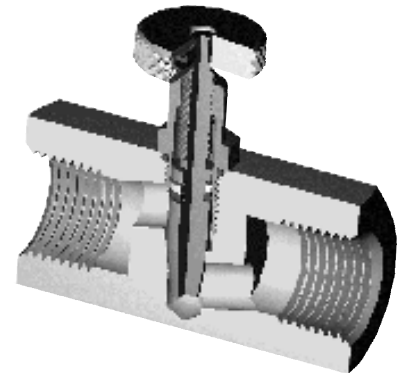

Ordering Information:

Part Number	Body Material	P (NPT) Female	D (In.) Hex	L (In.)	E (In.) Max.	Orifice Diameter (In.)	CV
KLN125B	Brass	1/8	1 1/16	1 1/2	1 1/4	.156	.25
KLN250B		1/4	7/8	2			
KLN375B		3/8	1 1/16	2 1/4	1 3/8	.265	.93
KLN500B		1/2	1 5/16	2 2 1/32			
KLN750B		3/4	1 5/8	3	1 7/8	.343	2.00
KLN1000B		1	1 7/8				
KLN125S	Steel	1/8	1 1/16	1 1/2	1 1/4	.156	.25
KLN250S		1/4	7/8	2			
KLN375S		3/8	1 1/16	2 1/4	1 3/8	.265	.93
KLN500S		1/2	1 5/16	2 2 1/32			
KLN750S		3/4	1 5/8	3	1 7/8	.343	2.00
KLN1000S		1	1 7/8				

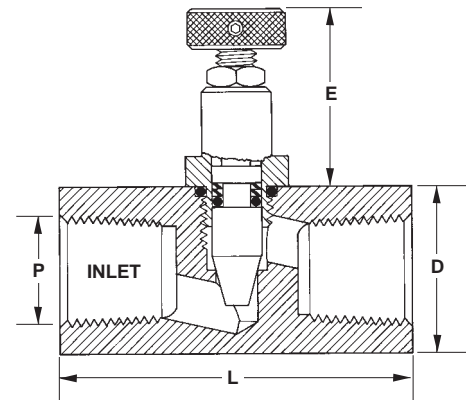

Specifications:

Maximum Operating Pressure	5000 PSIG Steel 2000 PSIG Brass
Temperature Range	-20°F to +212°F
Stem Taper	8°
Stem Pitch	40 Threads/Inch (1/8, 1/4, 3/8, 1/2" Sizes) 24 Threads/Inch (3/4, 1" Sizes)
CV Factor	See Ordering Information

Materials:

Body	12L14 Steel, ASTM B 16 Brass, or 303 Stainless Steel
Stem	Stainless Steel or Brass
Knob	Aluminum (1/8, 1/4, 3/8, 1/2" Sizes) Brass (3/4, 1" Sizes)
Chamber	Steel (zinc plated)
Lock Nut	Brass
Stem Packing	Viton O-ring with "Teflon" Backup

Performance

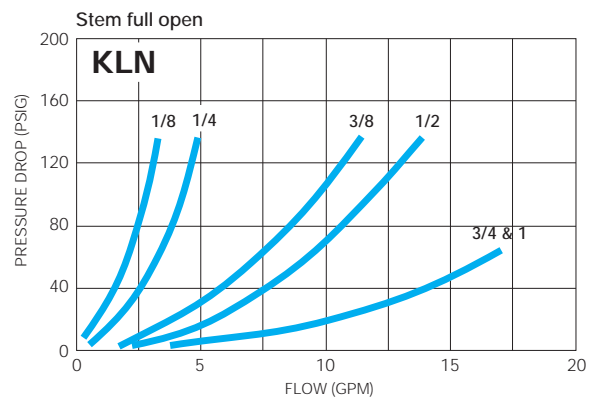

Needle Valves

N Series

Economically designed for effective control of air and hydraulic fluids where frequent adjustment is not required.

Features:

- Wrench flats provided to adjust setting, while resisting unwanted tampering.
- Steel valves are zinc plated and sealed with “golden glow” chromate for double corrosion protection.
- Durable, rugged, all metal construction — no plastic parts.

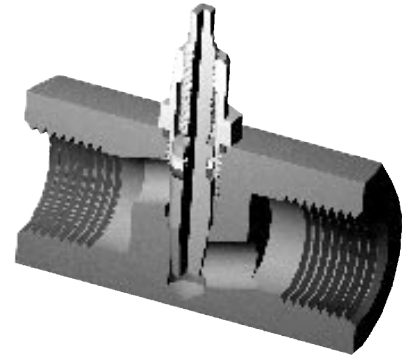

Ordering Information:

Part Number	Body Material	P (NPT) Female	D (In.) Hex	L (In.)	E (In.) Max.	Orifice Diameter (In.)	CV
N125B	Brass	1/8	1 1/16	1 1/2	1 1/4	.156	.25
N250B		1/4	7/8	2			
N375B		3/8	1 1/16	2 1/4	1 3/8	.265	.93
N500B		1/2	1 5/16	2 21/32			
N250S	Steel	1/4	7/8	2	1 1/4	.156	.39
N375S		3/8	1 1/16	2 1/4			
N500S		1/2	1 5/16	2 21/32	1 3/8	.281	1.12

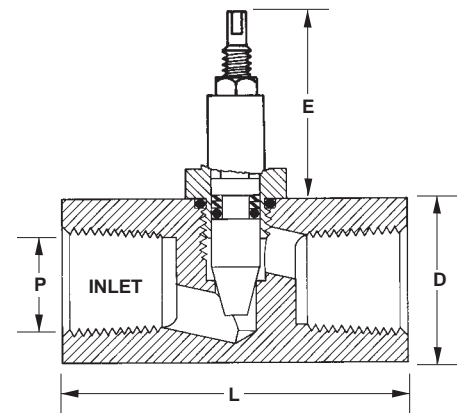

Specifications:

Maximum Operating Pressure	5000 PSIG Steel 2000 PSIG Brass
Temperature Range	-20°F to +212°F
CV Factor	See Ordering Information
Stem Taper	8°
Stem Pitch	40 Threads/Inch

Materials:

Body	12L14 Steel or ASTM B 16 Brass
Stem	Stainless Steel or Brass
Chamber	Steel (Zinc Plated)
Lock Nut	Brass
Stem Packing	Viton O-Ring

Performance

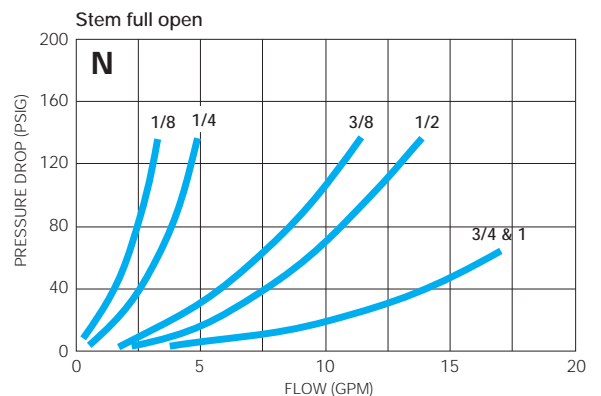

Needle Valves

Mini-Line Series

Ideal for test bench and control panel applications. Designed for use with air, oil, water, steam, vacuum service, and most chemicals.

Features:

- Compact design provides easy installation.
- Fine stem threading and long taper allow precise metering and leak-free shut-off.
- Internal stop prevents the stem from being accidentally unscrewed from the body.
- Rugged forged brass bodies withstand higher pressures.
- Available in globe and angle configurations.
- Valves come equipped for panel mounting.
- Some models available with stainless steel stem (ss suffix denotation).

Ordering Information:

NVA

Part Number	A (NPT)	B (UNS-2B) Thd. Size	C (In.) Hex Size	D (In.) Max.	E (In.)	F (In.)	G (In.)	H (In.)	I (In.)	J (In.) Open	J (In.) Closed	CV
NVA125B	1/8	1/2 - 27	1 1/16	3/32	1 1/4	1 5/32	3/4	3/4	7/16	1 3/32	1 11/16	.7
NVA250B	1/4			7/32		1	1	2 5/32		1 19/32		

MMA

Part Number	A (NPT)	B (UNS-2B) Thd. Size	C (In.) Hex Size	D (In.) Max.	E (In.)	F (In.)	G (In.)	H (In.)	I (In.)	J (In.) Open	J (In.) Closed	CV
MMA250B	1/4	1/2 - 27	1 1/16	7/32	1 1/4	1 11/32	1	1	7/16	2 5/32	1 19/32	.7
HHA250B	1/4*	1/2 - 27	1 1/16	7/32	1 1/4	1 11/32	1	1	7/16	2 5/32	1 19/32	.7

*1/4" Hose Barbs

MFA

Part Number	A (NPT)	B (UNS-2B) Thd. Size	C (In.) Hex Size	D (In.) Max.	E (In.)	F (In.)	G (In.)	H (In.)	I (In.)	J (In.) Open	J (In.) Closed	CV
MFA125B	1/8	1/2 - 27	1 1/16	7/32	1 1/4	1 7/32	7/8	7/8	7/16	2 5/32	1 19/32	.7
MFA250B	1/4					1 11/32	1	1				
MFA250BSS												

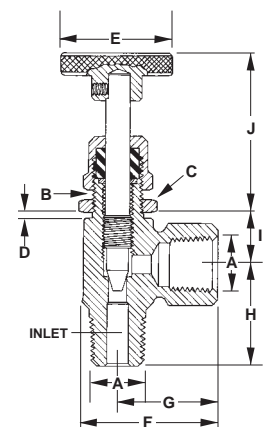
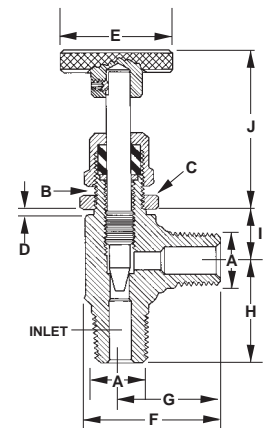
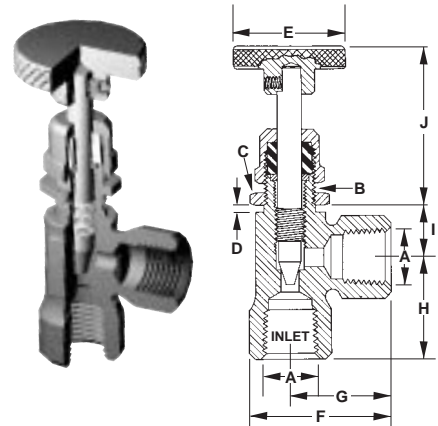

Needle Valves

Mini-Line Series

NVG

Part Number	A (NPT)	B (UNS-2B) Thd. Size	C (In.) Hex Size	D (In.) Max.	E (In.)	F (In.)	G (In.)	H (In.)	I (In.)	J (In.) Open	J (In.) Closed	CV
NVG125B	1/8	1/2 - 27	1 1/16	7/32	1 1/4	1 7/8	15/16	13/32	7/16	2 5/32	1 25/32	.5
NVG250B	2					1						
NVG250BSS	2					1						

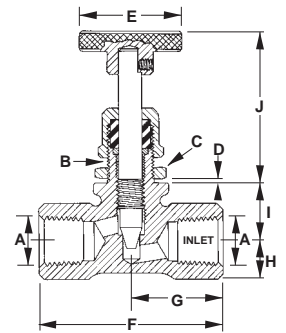

MFG

Part Number	A (NPT)	B (UNS-2B) Thd. Size	C (In.) Hex Size	D (In.) Max.	E (In.)	F (In.)	G (In.)	H (In.)	I (In.)	J (In.) Open	J (In.) Closed	CV
MFG125BF	1/8	1/2 - 27	1 1/16	7/32	1 1/4	1 7/8	15/16	13/32	7/16	2 5/32	1 25/32	.5
MFG250BF	2					1						

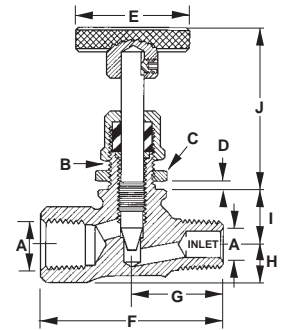

Specifications:

Maximum Operating Pressure	5000 PSIG Hydraulic 2000 PSIG Air
Minimum Burst Pressure	8000 PSIG
Temperature Range	-40°F to +500°F
Orifice Diameter	.182"
Stem Taper	15°
Stem Pitch	28 Threads/Inch
CV Factor	See Ordering Information

Materials:

Body	ASTM B283 Brass
Stem	Brass
Knob	Brass
Bonnet Nut	Brass
Panel Mount Nut	Brass
Set Screw	Steel
Stem Packing	Teflon with Brass Gland

Performance

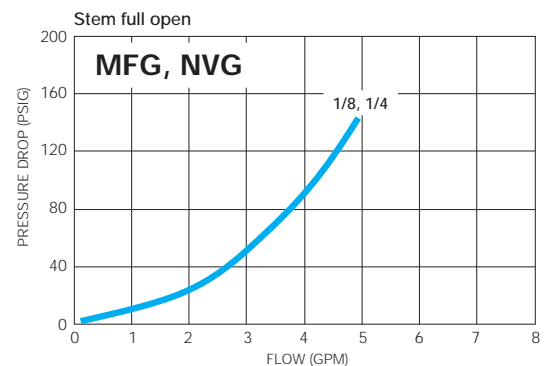
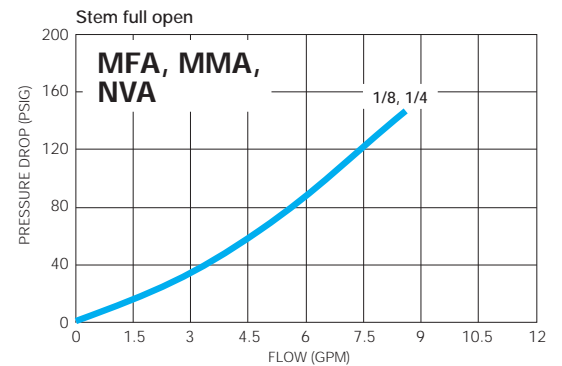

Needle Valves

2000 Series

Ideal for applications which require fine metering and shut-off. Designed for use with air, oil, water, steam, liquid fuels and most chemicals.

Features:

- Heavy duty brazed construction for added strength and safety up to 10,000 psi.
- Precision-machined stems and valve bodies provide perfect seat alignment for leak-free shut-off.
- Carbon steel valves are zinc plated and sealed with black chromate for double corrosion protection.
- Available in globe and angle configuration; in-line or panel mounted.
- Machined from carbon steel, or 303 stainless steel.

Ordering Information:

FFG

Part Number	Body Material	A (NPT) Female	B (In.) Max.	C (In.)	D (In.)	E (In.)	F (In.) Square	G (In.)	H (In.) Diam.	Orifice Diam. (In.)	CV
FFG2001T	Carbon Steel	1/8	3 1/2	3 1/32	1 15/16	2 1/2	7/8	3/8	5/8	7/22	.66
FFG2002T		1/4		1 1/32	2 1/16				7/8		
FFG2003T		3/8	3 5/8	1 7/16	2 3/4		1 1/8		3/4	7/16	.70
FFG2004T		1/2									
FFG2006TA		3/4	5 3/16	1 13/16	3 5/8	4 1/4	1 1/2	7/8	1 1/2	9/16	3.90
FFG2008TA		1	5 5/16	2 1/32	4 1/16	2	1 1/2	7/8	1 1/2	9/16	5.22
FFG2002SST	303 Stainless Steel	1/4	3 1/2	1 1/32	2 1/16	2 1/2	7/8	3/8	5/8	7/32	.66
FFG2003SST		3/8		1 7/16	2 3/4				7/8		
FFG2004SST		1/2	3 5/8	1 7/16	2 3/4		1 1/8		3/4	7/16	.70
FFG2006SSTA		3/4				5 3/16		1 13/16			
FFG2008SSTA		1	5 5/16	2 1/32	4 1/16	2	1 1/2	7/8	1 1/2	9/16	5.22

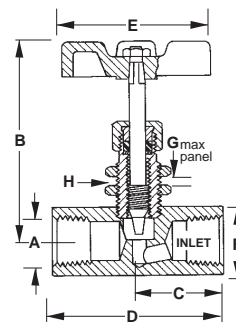
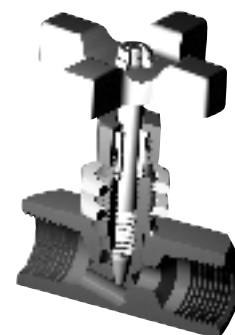

MFG

Part Number	Body Material	A (NPT) Male x Female	B (In.) Max.	C (In.)	D (In.)	E (In.)	F (In.) Square	G (In.)	H (In.) Diam.	Orifice Diam. (In.)	CV
MFG2002T	Carbon Steel	1/4	3 1/2	1 1/32	2 11/32	2 1/2	7/8	3/8	5/8	.218	1.10
MFG2003T		3/8		1 3/8	2 3/4				7/8		
MFG2004T		1/2	2 5/8	2 5/8	1 1/8		3/4		7/16	7/16	

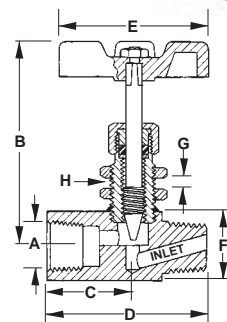

Needle Valves

2000 Series

FFA

Part Number	Body Material	A (NPT Female)	B (In.) Max.	C (In.)	D (In.)	E (In.)	F (In.) Square	G (In.)	H (In.) Diam.	I (In.)	Orifice Diam. (In.)	CV
FFA2001T	Carbon Steel	1/8	3 1/2	1	1 1/2	2 1/2	1	3/8	5/8	1 1/16	7/32	.92
FFA2002T		1/4		1 9/32	1 25/32		1		1 1/4			
FFA2003T		3/8	3 5/8	1 17/32	2 5/32	1 1/4	3/4	1 19/32	9/16	4.43		
FFA2004T		1/2	5 7/16	1 27/32	2 23/32	4 1/4	1 3/4	7/8	1 1/2	1 15/16	7/32	
FFA2006TA		3/4	1 9/32	1 25/32	2 1/2	1	3/8	5/8	1 1/16	7/32	.92	
FFA2002SST	303 Stainless Steel	1/4	3 1/2	1 9/32	1 25/32	2 1/2	1	3/8	5/8	1 1/16	7/32	.92

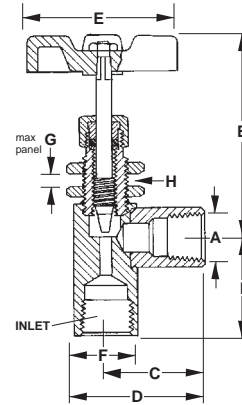

MFA

Part Number	Body Material	A (NPT Male x Female)	B (In.) Max.	C (In.)	D (In.)	E (In.)	F (In.) Square	G (In.)	H (In.) Diam.	I (In.)	Orifice Diam. (In.)	CV
MFA2002T	Carbon Steel	1/4	3 1/2	1 9/32	1 25/32	2 1/2	1	3/8	5/8	1 1/16	7/32	.92
MFA2003T		3/8	3 5/8	1 17/32	2 5/32		1 1/4		3/4	1 3/4		
MFA2004T		1/2	5 7/16	1 27/32	2 23/32		4 1/4		1 3/4	7/8		1 1/2

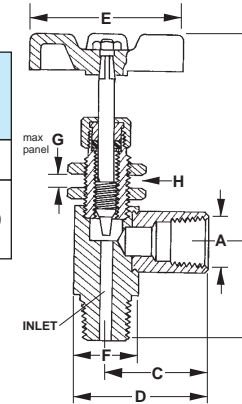

Specifications:

Maximum Operating Pressure	10,000 PSIG Hydraulic 2000 PSIG Air
Minimum Burst Pressure	20,000 PSIG
Temperature Range	-40°F to +500°F
Stem Taper	10 1/2° (1/8, 1/4, 3/8, 1/2" Sizes) 15° (3/4, 1" Sizes)
Stem Pitch	16 Threads/Inch (1/8, 1/4, 3/8, 1/2" Sizes) 14 Threads/Inch (3/4, 1" Sizes)
CV Factor	See Ordering Information

Performance

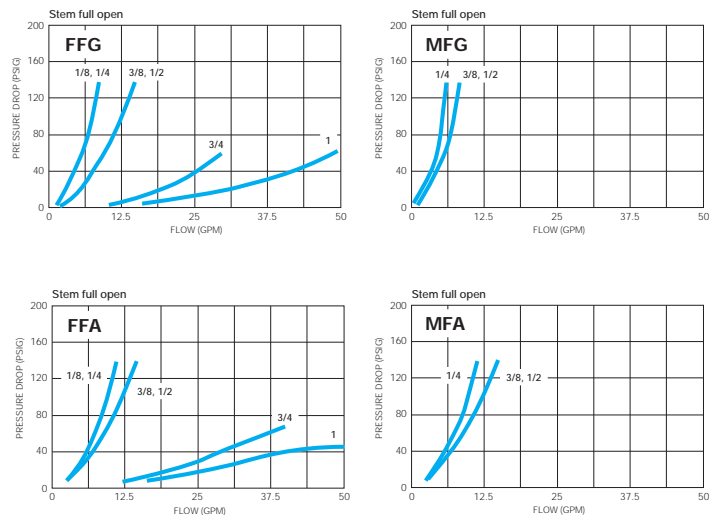

Materials:

	T and TA Models	SST and STA Models
Body	12L14 Carbon Steel	303 Stainless
Stem	303 Stainless	303 Stainless
Bonnet Nut	Carbon Steel	303 Stainless
Handle	Aluminum	Aluminum
Stem Packing	Teflon	Teflon

Panel Mounting Kits:

Valve Size	Kit Number
1/8 to 1/4	KIT2002S
3/8 to 1/2	KIT2004S
3/4 to 1	KIT2005S

Flow Controls

TRU Micro TMF Series with Color Bands

Designed for extremely precise control of hydraulic and pneumatic actuators. Provides metered flow in one direction and free-flow in the reverse direction.

Features:

- Easy-to-read color bands and micrometer knob for exact flow settings.
- Re-set repeatability within 1%.
- Precision-machined Double-Step stem with fine threading provides accurate control, even at extremely low flows.
- Rugged, all-metal construction — no plastic parts.
- Bleed holes in piston provide a cushion to soften closing impact and extend valve life.
- Brazed construction to withstand high pressure.
- Soft-seat piston check, available on 1/4 and 3/8" brass sizes, assures leak-free air service. All others have metal to metal seat.
- Steel valves are zinc-plated AND sealed with black chromate for double corrosion protection. Also available with stainless steel body

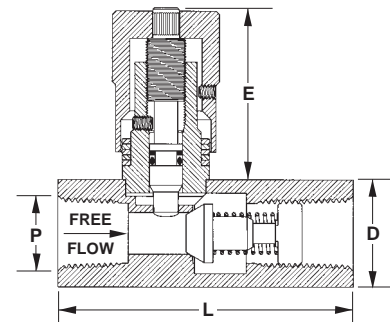
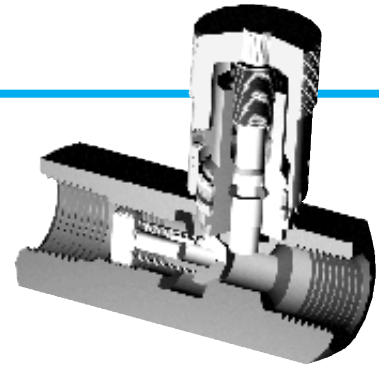

Ordering Information:

Part Number	Body Material	Piston Seal	P Female	D (In.) Square	L (In.)	E (In.) Max.	Orifice Diameter (In.)	CV (Free-Flow Direction)	CV (Controlled Flow Direction)
TMF250B	Brass	Metal	1/4 NPT	13/16	2 5/8	1 3/8	5/32	1.47	.47
TMF250BL		Viton							
TMF375B		Metal	3/8 NPT	1	2 3/4	1 23/32	7/32	2.95	.72
TMF375BL		Viton							
TMF500B	Steel	Metal	1/2 NPT	1 1/8	3 7/16	2 1/4	5/16	4.50	1.07
TMF750B			3/4 NPT	1 1/2	3 7/8	2 19/32	3/8	5.41	1.71
TMF250S			1/4 NPT	13/16	2 5/8	1 3/8	5/32	1.47	.47
TMF375S	Steel	Metal	3/8 NPT	1	2 3/4	1 23/32	7/32	2.95	.72
TMF500S			1/2 NPT	1 1/8	3 7/16	2 1/4	5/16	4.50	1.07
TMF620S			7/16-18 SAE 6	13/16	3 3/8	1 3/8	5/32	1.47	.47
TMF750S			3/4 NPT	1 1/2	3 7/8	2 19/32	3/8	5.41	1.71
TMF820S			3/4-16 SAE 8	1	3 1/2	1 23/32	7/32	2.95	.72
TMF1000S			1 NPT	2	5	3 7/8	5/8	5.90	2.45
TMF1020S			7/8-14 SAE 10	1 1/8	4	2 1/4	5/16	4.50	1.07

*For Stainless Steel Body use SS Suffix (IE TMF500SS)

Specifications:

Maximum Operating Pressure	5000 PSIG Steel 2000 PSIG Brass
Temperature Range	-20°F to +400°F
Cracking Pressure (Check Valve)	2 PSIG
Stem Taper	2° x 45° DOUBLE-STEP
Stem Pitch	40 Threads/Inch
CV Factor	See Ordering Information

Materials:

Body	12L14 Steel or ASTM B 16 Brass
Piston	Stainless Steel
Piston Seal	Viton on 1/4 and 3/8" Brass Models with soft seat option. (Metal to Metal seal on all others).
Spring	Stainless Steel
Stem	Stainless Steel
Knob	Brass
Color Bands	Anodized Aluminum
Piston Retainer	Stainless Steel
Set Screw	Steel (Black Oxide)
Stem Packing	Viton O-ring with "Teflon" Backup

Performance

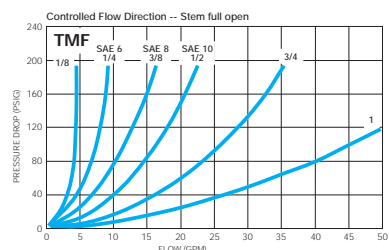
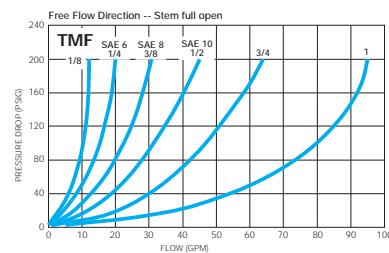

MF Series

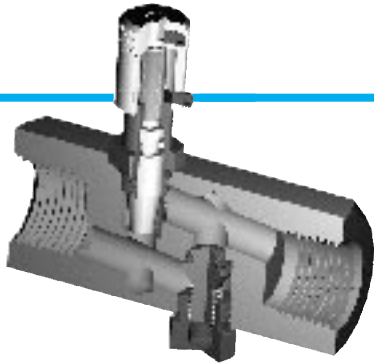

The best valve for precise control of hydraulic and pneumatic actuators where a calibrated knob is required. Provides metered flow in one direction and free-flow in the reverse direction.

Features:

- Precision-machined long tapered stem with fine threading provides exact control.
- Calibrated knob provides setting reference.
- Soft-seat piston check for leak-free service.
- No "draft" setting.
- Optional ball check for high cycle applications.
- Rugged, all-metal construction — no plastic parts.
- Steel valves are zinc-plated and sealed with "golden glow" chromate for double corrosion protection.

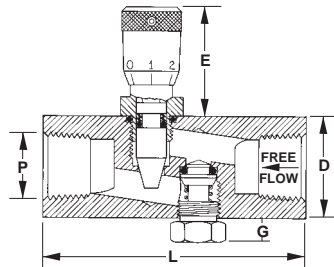

Ordering Information:

Part Number	Body Material	Check Style	P (NPT) Female	D (In.) Hex	G (In.)	L (In.)	E (In.) Max.	Orifice Diameter (In.)	CV Free-Flow Direction	CV (Controlled Flow Direction)	Cracking Pressure (PSIG)
MF125B	Brass	Piston	1/8	1 1/16	9/32	1 3/4	1 1/4	.156	.32	.23	10
MF250B			1/4	7/8	5/16	2 3/8					
MF375B			3/8	1 1/16	1 1/32	2 3/4	1 3/8	.265	1.14	.90	8
MF500B			1/2	1 5/16	3/8	3 3/16					
MF750B			3/4	1 5/8	1 5/32	3 9/16					
MF125BBC	Brass	Ball	1/8	1 1/16	9/32	1 3/4	1 1/4	.156	.32	.23	11
MF250BBC			1/4	7/8	5/16	2 3/8					
MF375BBC			3/8	1 1/16	1 1/32	2 3/4	1 3/8	.265	1.14	.90	3
MF500BBC			1/2	1 5/16	3/8	3 3/16					
MF250SBC	Steel	Ball	1/4	7/8	5/16	2 3/8	1 1/4	.156	.70	.44	7
MF375SBC			3/8	1 1/16	1 1/32	2 3/4					
MF500SBC			1/2	1 5/16	3/8	3 3/16	1 3/8	.265	1.14	.90	3
MF750SBC			3/4	1 5/8	3/8	3 3/16					
MF1000SBC			1	1 7/8	1 5/32	3 9/16					

Specifications:

Maximum Operating Pressure	
Ball Check Models	5000 PSIG Steel 2000 PSIG Brass
Piston Check Models	2000 PSIG Brass
Temperature	-20°F to +212°F
Stem Taper	8°
Stem Pitch	40 Threads/Inch (1/8, 1/4, 3/8, 1/2" Sizes) 24 Threads/Inch (3/4", 1" Size)
CV Factor	See Ordering Information

Materials:

Body	12L14 Steel or ASTM B 16 Brass
Piston Assembly	Stainless Steel with Viton O-ring
Spring	Stainless Steel
Stem	Stainless Steel or Brass
Knob	Brass
Check Plug	Steel or Brass
Chamber	Steel
Set Screw	Steel
Stem Packing	Viton O-ring with "Teflon" Backup

Performance

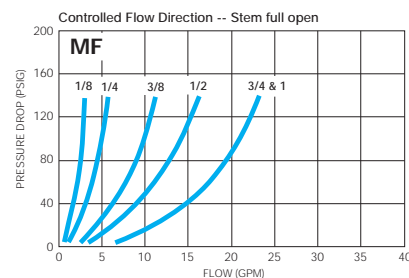
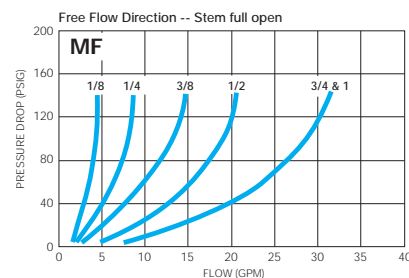

Flow Controls

KLF Series

Designed for the precise control of hydraulic and pneumatic actuators. Provides metered flow in one direction and free-flow in the reverse direction.

Features:

- Precision-machined long tapered stem with fine threading provides exact control.
- Lock nut included to secure flow setting.
- Soft-seat piston check for leak-free service.
- Ball check option available for high cycle applications.
- Rugged, all-metal construction — no plastic parts.
- Steel valves are zinc-plated and sealed with "golden glow" chromate for double corrosion protection.

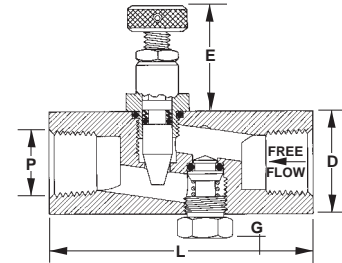
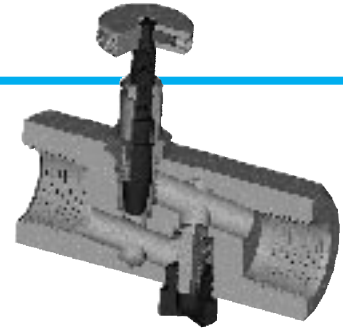

Ordering Information:

Part Number	Body Material	Check Style	P (NPT) Female	D (In.) Hex	G (In.)	L (In.)	E (In.) Max.	Orifice Diameter (In.)	CV Free-Flow Direction	CV (Controlled Flow Direction)	Cracking Pressure (PSIG)
KLF125B	Brass	Piston	1/8	1 1/16	9/32	1 3/4	1 1/4	.156	.32	.23	10
KLF250B			1/4	7/8	5/16	2 3/8					
KLF375B			3/8	1 1/16	11/32	2 3/4	1 3/8	.265	1.14	.90	8
KLF500B			1/2	1 5/16	3/8	3 3/16					
KLF750B			3/4	1 5/8	15/32	3 9/16					
KLF1000B			1	1 7/8	15/32	3 9/16	1 7/8	.343	2.91	2.02	2
KLF125BBC	Steel	Ball Check	1/8	1 1/16	9/32	1 3/4	1 1/4	.156	.32	.23	11
KLF250BBC			1/4	7/8	5/16	2 3/8					
KLF375BBC			3/8	1 1/16	11/32	2 3/4	1 3/8	.265	1.14	.90	3
KLF500BBC			1/2	1 5/16	3/8	3 3/16					
KLF750BBC			3/4	1 5/8	15/32	3 9/16					
KLF125SBC			Steel	Ball Check	1/8	1 1/16	9/32	1 3/4	1 1/4	.156	.32
KLF250SBC	1/4	7/8			5/16	2 3/8					
KLF375SBC	3/8	1 1/16			11/32	2 3/4	1 3/8	.265	1.14	.90	3
KLF500SBC	1/2	1 5/16			3/8	3 3/16					
KLF750SBC	3/4	1 5/8			15/32	3 9/16					

Specifications:

Maximum Operating Pressure	5000 PSIG Steel 2000 PSIG Brass
Ball Check Models	2000 PSIG Brass
Piston Check Models	2000 PSIG Brass
Temperature Range	-20°F to +212°F
CV Factor	See Ordering Information
Stem Taper	8°
Stem Pitch	40 Threads/Inch (1/8, 1/4, 3/8, 1/2" Sizes) 24 Threads/Inch (3/4, 1" Sizes)

Materials:

Body	12L14 Steel, ASTM B 16 Brass, or 303 Stainless Steel
Piston Assembly	Stainless Steel with Viton O-ring
Ball	Stainless Steel
Spring	Stainless Steel
Stem	Stainless Steel or Brass
Knob	Aluminum (1/8, 1/4, 3/8, 1/2" Sizes) Brass (3/4, 1" Sizes)
Check Plug	Steel or Brass
Chamber	Steel
Set Screw	Steel (Black Oxide)
Stem Packing	Viton O-ring with "Teflon" Backup
Lock Nut	Brass

Performance

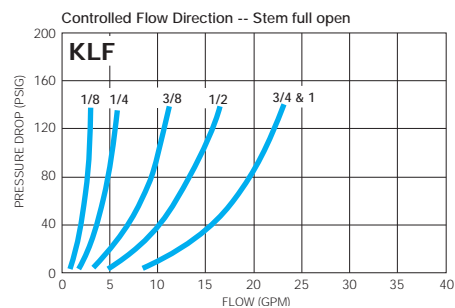
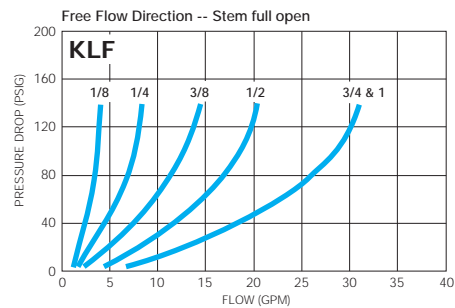

Economically designed for effective control of hydraulic and pneumatic actuators where frequent adjustment is not required.

Features:

- Soft-seat piston check for leak-free service.
- Optional ball check for high cycle applications.
- Wrench flats provided to adjust setting, while resisting unwanted tampering.
- Steel valves are zinc plated and sealed with "golden glow" chromate for double corrosion protection.

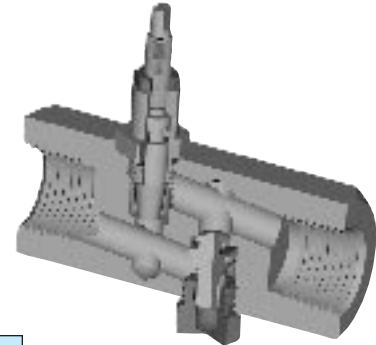

Ordering Information:

Part Number	Body Material	Check Style	P (NPT Female)	D (In.) Hex	G (In.)	L (In.)	E (In.) Max.	Orifice Diam. (In.)	CV (Free-Flow Direction)	CV (Controlled Flow Direction)	Cracking Pressure (PSIG)
F125B	Brass	Piston	1/8	1 1/16	9/32	1 3/4	1 1/4	.156	.32	.23	10
F250B			1/4	7/8	5/16	2 3/8		.70	.44	7	
F375B			3/8	1 1/16	11/32	2 3/4		.265	1.14	.90	8
F500B			1/2	1 5/16	3/8	3 3/16		.281	1.74	1.32	5
F250BBC	Steel	Ball Check	1/4	7/8	5/16	2 3/8	1 1/4	.156	.70	.44	7
F375BBC			3/8	1 1/16	11/32	2 3/4		.265	1.14	.90	3
F500BBC			1/2	1 5/16	3/8	3 3/16		.281	1.74	1.32	1
F250SBC			1/4	7/8	5/16	2 3/8		1 3/8	.156	.70	.44
F375SBC	3/8	1 1/16	11/32	2 3/4	.265	1.14	.90		3		
F500SBC	1/2	1 5/16	3/8	3 3/16	.281	1.74	1.32		1		
F750SBC	3/4	1 5/8	15/32	3 9/16	.343	2.91	2.02		3		

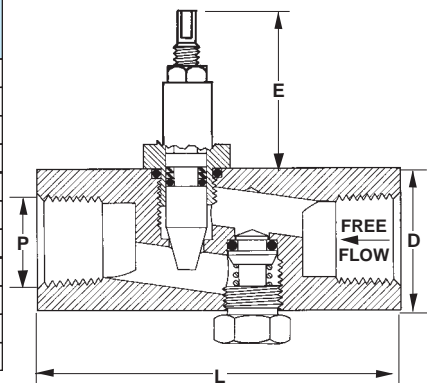

Specifications:

Maximum Operating Pressure	
Ball Check Models	5000 PSIG Steel 2000 PSIG Brass
Piston Check Models	2000 PSIG Brass
Temperature Range	-20°F to +212°F
CV Factor	See Ordering Information
Stem Taper	8°
Stem Pitch	40 Threads/Inch (1/8, 1/4, 3/8, 1/2" Sizes) 24 Threads/Inch (3/4" Size)

Materials:

Body	12L14 Steel or ASTM B 16 Brass
Piston Assembly	Stainless Steel with Viton O-Ring
Ball	Stainless Steel
Spring	Stainless Steel
Stem	Stainless Steel or Brass
Check Plug	Steel or Brass
Lock Nut	Brass
Stem Packing	Viton O-ring with "Teflon" Backup Gland
Chamber	Steel

Performance

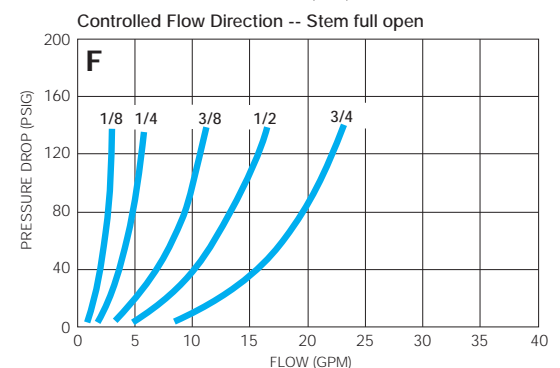
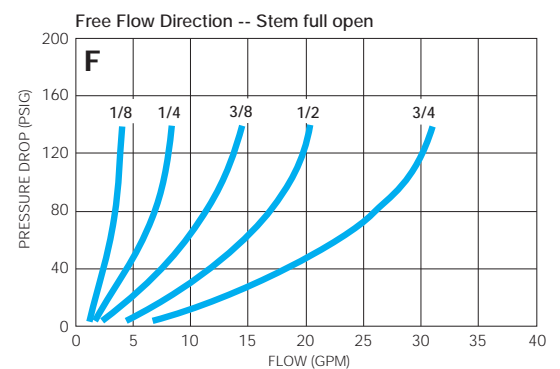

Check Valves

C-Series

Especially designed for the control of hydraulic and pneumatic systems. Allows full-flow in one direction only.

Features:

- Efficient in line design provides high flow capability with low pressure drop.
- Soft seat poppet assures leak free service. Durable all metal poppets standard on all other models.
- Steel valves are zinc plated with "golden glow" chromate for double corrosion protection.
- Versatile design can be mounted in any position.

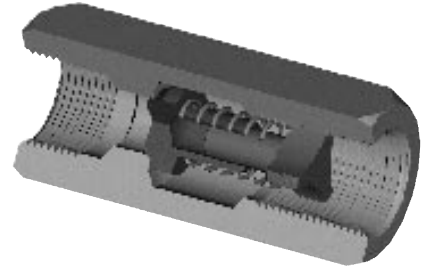

Ordering Information:

Part Number	Seating Option	Inlet/Outlet Connections FNPT P	Length L	Wrenching Hex Size D	Cv	Maximum Operating Pressure
Stainless Steel Check Valves						
C250SS	METAL	1/4"	2 3/8"	13/16"	.87	5000 PSIG
C375SS	METAL	3/8"	2 1/2"	1"	2.3	5000 PSIG
C500SS	METAL	1/2"	3"	1 1/8"	3.5	5000 PSIG
C750SS	METAL	3/4"	3 5/8"	1 1/2"	5.2	5000 PSIG
C250SSL	SOFT	1/4"	2 3/8"	13/16"	.87	250 PSIG
C375SSL	SOFT	3/8"	2 1/2"	1"	2.3	250 PSIG
C500SSL	SOFT	1/2"	3"	1 1/8"	3.5	3000 PSIG
C750SSL	SOFT	3/4"	3 5/8"	1 1/2"	5.2	3000 PSIG
Brass Body Check Valves						
C250B	METAL	1/4"	2 3/8"	13/16"	.87	3000 PSIG
C375B	METAL	3/8"	2 1/2"	1"	2.3	3000 PSIG
C500B	METAL	1/2"	3"	1 1/8"	3.5	3000 PSIG
C750B	METAL	3/4"	3 5/8"	1 1/2"	5.2	3000 PSIG
C250BL	SOFT	1/4"	2 3/8"	13/16"	.87	250 PSIG
C375BL	SOFT	3/8"	2 1/2"	1"	2.3	250 PSIG
C500BL	SOFT	1/2"	3"	1 1/8"	3.5	3000 PSIG
C750BL	SOFT	3/4"	3 5/8"	1 1/2"	5.2	3000 PSIG
Steel Check Valves						
C250S	METAL	1/4"	2 3/8"	13/16"	.87	5000 PSIG
C375S	METAL	3/8"	2 1/2"	1"	2.3	5000 PSIG
C500S	METAL	1/2"	3"	1 1/8"	3.5	5000 PSIG
C750S	METAL	3/4"	3 5/8"	1 1/2"	5.2	5000 PSIG
C250SL	SOFT	1/4"	2 3/8"	13/16"	.87	250 PSIG
C375SL	SOFT	3/8"	2 1/2"	1"	2.3	250 PSIG
C500SL	SOFT	1/2"	3"	1 1/8"	3.5	3000 PSIG
C750SL	SOFT	3/4"	3 5/8"	1 1/2"	5.2	3000 PSIG

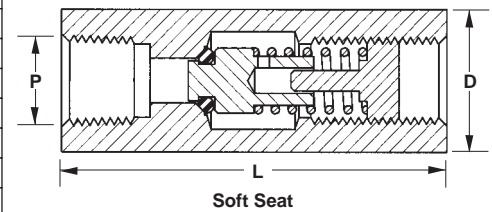
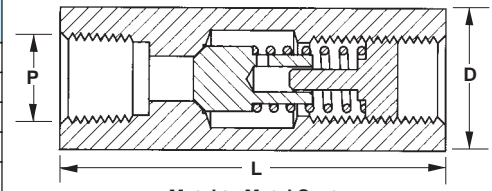

Specifications:

Maximum Operating Pressure	See Ordering Information
Temperature Range	-20°F to +212°F
CV Factor	See Ordering Information
Cracking Pressure	5 PSIG Standard, call for other settings

Materials:

Body	ASTM B 16 Brass, 12L14 Steel, or 303 Stainless Steel
Spring	Stainless Steel
Piston	Stainless Steel
Piston Seat - soft-	Viton

Performance

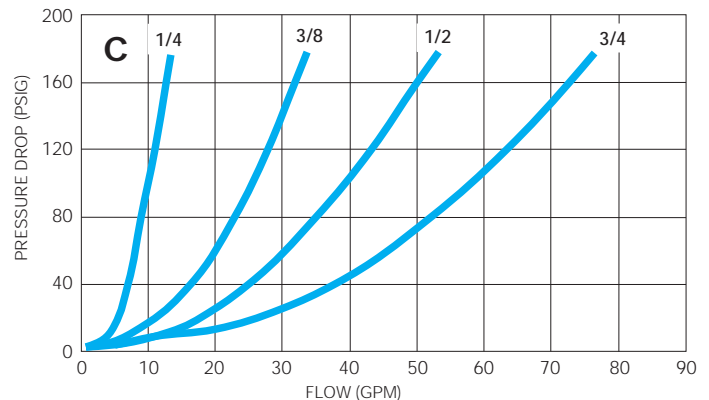

Check Valves

BC & PC Series

Compact, versatile design for the control of air and liquids.
Allows full-flow in one direction.

Features:

- Piston check design for leak-free air service.
- Ball check design for heavy duty liquid service.
- Low cracking pressures and smooth operation provide efficient service.
- Steel valves are zinc-plated and sealed with “golden glow” chromate for double corrosion protection.



Ordering Information:

Part Number	Body Material	Check Style	P (NPT) Female	D (In.) Hex	L (In.)	G (In.)	Orifice Diameter (In.)	CV	Cracking Pressure (PSIG)
PCI25B	Brass	Piston	1/8	1 1/16	1 1/2	9/32	.203	.21	10
PC250B			1/4	7/8	2	5/16			
PC375B			3/8	1 1/16	2 1/4	1 1/32			
PC500B			1/2	1 5/16	2 2 1/32	3/8			
BC125B	Brass	Ball	1/8	1 1/16	1 1/2	9/32	.203	.21	11
BC250B			1/4	7/8	2	5/16			
BC375B			3/8	1 1/16	2 1/4	1 1/32			
BC500B			1/2	1 5/16	2 2 1/32	3/8			
BC250S	Steel	Ball	1/4	7/8	2	5/16	.203	.45	7
BC375S			3/8	1 1/16	2 1/4	1 1/32			
BC500S			1/2	1 5/16	2 2 1/32	3/8			
BC750S			3/4	1 5/8	3	1 5/32			

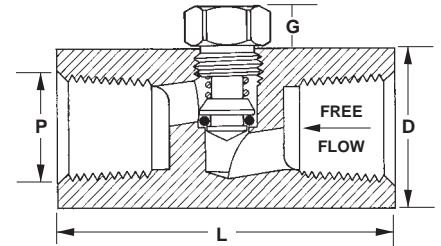
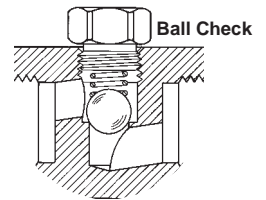

Specifications:

Maximum Operating Pressure	
“BC” Models	5000 PSIG Steel 2000 PSIG Brass
“PC” Models	2500 PSIG Steel 2000 PSIG Brass
Temperature Range	-20°F to +212°F
CV Factor	See Ordering Information

Materials:

Body	12L14 Steel or ASTM B16 Brass
Piston Assembly “PC” Models	Stainless Steel with Viton O-Ring
Ball, “BC” Models	Stainless Steel
Spring	Stainless Steel
Plug	Steel or Brass

Performance

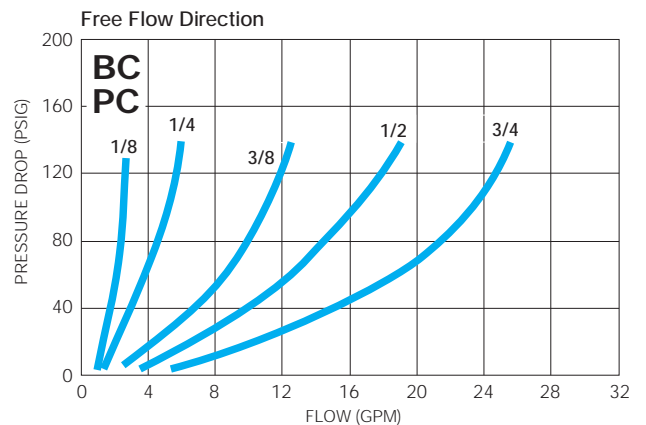

Check Valves

CMM Series

Space saving, in-line design for the control of air and liquids.

Features:

- Metal to Metal seal for leak-free liquid service.
- O-ring design for leak-free air service.
- Steel valves are zinc-plated and sealed with clear chromate for double corrosion protection.

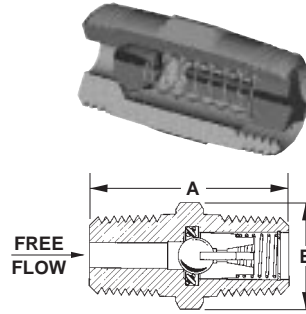

Specifications:

Maximum Operating Pressure	See Ordering Information
Temperature Range	-20°F to +400°F
Cracking Pressure	See Ordering Information
CV Factor	See Ordering Information

Ordering Information:

Part Number	Body Material	Seal	Port Size (NPT) Male	A (In.)	B (In.) Hex	Orifice Diameter (In.)	CV	Cracking Pressure (PSIG)	Maximum Pressure (PSIG)
CMM250B	Brass	Metal	1/4	1 5/32	9/16	3/16	.5	7	1000
CMM250B-L		Viton							
CMM375B		Metal							
CMM250S	Steel	Metal	1/4	1 5/32	9/16	3/16	.5	7	3000
CMM250S-L		Viton							
CMM375S		Metal							

Materials:

Body	ASTM B 16 Brass or 12L14 Steel
Ball	Stainless Steel
Retainer	Brass or Steel
Spring	Stainless Steel

8830E Excess Flow Check Series

Designed to automatically close when air flow exceeds a safe level. For use on all compressed air hoses leading to air tools and pneumatic components.

Features:

- Re-sets automatically.
- In-line design for easy installation.

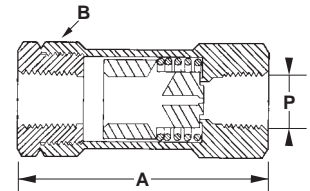
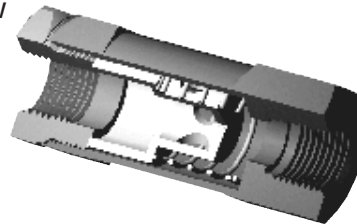

Operation:

During normal operation, a specially molded seal (A) is held away from its seat (B) by spring (C). Air flow is allowed to pass through the orifice (D). When a sudden surge of air flow occurs which exceeds the rated flow of the valve, the resulting pressure differential forces the spring to compress and the seal to contact its seat as in figure 2. After the cause of the higher air flow is repaired, air passing through orifice (E) slowly builds downstream pressure until the differential is low enough for the spring to return the seal to its normal position.

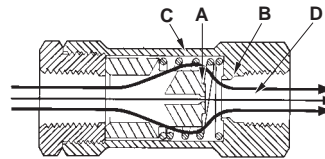

fig. 1 Normal flow condition

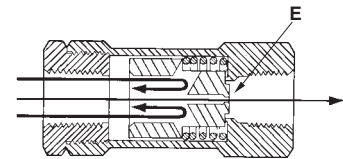

fig. 2 Shut-off condition

Specifications:

Maximum Operating Pressure	250 PSIG Air
Temperature Range	-40°F to +250°F

Materials:

Body	Aluminum
Seat	Delrin
Spring	Stainless Steel

Ordering Information:

Part Number	P (NPT) Female	A (In.)	B (In.) Hex	Approximate closing flow rate (Standard cubic feet per minute/air)							Pressure Drop to Close Valve @ 100 PSIG
				(Inlet Pressure PSIG)							
				25	50	90	125	150	200	250	
8830E3	3/8	3 1/2	1 3/8	29	38	48	56	60	69	76	1 1/2 to 3
8830E4	1/2			50	65	80	90	100	115	125	3 to 5
8830E6	3/4	5	2 1/4	140	175	200	260	280	320	360	1 1/2 to 4
8830E8	1			210	265	340	395	425	490	540	5 to 7

*To obtain closing flow rates at an inlet pressure, P, that is not shown above, use the following formula:

$$\text{Closing Flow} = \frac{\text{SCFM at 100 PSIG}}{(P + 14.7) / 104.7}$$

PRV - Series

Application

The PRV series of relief valves are ideal for air service. The valve will weep slightly at set pressure and achieve full lift and high flow by 110 percent of their rated set pressure.

Features

- Bubble tight at 95% of set pressure.
- Easy to read color coded psig / bar labels.
- Unique tamper resistant and staked adjusting screw.
- Repeatable performance.
- 100% factory tested.
- Temperatures Range -320 to +212 F.
- Set pressures range from 17-600psi.

Materials

BodyBrass
 Spring.....Stainless Steel
 Seat RetainerBrass
 Adjusting ScrewBrass
 Seat Disc (Below 140psi).....Fluorosilicone
 (Above 140psi).....Teflon

PRV Series also available with all stainless steel components.

Ordering Information

The PRV - series valves are ordered by specifying the basic relief valve part number and specifying with or without pull ring.

Example:

PRV	250B	R	350
Series	size	ring or no ring	pressure setting

This indicates a PRV250BR350 relief valve is a 1/4" valve with a pull ring set at 350.

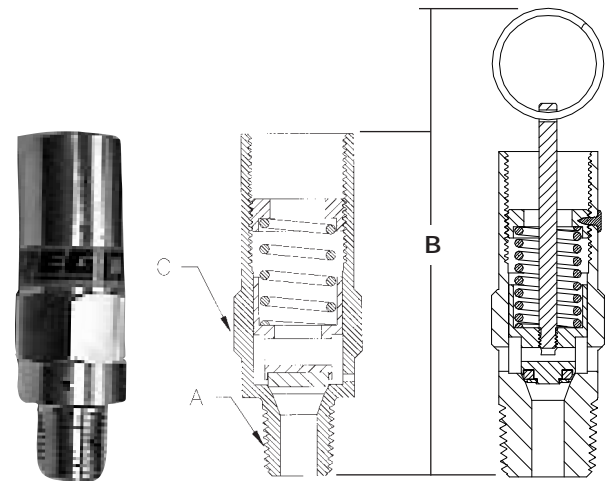

Ordering Information

Part Number Specify Relief Setting "XXX"	Pull Ring	Body	A (NPT) Male	B Ht.	C (In.) Hex	Relief Setting
PRV250BRXXX	Yes	Brass	1/4	3.0	7/8	Available in settings from 17-600 psi.
PRV250BXXX	No			2.6		
PRV500BRXXX	Yes		1/2	3.2		
PRV500BXXX	No			2.8		
SS 250TXXX	No	Stainless	1/4"	2.6		
SS 500TXXX	No	Steel	1/2"	2.8		

WARNING: Inspection and maintenance of pressure relief valves is very important. Failure to properly inspect and maintain pressure relief valves could result in personal injuries or property damage. The useful safe service life of a pressure relief valve may be significantly affected by the service environment.

Flow Data for Rego 1/4", 3/8" & 1/2" Relief Valves:

Set Pressure PSIG	Flow Pressure PSIG	Flow Rate SCFM Air
22	24	29
50	55	52
100	110	93
150	165	134
230	253	200
350	385	298
400	440	339
450	495	380
500	550	421

Pressure Compensated Valves

AFR Series

Provides accurate control of hydraulic actuator speeds and automatically compensates for changes in system pressure.

Features:

- Adjustable flow range.
- Easy-to-read micrometer knob for exact flow setting.
- All valves supplied with VITON seals.
- Free reverse-flow with low pressure drop.
- All valves are zinc-plated and sealed with black chromate for double corrosion protection.
- Set screw provided to secure valve setting.

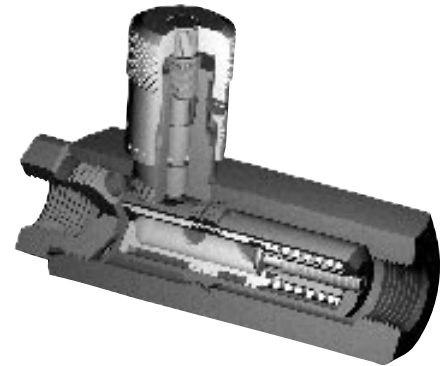

Ordering Information:

Part Number	P (NPT) Female	Flow Range GPM	D (In.) Square	L (In.)	E (In.) Max	Operating Pressure Range
AFR250	1/4"	0-4	1.25	3.70	1.35	500-3000
AFR375	3/8"	0-8	1.50	4.65	1.75	
AFR500	1/2"	2-18		5.00	2.00	200-3000

Specifications:

Operating Pressure Range	See Ordering Information
Temperature Range	-20°F to +350°F
Accuracy	± 10%
Stem Pitch	40 Threads/Inch

Materials:

Body	12L14 Leaded Steel
Piston	11L17 Leaded Steel
Stem	Stainless Steel — 1/4" & 3/8" Sizes 12L14 Leaded Steel — 1/2" Size
Spring	Steel
Knob	Aluminum
Set Screw	Steel
Seals	Nylon & Viton

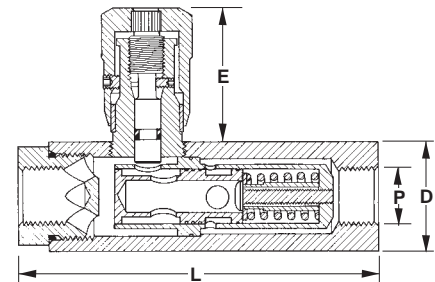

ARV SERIES

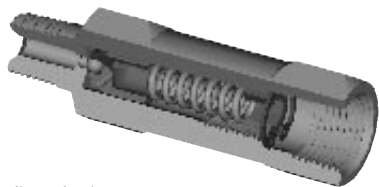

Features:

- Space saving in line design.
- Retaining ring prevents adjusting screw from being backed out too far.
- Pop-off action does not “chatter” or “scream”.
- Metal-to-metal seal assures long life.
- Suitable for oil, water and steam.

Specifications:

Operating Range	400 to 5000 PSIG
Temperature Range	-60°F to +450°F
CV Factor	.21
Orifice Diameter	$\frac{3}{32}$ "

Ordering Information:

Part Number	A (NPT) Inlet Port	B (NPT) Outlet Port	C (In.) Length	D (In.) Hex
ARV250B	$\frac{1}{4}$ " Male	$\frac{3}{8}$ " Female	$3\frac{1}{8}$	$\frac{7}{8}$

Adjustable design to relieve liquid pressure above a predetermined setting. For use anywhere excessive pressure may harm system components.

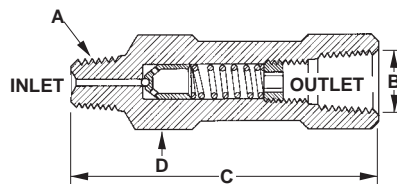

Materials:

Body	ASTM B16 Brass
Spring	303 Stainless Steel
Piston	Brass
Ball	Stainless Steel
Adjusting Screw	302 Stainless Steel ($\frac{1}{4}$ " Allen Wrench)
Retaining Ring	Stainless Steel

Flow Data

Flow and pressure drop characteristics for valves manufactured by Engineered Controls International, Inc. are based on laboratory testing of random production samples and by an independent testing agency. The graphs are based on 150 SSU oil at the controlled temperature of 140°F.

Flow coefficients (C_V) have been provided for valves in this catalog. Calculating flow or pressure drop at other conditions is achieved with the following equation:

$$\text{Flow in GPM} = \frac{C_V \sqrt{P_1 - P_2}}{\sqrt{G_f}}$$

Where...

- C_V = Flow coefficient
- P_1 = Inlet pressure (PSIG)
- P_2 = Outlet pressure (PSIG)
- G_f = Specific gravity of medium at operating temperature

Warranty and Liability

Canadian Registration Numbers

The majority of products in this catalog are registered with the Canadian Department of Labor under the following reference numbers:

Province	CRN	Province	CRN
1 British Columbia	0 * 1741.51	8 Nova Scotia	(A) 07504.8 (C) 07505.8
2 Alberta	0 * 1714.5T		(D) 07506.8 (F) 07507.8
3 Saskatchewan	0 * 1741.53		(G) 07508.8 (H) 07509.8
4 Manitoba	0 * 1741.54	9 Prince Edward Island	Applied for
5 Ontario	0 * 1741.5	0 Newfoundland	0 * 1741.50
6 Quebec	0 * 1741.56	T Northwest Territories	0 * 1741.5T
7 New Brunswick	0 * 1741.57	Y Yukon Territory	0 * 1741.5Y

* Represents Fitting Categories A, C, D, F, G, H

Limited Warranty and Limitation of Liability

LIMITED WARRANTY

Engineered Controls International, Inc. warrants products and repair kits manufactured by it to be free from defects in materials and workmanship under normal use and service for a period of 12 months from the date of installation or operation or 18 months from the date of shipment from the factory, whichever is earlier. If within thirty days after buyer's discovery of what buyer believes is a defect, buyer notifies Engineered Controls International, Inc. thereof in writing, Engineered Controls International, Inc., at its option, and within forty-five days, will repair, replace F.O.B. point of manufacture, or refund the purchase price of that part or product found by it to be defective. Failure of buyer to give such written notice within thirty days shall be deemed an absolute and unconditional waiver of any and all claims of buyer arising out of such defect.

This warranty does not extend to any product or part that is not installed and used in accordance with Engineered Controls International, Inc.'s printed instructions, all applicable state and local regulations, and all applicable national standards, such as those promulgated by NFPA, DOT and ANSI. This warranty does not extend to any product or part that has been damaged by accident, misuse, abuse or neglect, nor does it extend to any product or part which has been modified, altered, or repaired in the field.

Except as expressly set forth above, and subject to the limitation of liability below, Engineered Controls International, Inc. makes NO OTHER WARRANTY, EXPRESS OR IMPLIED, INCLUDING, BUT NOT LIMITED TO THE IMPLIED WARRANTIES OF MERCHANTABILITY AND FITNESS FOR A PARTICULAR PURPOSE, with respect to its products and parts, whether used alone or in combination with others. Engineered Controls International, Inc. disclaims all warranties not stated herein.

LIMITATION OF LIABILITY

Engineered Controls International, Inc.'s total liability for any and all losses and damages arising out of any cause whatsoever shall in no event exceed the purchase price of the products or parts in respect of which such cause arises, whether such cause be based on theories of contract, negligence, strict liability, tort or otherwise.

Engineered Controls International, Inc. shall not be liable for incidental, consequential or punitive damages or other losses. Engineered Controls International, Inc. shall not be liable for, and buyer assumes liability for, all personal injury and property damage connected with the handling, transportation, possession, further manufacture, other use or resale of products, whether used alone or in combination with any other products or material.

If Engineered Controls International, Inc. furnishes technical advice to buyer, whether or not at buyer's request, with respect to application, further manufacture or other use of the products and parts, Engineered Controls International, Inc. shall not be liable for such technical advice and buyer assumes all risks of such advice and the results thereof.

NOTE: Some states do not allow the limitation or exclusion of incidental or consequential damages, so the above limitations or exclusions, wholly or partially, may not apply. The portions of this limited warranty and limitation of liability shall be considered severable and all portions which are not disallowed by applicable law shall remain in full force and effect.

WARNING

All Engineered Controls International, Inc. products are mechanical devices that will eventually become inoperative due to wear, corrosion and aging of components made of materials such as rubber, etc. The environment and conditions of use will determine the safe service life of these products. Periodic inspection and maintenance are essential to avoid serious injury and property damage.

Many Engineered Controls International, Inc. products are manufactured components which are incorporated by others on or in other products or systems used for storage, transport, transfer and otherwise for use of toxic, flammable and dangerous liquids and gases. Such substances must be handled by experienced and trained personnel only, using accepted governmental and industrial safety procedures.

NOTICE TO USERS OF PRODUCTS

The Limited Warranty stated above is a factory warranty to the first purchasers of Engineered Controls International, Inc. products. Since most users have purchased these products from Engineered Controls International, Inc. distributors, the user must within thirty (30) days after the user's discovery of what user believes is a defect, notify in writing the distributor from whom he purchased the product/parts. The distributor may or may not at the distributor's option, choose to submit the product/parts to Engineered Controls International, Inc. pursuant to its Limited Warranty. Failure by buyer to give such written notice within thirty (30) days shall be deemed an absolute and unconditional waiver of buyer's claim for such defects. Acceptance of any alleged defective product/parts by Engineered Controls International, Inc.'s distributor for replacement or repairs under the terms of Engineered Controls International, Inc.'s Limited Warranty in no way obligates Engineered Controls International, Inc. to the terms of the above warranty.

Because of a policy of continuous product improvement, Engineered Controls International, Inc. reserves the right to change designs, materials or specifications without notice.

Compact Pneumatic Flow Controls With Push-In-Tube Connection

Features:

- Compact design permits mounting directly on pneumatic cylinder.
- Push-In-Tube connections allow convenient tube assembly without the need for tools or other components.
- Tubing easily installed by pushing into outlet and released by pressing collet and pulling.
- Available with convenient knurled knob or tamper resistant recessed screwdriver slot.
- Valves are nickel plated for corrosion protection.
- Unique cup seal provides positive seal during metered flow.
- Precision long-tapered stem provides accurate control.
- Tube Port rotates fully after mounting.

Specifications:

Operating Pressure 15 to 150 PSIG
 Temperature Range +32° F to +176° F
 Body Material OT58 Brass Body with Nickel Plating
 Seal Material Buna-N

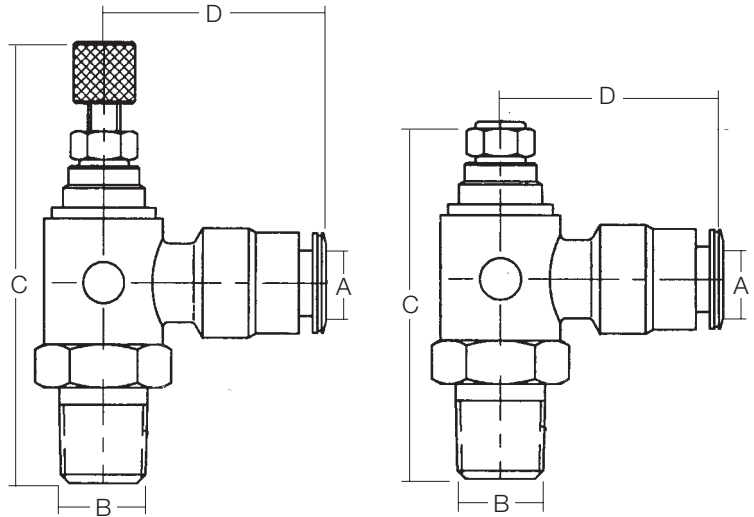

Ordering Information:

Part Number	Actuation	A Tube Port O.D.	B Mounting Port	C Height (Valve Open)	D
RAM 53-02	Knurled Knob	5/32"	1/8" NPT	1 1/8"	7/8"
RAM 4-02		1/4"	1/4" NPT	2 1/4"	1 1/16"
RAM 6-04		3/8"	3/8" NPT	2 5/8"	1 1/8"
RAM 6-06		1/2"	1/2" NPT	3 1/8"	1 1/16"
RAS 53-02	Recessed Screwdriver Slot	5/32"	1/8" NPT	1 1/2"	7/8"
RAS 4-02		1/4"	1/4" NPT	1 5/8"	1 1/16"
RAS 6-04		3/8"	3/8" NPT	1 7/8"	1 1/8"
RAS 6-06		1/2"	1/2" NPT	2 1/4"	1 1/16"

Performance

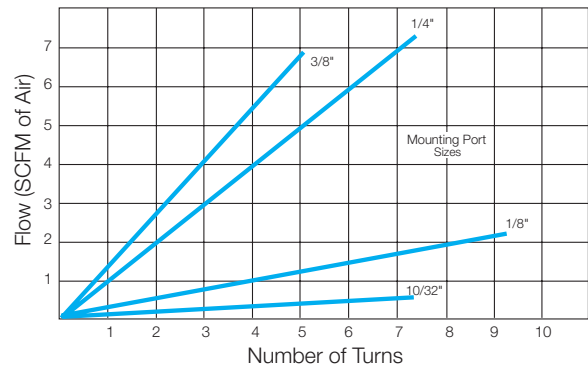

CW-series check valves

- A check valve specifically designed and manufactured for the car wash/pressure washing industry.
- Unique two piece construction allows the user to dis-assemble the valve, clean and replace seals as necessary.
- Both valves which are available in 1/4" and 3/8"NPTF contain O-rings of Viton7 and Buna-N for long-lasting durability.
- Maximum operating pressure on each valve is 200 psi.
- Cracking pressure is 5 psig.

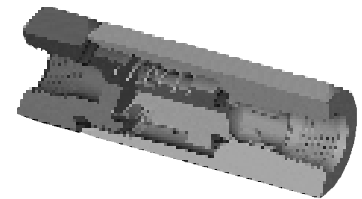

Valve Number	Material	Thread (Both Ends)	A - Length (in)	B - Width (in)
CW250BL	ASTM B 16 Brass	1/4 NPTF	3.03	1.00
CW375BL	ASTM B 16 Brass	3/8 NPTF	3.03	1.00
CW250SSL	303 Stainless Steel	1/4 NPTF	3.03	1.00
CW375SSL	303 Stainless Steel	3/8 NPTF	3.03	1.00

REGO CRYO-FLOW PRODUCTS

Phone: (336) 226-3244
 Fax: (336) 227-6294
 E-mail: cfo@regoproducts.com

Division of Engineered Controls International, Inc.

REGO CRYO-FLOW
PRODUCTS

3181 Lear Drive Burlington, NC 27215 USA Phone (336) 226-3244 Fax (336) 227-6294
www.regoproducts.com/cryoflow Catalog 201C Printed In U.S.A. 04-0397-500