

➤ Electric Motor Pumps

- Quiet operation meets OSHA regulations (80dBA)
- 2 speed operation allows for faster cylinder advance
- Full load starting capacities
- Internal filter keeps contamination from damaging pump
- Rugged durable design meets the demands of industrial applications
- Precision components to minimize wear and improve overall dependability
- Designed to minimize the number of moving parts and maximize overall pump efficiency
- Available in 3-way or 4-way configuration
- Ideal for on site construction as well as maintenance

Cylinder Accessories

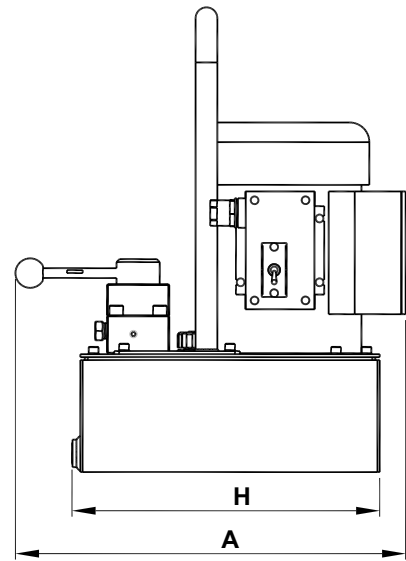
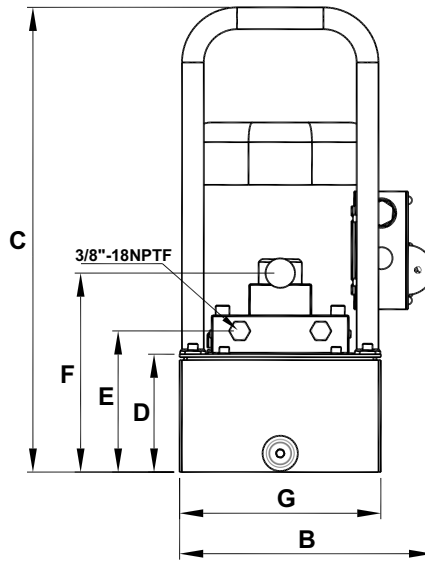
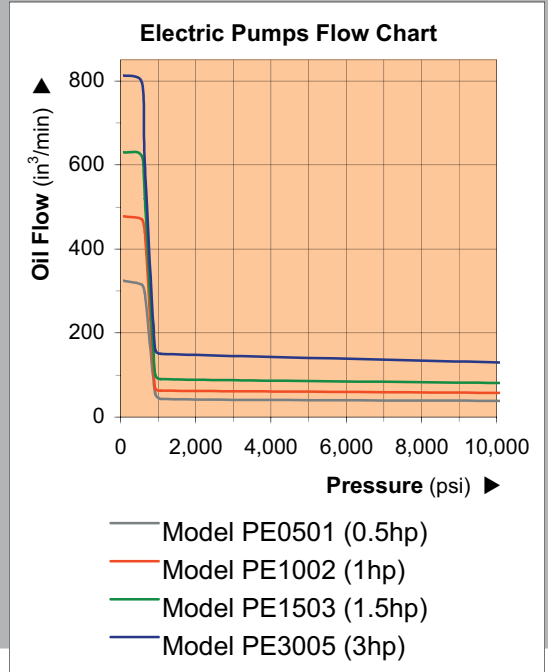
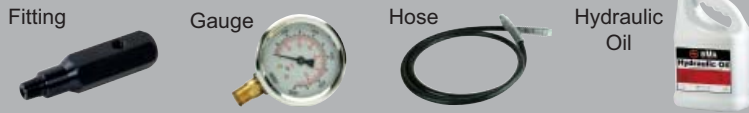

Motor Size (hp)	Usable Oil Cap. (gal)	Model Number	Model with Pendant Switch	Pressure Rating (psi)		Oil Output Flow Rate (in ³)		Valve Type	Valve Function	Current Draw (amps)	Motor Voltage (volts)	Sound Level (dBA)	W.t. for PE (lbs)	W.t. for PEW (lbs)
				1st Stage	2nd Stage	1st Stage	2nd Stage							
0.50	1.00	PE0501	PEW0501	580	10,000	305	18	Manual	4-way, 3-position	8	115	80	48.0	50.0
1.00	2.00	PE1002	PEW1002			458	37			15			60.0	62.0
1.50	3.00	PE1503*	PEW1503			610	61			17			75.0	77.0
3.00	5.00	PE3005	PEW3005			793	110			15			108.0	110.0

* 5 gal reservoir is available for this model



• E-pump is compatible with a wide variety of industrial applications



PE1002



PEW1503



PE3005



• PEW01 Pendant Switch

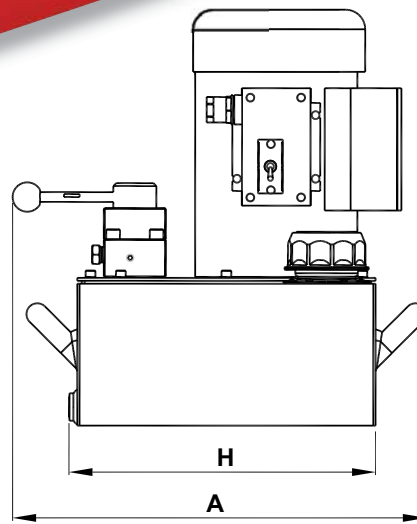
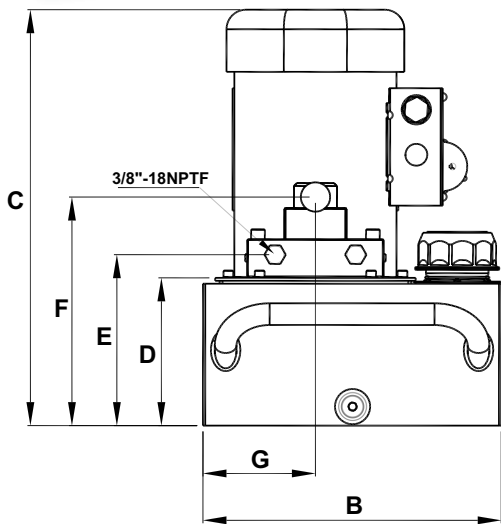

Model Number	Dimensions (in)							
	A	B	C	D	E	F	G	H
PE0501	15.67	10.16	18.62	4.72	5.67	7.99	8.07	12.36
PE1002	16.65	12.01	16.73	5.94	6.89	9.21	4.53	12.36
PE1503	16.65	12.01	19.02	7.24	8.19	10.51	4.53	12.36
PE3005	16.65	12.01	24.65	12.48	13.43	15.75	4.53	12.36